

Honeywell

INSTALLATION MANUAL

BENDIX/KING[®]

KT 76C

***ATCRBS
TRANSPONDER***

MANUAL NUMBER 006-10545-0003

Revision 3, May 2004

WARNING

THE ENCLOSED TECHNICAL DATA IS ELIGIBLE FOR EXPORT UNDER LICENSE DESIGNATION NLR AND IS TO BE USED SOLELY BY THE INDIVIDUAL/ ORGANIZATION TO WHOM IT IS ADDRESSED. DIVERSION CONTRARY TO U.S. LAW IS PROHIBITED.

COPYRIGHT NOTICE

©1999, 2004 HONEYWELL INTERNATIONAL INC.

REPRODUCTION OF THIS PUBLICATION OR ANY PORTION THEREOF BY ANY MEANS WITHOUT THE EXPRESS WRITTEN PERMISSION OF HONEYWELL IS PROHIBITED. FOR FURTHER INFORMATION CONTACT THE MANAGER, TECHNICAL PUBLICATIONS, HONEYWELL, ONE TECHNOLOGY CENTER, 23500 WEST 105TH STREET OLATHE KS 66061 TELEPHONE: (913) 782-0400.

REVISION HISTORYINSTALLATION MANUAL
BENDIX/KING
KT 76C ATCRBS Transponder

PART NUMBER	REV	DATE	DESCRIPTION
006-10545-0003	3	May/2004	Referenced drawing for dimensions and weight.
006-10545-0002	2	May/2004	Added version -0201
006-10545-0001	1	Dec/1999	

THIS PAGE RESERVED BLANK

**SECTION I
GENERAL INFORMATION**

Paragraph	Page
1.1 INTRODUCTION	1-1
1.2 EQUIPMENT DESCRIPTION	1-1
1.3 TECHNICAL CHARACTERISTICS	1-2
1.3.1 KT 76C PHYSICAL CHARACTERISTICS	1-2
1.3.2 KA 60 PHYSICAL CHARACTERISTICS	1-6
1.4 UNITS AND ACCESSORIES SUPPLIED	1-6
1.4.1 CONFIGURATIONS AVAILABLE	1-6
1.4.2 KT 76C INSTALLATION KIT	1-7
1.5 ACCESSORIES REQUIRED, BUT NOT SUPPLIED.	1-8
1.6 LICENSE REQUIREMENTS	1-9
1.7 INSTRUCTIONS FOR CONTINUED AIRWORTHINESS	1-9

**SECTION II
INSTALLATION**

Paragraph	Page
2.1 GENERAL INFORMATION	2-1
2.2 UNPACKING AND INSPECTING EQUIPMENT	2-1
2.3 EQUIPMENT INSTALLATION	2-1
2.3.1 GENERAL	2-1
2.3.2 AVIONICS COOLING REQUIREMENTS FOR PANEL MOUNTED EQUIPMENT	2-1
2.3.3 KT 76C INTERCONNECT WIRING AND CABLE HARNESS FABRICATION	2-2
2.3.4 EQUIPMENT LOCATION	2-3
2.3.5 KT 76C INSTALLATION	2-4
2.3.6 VOLTAGE CHANGE OVER INSTRUCTIONS	2-5
2.3.7 KT76A/KT78A TO KT 76C CHANGE OVER INSTRUCTIONS.	2-5
2.3.8 MOLEX CONNECTOR ASSEMBLY PROCEDURE	2-6
2.4 POST INSTALLATION TEST PROCEDURE.	2-14
2.4.1 TRANSPONDER SYSTEM CHECKOUT.	2-14

**SECTION III
OPERATION**

Paragraph	Page
3.1 GENERAL	3-1
3.2 DETAILED OPERATING MODES	3-1
3.2.1 FUNCTIONAL MODES	3-1

3.2.2	FRONT PANEL OPERATION	3-3
-------	-----------------------------	-----

TSO APPENDIX E

	ENVIRONMENTAL QUALIFICATION FORM	E-1
--	--	-----

LIST OF ILLUSTRATIONS

Figure		Page
2-1	CRIMPING TOOL	2-7
2-2	KT 76C INTERCONNECT DIAGRAM	2-10
2-3	KT 76C TRANSPONDER INSTALLATION DRAWING	2-19
2-4	KA 60 ANTENNA INSTALLATION DRAWING	2-21
2-5	ACCEPTABLE CABLE CONNECTIONS DRAWING.....	2-22
2-6	CABLE CONNECTOR DRAWING.....	2-24
2-7	KT 76C RF CONNECTOR ASSEMBLY DRAWING	2-25
2-8	TYPE "N" AND "C" CONNECTOR ASSEMBLY DRAWING	2-27
2-9	BNC CONNECTOR CABLE ASSEMBLY DRAWING	2-28
3-1	UNIT FUNCTIONS.....	3-1
3-2	STANDBY	3-2
3-3	TEST	3-2
3-4	UNIT ON	3-3
3-5	ALTITUDE	3-3
3-6	IDENT	3-4
3-7	VFR	3-5
3-8	ALTITUDE DISPLAY	3-6

LIST OF TABLES

Table		Page
1-1	KT 76C TECHNICAL CHARACTERISTICS.....	1-2
1-2	KA 60 TECHNICAL CHARACTERISTICS.....	1-6
1-3	KT 76C CONFIGURATIONS AVAILABLE.....	1-6
1-4	KT 76C INSTALLATION KIT	1-7
1-5	CABLE SETUP 4.5 to 11 FEET	1-8
1-6	CABLE SETUP 10 to 25 FEET	1-8
1-7	CABLE SETUP 16 to 32 FEET	1-8
2-1	INSPECTION/CHECK PROCEDURE	2-14
2-2	RAMP TESTS	2-17

SECTION I GENERAL

1.1 INTRODUCTION

This manual contains information relative to the physical, mechanical, and electrical characteristics of the Honeywell Silver Crown KT 76C ATCRBS Transponder. Installation and operating procedures are also included. Information relative to the maintenance, alignment, and procurement of the replacement parts may be found in the KT 76C Maintenance/Overhaul Manual, P/N 006-15545-00XX (XX = latest revision available).

1.2 EQUIPMENT DESCRIPTION

The KT 76C is a panel mounted, TSO certified Transponder designed to fulfill the role of the airborne beacon equipment according to the requirements of the Air Traffic Radar Beacon System (ATCRBS) that include ATCRBS Mode A, and ATCRBS Mode C.

The KT 76C features a microprocessor controlled gas discharge display. The 4096 identification code selection is entered with push-button switches. A rotary knob is used for mode selection control. Additional push-button switches including IDT, VFR, and CLR are provided.

When the KT 76C receives Mode A interrogations from the ground radar facility, it will transmit a coded group of pulses which consist of a four digit identification number that has been assigned by the Air Traffic Controller. This code is entered into the KT 76C by the pilot and is transmitted back to the ground as a Mode "A" reply. This coded information is presented on the ground radar display at the appropriate range and azimuth. The Air Traffic Controller can then identify each aircraft that is transponder equipped by its distinct coded number.

The VFR code and display brightness can be programmed from the front panel of the KT 76C and stored in nonvolatile memory, this programming sequence is described in Section III.

The KT 76C also provides Mode "C" or altitude reporting information. When the KT 76C is operated in the "ALT" Mode and used in conjunction with an encoding altimeter, the flight level altitude is displayed in addition to the transponder code, and the altitude information is transmitted to the ground in response to Mode "C" interrogations.

When the "IDT" button is pressed, the current 4096 code and an additional special ident pulse are transmitted by the KT 76C, to insure positive identification.

A test mode is also included in the KT 76C to confirm that all segments in the display are operational.

1.3 TECHNICAL CHARACTERISTICS

1.3.1 KT 76C PHYSICAL CHARACTERISTICS

Table 1-1 KT 76C Technical Characteristics

TSO Compliance:	C74c Class 1A Environmental - See TSO Appendix Software - Criticality Level "D"
Physical Dimensions:	See Figure 2-3, Dwg No. 155-06039-0000.
Weight:	See Figure 2-3, Dwg No. 155-06039-0000.
Applicable Documents:	TSO-C74c (Technical Standard Order ATC Transponder Equipment) RTCA DO-160C (Environmental Conditions and Test Procedures) RTCA DO-178B (Software Considerations in Airborne Systems)
Mounting:	Panel Mounted
Temperature:	-20 °C to +55 °C
Altitude:	35,000 feet
Cooling:	No forced air cooling required, but recommended.
Vibration:	Constant total excursion of 0.2 in. from 5 to 17 Hz From 17 to 38 Hz - 3.0 g-pk From 38 to 500 Hz - 1.5 g-pk From 500 to 2000 Hz - 1.0 g-pk
Shock:	Rigid mounting 6 G operational 15 G crash safety.
Power Input:	Watts maximum 0.7 Amperes @ 27.50 Vdc 1.6 Amperes @ 13.75 Vdc Standby current: 0.400 A @ 28 Vdc 0.758 A @ 14 Vdc Lighting current: 55 +/- 17 mA @ 28 Vdc 110 +/- 34 mA @ 14 Vdc
Receiver Characteristics:	
Sensitivity Variation with Frequency:	The RF input level required to produce 90% replies will not vary by more than 1 dB between modes and will at no time exceed a level of -69 dBm for standard ATCRBS interrogations in the frequency range between 1029.8 and 1030.2 MHz.
Bandwidth:	A standard ATCRBS interrogation signal below 1005 MHz and above 1055 MHz will be at least 60 dB stronger than that required to produce the same reply efficiency at 1030 MHz.

Table 1-1 KT 76C Technical Characteristics

Sensitivity and Dynamic Range:	The minimum triggering level (MTL) is defined as the minimum input power level that results in a 90% reply ratio if the interrogation has nominal pulse characteristics.
	A. The MTL for ATCRBS will be -73 dBm +/- 4 dB.
	B. The reply ratio will be at least 90% for ATCRBS interrogations between MTL and 50 dB above MTL.
	C. The variation of MTL between ATCRBS Mode A and Mode C interrogations will not exceed 1 dB.
Transmitter Characteristics:	
Reply Transmission Frequency:	The transmitter frequency of the reply will be 1090+/- 3MHz when observed in a 50Ω load with a VSWR of 1.2:1 or less.
RF Peak Power Output:	The transmitter output power will be 125 watts peak power minimum and 500 watts peak power maximum at the terminals of the transponder antenna. The pulse amplitude variation between any two pulses in an ATCRBS reply will not exceed 1 dB.
ATCRBS Reply Rate Capability:	The transponder will be able to continuously generate at least 500 ATCRBS 15-pulse replies per second and will have the capability of a peak reply rate of 1,200 ATCRBS 15-pulse replies. NOTE: A 15-pulse reply includes 2 framing pulses, the 12 information pulses, and the SPI pulse.
Reply Pulse Characteristics:	
ATCRBS Reply Pulse Positions	The reply function will consist of two framing pulses and 13 information pulses. The pulse spacing tolerance for each pulse (including the last framing pulse) with respect to the first framing pulse of the reply group will be +/- 0.10 μsec. The pulse spacing tolerance of any pulse in the reply group with respect to any other pulse (except the first framing pulse) will be no more than +/- 0.15 μsec.

Table 1-1 KT 76C Technical Characteristics

<p>ATCRBS Reply Pulse position from the first framing pulse are as follows:</p>	<p><u>PULSE POSITION</u> (μsec)</p> <p>F1 0.00 (Reference) C1 1.45 A1 2.90 C2 4.35 A2 5.8 C4 7.25 A4 8.70 B1 11.60 D1 13.05 B2 14.50 D2 15.95 B4 17.40 D4 18.85 F2 20.30 SPI..... 24.65</p>
<p>ATCRBS SPI Reply Pulse:</p>	<p>Upon activation of the IDENT switch, the SPI pulse will be transmitted when replying to ATCRBS Mode A interrogations for a period of 18 +/- 2 seconds. The pulse spacing tolerance of the SPI pulse with respect to the last framing pulse will be +/- 0.10 μsec. The SPI pulse will not be transmitted when replying to Mode C interrogations.</p>
<p>ATCRBS Reply Pulse Shape:</p>	<p>All reply pulses and SPI pulses will be 0.45 μsec +/- 0.10 μsec duration and have rise times of 0.05 μsec through 0.1 μsec and decay times of 0.05 μsec through 0.2 μsec.</p>
<p>ATCRBS Reply Delay and Jitter:</p>	<p>A. At all RF input levels from MTL to 50 dB above MTL, the time delay from the leading edge of P3 to the leading edge of F1 (the first pulse of the reply) will be 3.0 +/- 0.5 μsec.</p> <p>B. At all RF levels from MTL + 3 to 50 dB above MTL the time delay variations between ATCRBS modes will not exceed 0.2 μsec.</p> <p>C. At all RF input levels from MTL + 3 dB to 50 dB above MTL the jitter at the leading edge of the first pulse of the reply with respect to P3 will not exceed +/- 0.10 μsec.</p>
<p>Suppression I/O</p>	<p>This pin is both an input and an output. The transponder will be suppressed if the input is +18 V dc to +70 V dc. While the transponder is transmitting it will drive this pin above 18 V dc. As an output, 18 volts will be maintained into a load of 300 ohms and 1850 pF.</p>
<p>Suppression In</p>	<p>The transponder will be suppressed if the voltage applied to this pin is above 6 V dc. This pin follows an Honeywell standard.</p>

Table 1-1 KT 76C Technical Characteristics

Side Lobe Suppression Characteristics:	
SLS Decoding and Dynamic Range:	A. When the RF input signal is varied from MTL +3 dB to 50 dB above MTL and the level of P2 equals or exceeds the level of P1 spaced 2.0 +/- 0.15 μ sec from P1 the transponder will reply to no more than 1% of the interrogations.
	B. When the RF input signal is varied from MTL +3 dB to 50 dB above MTL and the level of P1 exceeds the level of P2 by 9 dB or more, or P2 =P1 and is spaced 1.3 μ sec or 2.7 μ sec from P1, the transponder will reply to at least 90% of the interrogations.
Pulse Decoder Characteristics:	Unless otherwise specified, the following pulse decoder characteristics will apply for an RF input signal levels of MTL to 50 dB above MTL and nominal interrogation signal characteristics. Applicable "valid" interrogations will result in at least 90% replies, and interrogations which are "invalid" will result in less than 10% replies.
Pulse Position Tolerances:	A. The transponder <u>will accept</u> the pulse position of ATCRBS interrogations as valid if the spacing between P1 and P3 is within +/- 0.2 μ sec of the nominal spacing.
	B. The transponder <u>will not accept</u> the pulse position of ATCRBS as valid if the spacing between P1 and P3 differs from the nominal spacing by 1.0 μ sec or more.
Pulse Duration Tolerances:	The transponder <u>will accept</u> the pulses of an ATCRBS interrogation as valid if the duration of both P1 and P3 is between 0.7 and 0.9 μ sec.
NOTE: All measurements are made with a 2 dB cable loss.	

1.3.2 KA 60 PHYSICAL CHARACTERISTICS

Table 1-2 KA 60 Technical Characteristics

TSO Compliance:		TSO C66a (DME) TSO C74c (Transponder) DO-160 Environmental Categories: D2A/JY/XXXXXXXXXXXX
Physical Dimensions:	Height:	3.13 ± 0.2 inches (79.502 ± 5.08 mm)
	Width:	0.95 ± 0.2 inches (24.13 ± 5.08 mm)
	Length:	4.05 ± 0.2 inches (102.87 ± 5.08 mm)
	Weight:	0.20 lbs (0.09 kg)
Temperature:		-55 °C to +71 °C
Altitude:		55,000 feet
Vibration:		0.2 inch/ 2g - 0.02 inch /5g
Shock:		Rigid mounting 6 G operational 15 G crash safety.

1.4 UNITS AND ACCESSORIES SUPPLIED

1.4.1 CONFIGURATIONS AVAILABLE

Table 1-3 lists the available configurations of the transponder and the features contained in each configuration.

Table 1-3 KT 76C Configurations Available

HONEYWELL PART NUMBER	SUPPLY VOLTAGE	LAMP VOLTAGE	MOUNTING RACK	CIRCULATOR BOARD
066-01156-0101	11 - 33 Vdc	14 or 28 Vdc	047-09628-0004	200-09478-0010
066-01156-0201	11 - 33 Vdc	14 or 28 Vdc	047-09628-0004	200-09478-0020

1.4.2 KT 76C INSTALLATION KIT

The KT 76C Transponder installation kit contains the following parts:

Table 1-4 KT 76C Installation Kit P/N 050-01577-0001, Rev 14

PART NUMBER	DESCRIPTION	UM	QTY	VENDOR NAME & PART NUMBER
006-01058-0005	RF CONN ASSY INST	EA	1	Honeywell
030-00005-0000	CONN BNC CA RG142	EA	1	Ted Manufacturing 4-10-4
030-00101-0002	PANEL MOUNT PLUG	EA	1	Ted Manufacturing 9-30-10
030-01094-0002	CONNECTOR 12/24 P	EA	1	Honeywell
030-01096-0000	KEY POLARIZER	EA	1	Honeywell
030-01107-0024	CONNECTOR TERM 24T	EA	1	Honeywell
089-02013-0037	NUT HEX 6-32	EA	1	Honeywell
089-02353-0001	NUT CLIP 6-32	EA	6	Honeywell
089-05903-0007	SCR PHP 4-40 X 7/16	EA	2	Honeywell
089-05907-0006	SCR PHP 6-32 X 3/8	EA	1	Honeywell
089-06012-0008	SCR PHP 6-32 X 1/2	EA	6	Honeywell
089 08027-0030	WSHR FLT STD #6	EA	1	Honeywell
089-08094-0030	WSHR FLT STD .446	EA	1	Honeywell
089-08110-0034	WSHR SPLT LK #6	EA	1	Honeywell
089-08168-0002	WASHER WAVE	EA	1	Honeywell
090-00019-0007	RING RTNR .438	EA	1	Honeywell
091-00031-0005	NY CA CLAMP .312	EA	1	Richco N-5

1.5 ACCESSORIES REQUIRED, BUT NOT SUPPLIED

The following parts are recommended for a cable setup with dimensions of 4.5 feet to 11 feet: (See Figure 2-5, **Sheet 1 of 2**).

Table 1-5 Cable Setup 4.5 to 11 Feet

HONEYWELL PART NUMBER	DESCRIPTION	QUANTITY
006-01058-0005	Connector Assy Procedure	1
024-00051-0060	Cable, Coax	11 ft.
030-00092-0000	Connector, Coax Mod Type BNC	1
030-00101-0002	Connector, Coax	1

The following parts are recommended for a cable setup with dimensions of 10 feet to 25 feet: (See Figure 2-5, **Sheet 2 of 2**).

Table 1-6 Cable Setup 10 to 25 Feet

HONEYWELL PART NUMBER	DESCRIPTION	QUANTITY
006-01058-0005	Connector Assy Procedure	1
024-00072-0000	Cable, Coax	25 ft.
030-00102-0001	Connector, Type Unit	1
030-00435-0000	Connector, Antenna	1

The following parts are recommended for a cable setup with dimensions of 16 feet to 32 feet: (See Figure 2-5, **Sheet 2 of 2**).

Table 1-7 Cable Setup 16 to 32 Feet

HONEYWELL PART NUMBER	DESCRIPTION	QUANTITY
006-01058-0005	Connector Assy Procedure	1
024-00051-0060	Cable, Coax	6 in.
024-00071-0000	Cable, Coax	32.5 ft.
030-00101-0002	Connector Type Unit	1
030-00138-0000	Cable, Unit extension to antenna connector	1
030-00434-0000	Connector, Antenna	2

1.6 LICENSE REQUIREMENTS

The transmitter, as installed in the aircraft, requires an Aircraft Radio Station License. This license is obtained by filing the FCC Form 404. While awaiting the receipt of the station license, a copy of FCC Form 404 is kept in the aircraft.

This equipment has been type accepted by the FCC and entered on the type accepted equipment list, as Honeywell KT 76C and must be identified as Honeywell KT 76C on your Form 404, Aircraft Radio Station License application.

1.7 INSTRUCTIONS FOR CONTINUED AIRWORTHINESS

The instructions for continued airworthiness given in the TC or STC approvals for this product supplements or supersedes the instructions for continued airworthiness in this manual.

Most Honeywell products are designed and manufactured to allow "on condition maintenance". On condition maintenance is described as follows; There are no periodic service requirements necessary to maintain continued airworthiness. No maintenance is required until the equipment does not properly perform its intended function. When service is required, a complete performance test should be accomplished following any repair action. Consult the appropriate unit Maintenance/Overhaul Manual for complete performance test information.

THIS PAGE RESERVED BLANK

SECTION II INSTALLATION

2.1 GENERAL INFORMATION

This section contains suggestions and factors to consider before installing the KT 76C ATCRBS Transponder. Close adherence to these suggestions will assure a more satisfactory performance from the equipment.

The conditions and tests required for TSO approval of this article are minimum performance standards. It is the responsibility of those desiring to install this article either on or within a specific type or class of aircraft to determine that the aircraft installation conditions are within TSO standards. The article may be installed only if further evaluation by the applicant documents an acceptable installation and is approved by the Administrator.

2.2 UNPACKING AND INSPECTING EQUIPMENT

Exercise extreme caution when unpacking the unit. Make a visual inspection of the unit for evidence of damage incurred during shipment. If a claim for damage is to be made, save the shipping container to substantiate the claim. Save all packing materials for use in unit storage or reshipment.

2.3 EQUIPMENT INSTALLATION

2.3.1 GENERAL

The following paragraphs contain information pertaining to the initial installation of the KT 76C ATCRBS Transponder, including instructions concerning the location and mounting of the supporting antenna.

The equipment should be installed in the aircraft in a manner consistent with acceptable workmanship and engineering practices and in accordance with the instructions set forth in this publication. To ensure that the system has been properly and safely installed in the aircraft, the installer should make a thorough visual inspection and conduct an overall operational check of the system on the ground prior to flight.

CAUTION

AFTER INSTALLATION OF THE CABLING AND BEFORE INSTALLATION OF THE EQUIPMENT, A CHECK SHOULD BE MADE WITH THE AIRCRAFT PRIMARY POWER SUPPLIED TO THE MOUNTING CONNECTOR TO ENSURE THAT POWER IS APPLIED ONLY TO THE PINS SPECIFIED IN THE INTERCONNECT DIAGRAM, FIGURE 2-2.

The KT 76C system installation will conform to standards designated by the customer, installing agency and existing conditions as to the unit location and type of installation. However, the following suggestions should be considered before installing your KT 76C system.

2.3.2 AVIONICS COOLING REQUIREMENTS FOR PANEL MOUNTED EQUIPMENT

The greatest single contributor to increased reliability of all modern day avionics is to limit the maximum operating temperature of the individual units whether panel or remote mounted. While modern day individual circuit designs consume much less electrical energy, the watts per cubic inch

dissipated within avionics units remains much the same because of the high density packaging techniques utilized. Consequently, the importance of providing avionics stack cooling is essential to the life span of the equipment.

While each individual unit may not require forced air cooling, the combined heat load of several units operating in a typical avionics stack will significantly degrade the reliability of the avionics if provisions for stack cooling are not incorporated in the initial installation. Recommendations on stack cooling are contained in Honeywell Installation Bulletin #55. Failure to provide stack cooling will certainly lead to increased avionics maintenance costs and may void the warranty.

2.3.3 KT 76C INTERCONNECT WIRING AND CABLE HARNESS FABRICATION

A. General

The KT 76C ATCRBS Transponder receives primary power from the aircraft power source. Power connections, voltage requirements, circuit breaker requirements are shown on the interconnect diagram (see Figure 2-2).

The length of the wires to parallel pins should be approximately the same length, so that the best distribution of current can be effected. Honeywell recommends that all wires, including spares as shown on the interconnect diagram be included in the fabrication of the wiring harness. However, if full wiring is not desired, the installer should ensure that the minimum wiring requirements for the features and functions to be used be incorporated.

When cables are installed in the aircraft, they must be supported firmly enough to prevent movement and should be carefully protected against chaffing. Additional protection should also be provided in all location where the cable may be subjected to abuse.

In wire bundles, the cabling should not be tied tightly together as this tends to increase the possibility of noise pickup and similar interference. When routing cables through the aircraft the cables should cross high level rf lines at right angles.

The following guidelines are recommended:

- (1) The installing facility will supply and fabricate all external cables. (See Figures 2-5 through Figure 2-9). The required connectors are supplied as part of the installation kit (P/N 050-01577-0001).
- (2) The KT 76C and the associated wiring harness must be kept a minimum of three feet from the transponder antenna coax and the termination connector of the antenna to prevent rf interference from the antenna.
- (3) Do not route the transponder antenna coax near ADF sense or loop antenna cables.

NOTE

The total losses in the coaxial cable run and interconnects between the omni antenna and the KT 76C transponder must be less than or equal to (\leq)2 dB. Use Figure 2-2 as a reference and adhere to the dimensions prescribed in Figure 2-5.

B. Primary Power and Circuit Breaker Requirements and Wiring

The KT 76C transponder receives primary power from an aircraft by aircraft power circuit breakers. The KT 76C is designed to operate from 11-33 V dc. Power connections, wire sizes, and circuit breaker requirements are shown on the interconnection diagram Figure 2-2.

2.3.4 EQUIPMENT LOCATION

Care should be exercised to avoid mounting components near equipment operating with high pulse current or high power outputs such as radar and satellite communications equipment. In general, the equipment should be installed in a location convenient for operation, inspection, and maintenance, and in an area free from excessive vibration, heat, and noise generating sources. All mechanical installation drawings, connector assembly diagrams, interconnect diagrams, and connector pin assignment tables referenced in this section are located at the end of this section of the manual. Determine the mounting location for system components following the guidelines below.

Prior to installing any equipment, make a continuity check of all wires and cables associated with the system. Then apply power and check for proper voltages at system connectors, and then remove power before completing the installation.

A. Transponder And Mounting Tray Locations

The tray-mounted KT 76C ATCRBS Transponder can be installed in any convenient location on the panel that is free from excessive heat and vibration and which provides reasonable access for inspection and maintenance. To achieve maximum performance, the KT 76C should be installed adjacent to other receivers with similar functions.

To allow for inspection or repair of the wiring of the connector assembly itself, sufficient lead length should be left so that when the mounting hardware for the rear connectors and antenna coaxial cable is removed the assembly may be pulled forward several inches. Also, a bend should be made in the harness (at the rear connectors) to allow water droplets that might form on the harness due to condensation, to drip off at the bend and not collect in the connection.

Except for antenna cables, (see Figure 2-5) the length of cables from the KT 76C transponder mounting tray connector to other system units is not critical because unit interfaces are designed with high impedance inputs, low impedance outputs, and low noise susceptibility characteristics.

Forced air cooling is recommended but is not a requirement. Outline drawing Figure 2-3 shows transponder and mounting tray dimensions.

B. Antenna (see Figure 2-4)

The KT 76C antenna should be well removed from other antenna projections, the engine(s), and propeller(s). It should also be well removed from landing gear doors, access doors, or other openings which will break the ground plane for the antenna as a surface directly beneath the antenna should be a flat plane over as large area as possible.

A back-plate should be used for added strength on thin-skinned aircraft.

To prevent rf interference, the antenna must be physically mounted a minimum distance of three feet from the KT 76C and the wiring harness.

The transponder antenna should be mounted a minimum of six feet away from the DME antenna, four feet from the ADF sense antenna, and three feet from TCAS antennas.

Where practical, plan the antenna location to keep cable lengths as short as possible and avoid sharp bends in the cable to minimize the VSWR.

Avoid running other cables or wires near the antenna cable.

On pressurized aircraft, the antenna should be sealed using RTV No. 3145 (P/N016-01082-0000) or equivalent around the connector and mounting hardware.

All antenna mounts should be sealed around from the outside for moisture protection using RTV or equivalent.

Mount the antenna in as clean an environment as possible, away from exhaust gases and oils. The antenna should be kept clean. If left dirty (oil covered), the range of the transponder may be affected.

2.3.5 KT 76C INSTALLATION

The mounting tray for the transponder should be mounted using the dimensions specified in the outline and mounting drawing, Figure 2-3. The mounting tray should be wired according to the system interconnect diagram, Figure 2-2.

A. Transponder Tray

- (1) Rear connector wiring must be completed before permanently fastening the mounting tray to the panel.
- (2) Remove the area specified on the outline and mounting drawing (see Figure 2-3) for front and rear dimensions. Care must be taken to avoid damage to the adjacent equipment and cables.
- (3) Secure the tray to the panel. The mounting tray must be secured in the rear by attaching the tray to a structural member of the airframe.
- (4) Look at the bottom of the unit and confirm the front lobe of the hold-down device is in a vertical position. This can be accomplished by using a 3-32 inch Allen wrench through the front plate.

B. Transponder

- (1) Slide the transponder into the tray until the front lobe touches the mounting tray.
- (2) Turn the Allen wrench clockwise until the rear lobe engages the mounting tray slot. Continue turning the wrench clockwise until tight.

CAUTION

DO NOT OVERTIGHTEN THE LOCKING FASTENER

C. Antenna

(1) General

For L-band blade antenna outline drawing, installation procedures, and mounting dimensions, refer to the manufacture's instructions.

(2) KA 60

- (a) Peel backing off the antenna template and apply the template to the aircraft at the desired mounting location.
- (b) Drill or cut the proper size holes for mounting the antenna, then remove the template.
- (c) Using the antenna as a stencil, draw a line around the base of the antenna where it comes into contact with the aircraft. Then carefully scrape off the paint within the stenciled area. Lightly sand the bare metal with fine sandpaper to insure the removal of all paint and protective coatings.
- (d) Sand the inside area of the aircraft where the backing plate will be located to remove chromate or other protective finish.
- (e) Apply Alumiprep No.33, or equivalent, following the manufacturer's directions to cleanse the metal of any residue.
- (f) Apply Alodine no. 1001, or equivalent, following the directions on the container.
- (g) Align the backing plate with the holes drilled in step (b). Fasten the backing plate securely in place, if required for reinforcement.
- (h) Mount the antenna using #8 star washer and 8-32 fasteners included with the antenna.
- (i) Coaxial cable RG400, or equivalent, is normally used on installations having a cable run of eleven feet or less. For cable runs from ten to 32.5 feet, use low loss antenna parts, refer to Section 1 paragraph 1.4.2 or 1.5.
- (j) Inspect coaxial cable connector for proper contact, then fasten the connector securely to the antenna.

D. Programming Options

The VFR code and display brightness can be programmed and their values stored in EEPROM. To program the VFR code or display brightness parameters please refer to Sections 3.2.2.C. or 3.2.2.F.(1), respectively.

2.3.6 VOLTAGE CHANGEOVER INSTRUCTIONS

The KT 76C is designed to operate with an input voltage of 11-33 V dc. The panel lamps are internally wired to operate from either a 14 V dc, or 28 V dc panel lighting system, depending on the connections at the rear connector. Details of this panel lighting option are shown on the interconnect drawing Figure 2-2. No internal wiring changes are required.

2.3.7 KT 76A/KT 78A TO KT 76C - CHANGEOVER INSTRUCTIONS

If the KT 76C will be installed in place of an existing KT 76A/78A installation follow the procedures below.

A. Power Requirements

(1) Voltage Change Kit Removal

On 28 V dc installations a voltage changeover kit (P/N 050-01578-0000) was installed. The 10- Ω , 55-W, resistor, (132-00113-0004) must be removed from pin 11 in the wiring harness.

(2) Additional Supply Line (Recommended but not required)

Add pin 12 to support the additional current (see Figure 2-2, sheet 1, for details).

(3) Change the harness fuse from 3 A to 5 A current rating.

(4) The RFI Suppression Adaptor (P/N 071-02010-0000) must be removed if it was installed.

B. Additional Features

The following pin may be added to obtain the additional feature:

Pin 4	Suppression Line In/ Out
-------	--------------------------

2.3.8 MOLEX CONNECTOR ASSEMBLY PROCEDURE

The KT 76C uses a special connector that mates directly with the printed circuit board inside the unit (see Figure 2-1). Assemble the connector using the following procedure:

A. Solderless Contact Terminal Assembly using Molex Crimper
Refer to instructions in Figure 2-1.

B. Solderless Contact Terminal Assembly using Pliers

- (1) Strip each wire 5/32 inches for contact terminal (P/N 030-01107-0024). The last two digits of the contact terminal part number indicates the number of terminals furnished.
- (2) Tin the exposed conductor.
- (3) Using needle nosed pliers, fold over each conductor tab, in turn, onto the exposed conductor. When both tabs have been folded, firmly press the tabs against the conductor.
- (4) Repeat step (3) for insulator tabs.
- (5) Apply a small amount of solder (using minimum heat) to the conductor/tab connection to assure a good electro-mechanical joint.

C. Contact Insertion into Molex Connector Housing

- (1) After the contact terminals have been installed on the wiring harness, the contact terminals can be inserted into the proper location in the connector housing (P/N030-01094-0066). The terminal cannot be inserted upside down. Be sure to push the terminal all the way in, until a click can be heard or felt.
- (2) The self-locking feature can be tested by gently pulling on the wire.

D. Extraction of Contact from Molex Connector

- (1) Slip the flat narrow blade of a Molex contact ejector tool, HT-1884 (Honeywell P/N 047-05099-0001), under the contact on the mating side of the connector. By turning the connector upside down one can see the blade slide to the stop.

- (2) When the ejector is positioned against the stop the locking key of the contact is raised, allowing the contact to be removed by pulling moderately on the lead.
- (3) Neither the contact or position is damaged by removing a contact; however, the contact should be checked visually before reinstalling in connector, to be certain that retaining tab “A” extends as shown (see 2-1) for retention in connector.

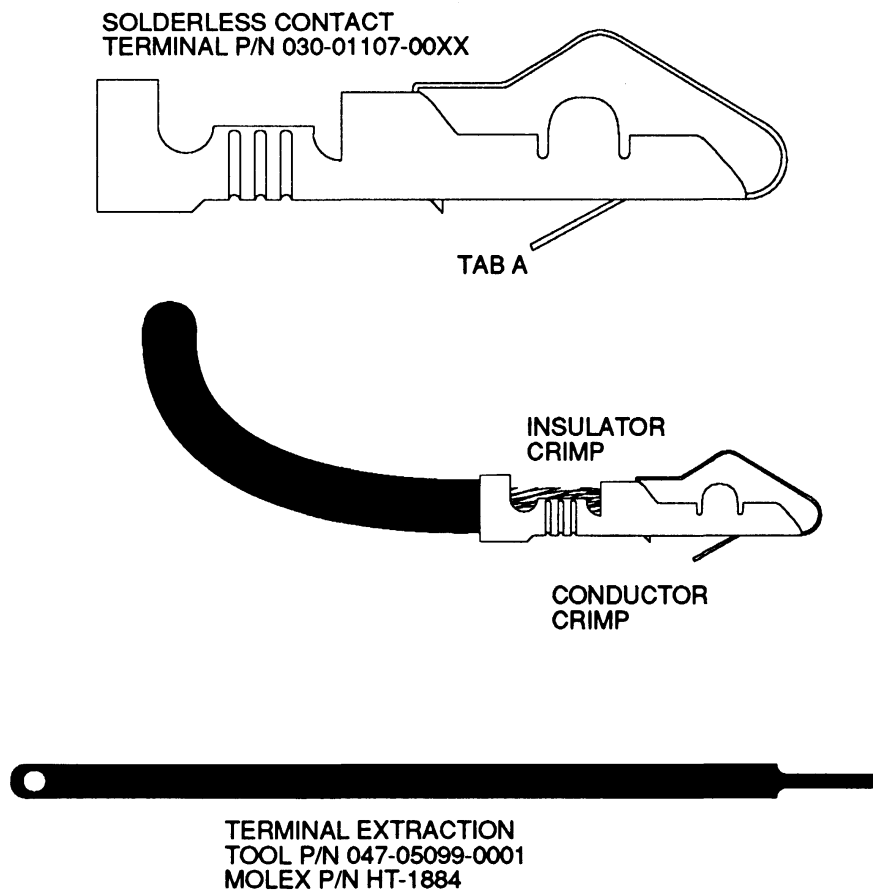

**FIGURE 2-1 Crimping Tool
(Sheet 1 of 3)**

Holding the hand crimpers as shown, release the crimper's ratchet pawl and open by squeezing tightly on the handles, and then releasing pressure.

HAND CRIMPER
P/N 071-06041-0000
MOLEX P/N 6115

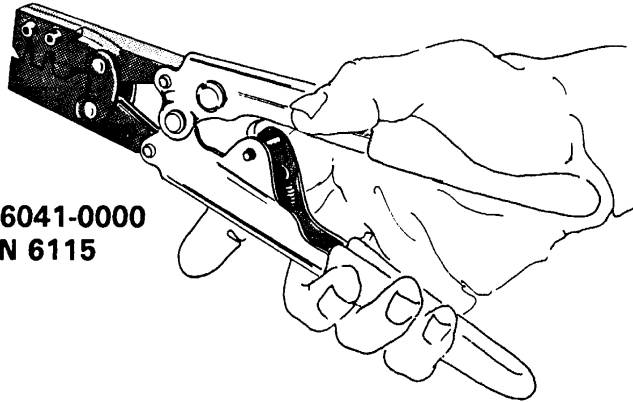

Close crimpers until ratchet begins to engage. Then insert terminal into jaws from the back side. (See the following; Figure 2-1). For 24 to 30 AWG wire, it will be necessary to start the crimp in jaw A and then complete in jaw B.

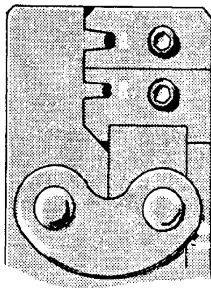

JAW	TERMINAL	WIRE SIZE	INSULATION RANGE
A	030-01107-0030	18 to 24 AWG	.110 TO .055
B	030-01107-0030	24 to 30 AWG	.055 to .030

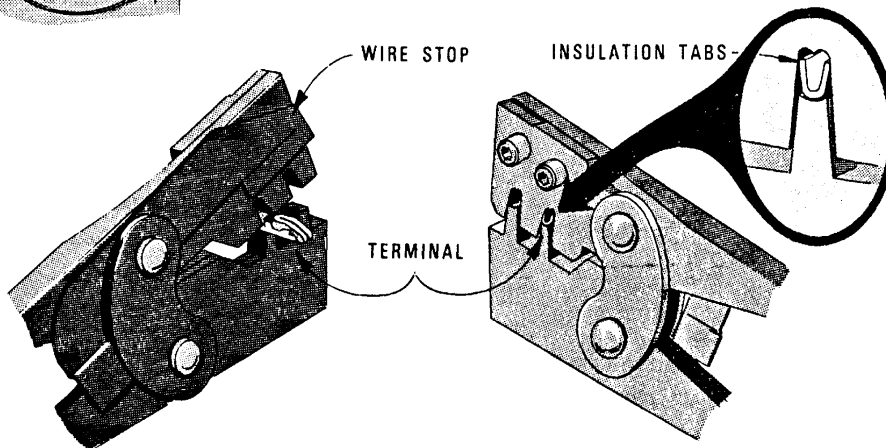

Terminal is in the correct position when insulation tabs are flush with outside face of crimp jaws.

FIGURE 2-1 Crimping Tool
(Sheet 2 of 3)

Once the terminal is in the correct position, close the jaws gently until the terminal is held loosely in place. Push the wire stop down so that it rests snugly behind the contact portion of the terminal.

Strip off 1/8 inch of the wire insulation and insert the wire through the insulation tabs into the conductor tabs until the insulation hits the conductor jaw face or until the conductor touches the wire stop.

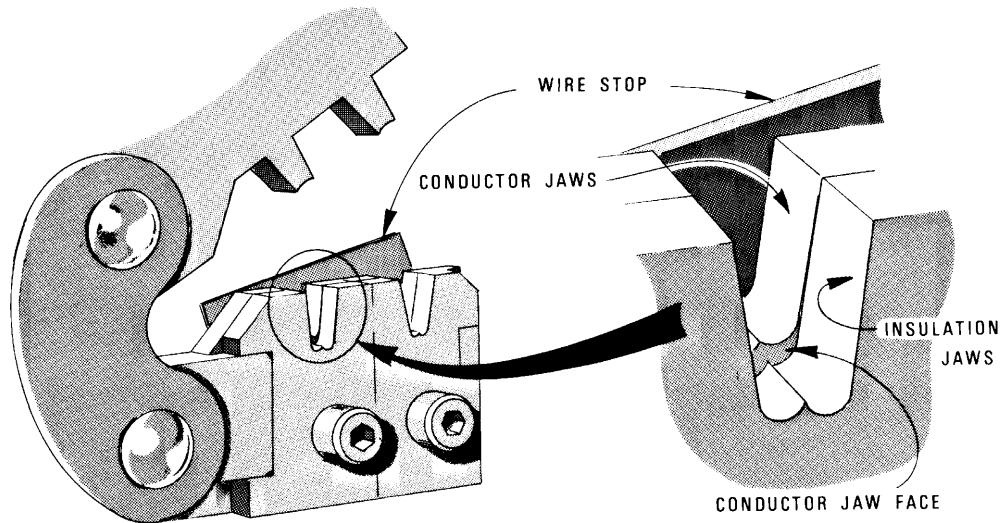

Squeeze the handles until the crimp jaws close and the ratchet releases.

Straighten the terminal if necessary, then release the plier grips and remove the crimped terminal.

CRIMPING PRESSURE ADJUSTMENT

If too much or too little pressure is needed to release the crimper's ratchet pawl at the end of the crimp stroke, the ratchet can be easily adjusted. A spanner wrench provided with the tool can be used to loosen the lock nut, and rotate the keyed stud clockwise for increased pressure and counter-clockwise for decreased pressure. Once the desired pressure has been set, the lock nut must be tightened again. Newer models may have a screwdriver adjustment.

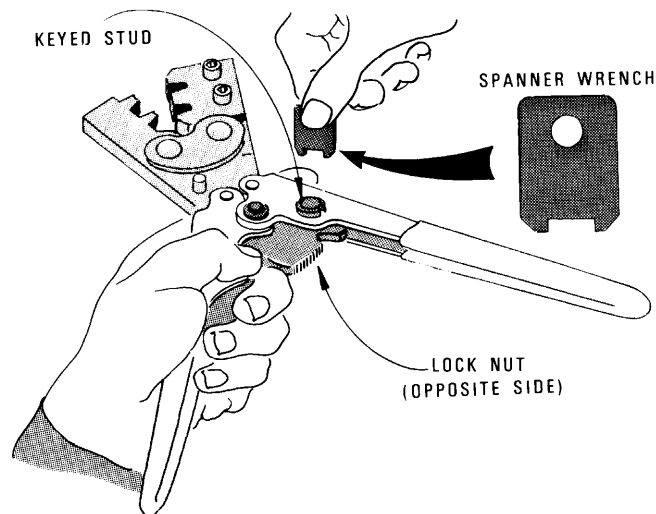

**FIGURE 2-1 Crimping Tool
(Sheet 3 of 3)**

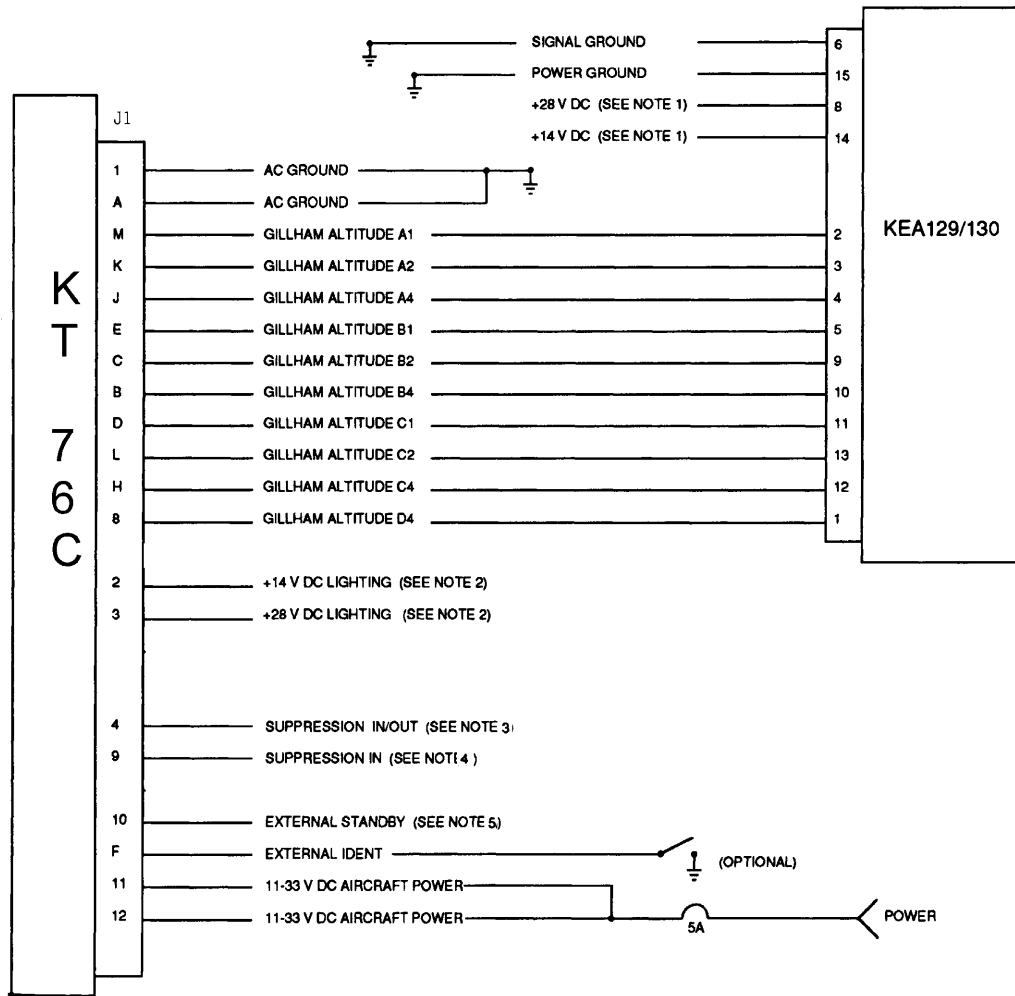

NOTES:

1. DO NOT CONNECT PINS 8 AND 14 TOGETHER. DO NOT CONNECT TO PINS 11 OR 12 OF KT76C.
2. FOR 28 VDC LIGHTING, CONNECT 28 VDC LIGHT DIMMER TO PIN 3 AND LEAVE PIN 2 OPEN. FOR 14 VDC LIGHTING, CONNECT 14 VDC LIGHT DIMMER TO PIN 2 AND GROUND PIN 3.
3. CONNECT TO ANY STANDARD ARINC SUPPRESSION LEVEL, SUCH AS KN 63 OR KDM 706, USING COAX GROUND AT BOTH ENDS. SEE SECTION 1.3.1
4. ACCEPTS POSITIVE GOING SUPPRESSION FROM KN 62A OR KNS 80. SEE SECTION 1.3.
5. THIS PIN IS USED FOR DUAL XPDR INSTALLATIONS. GROUNDING EXTERNAL STANDBY PLACES THE XPDR IN "STANDBY".
6. ALL WIRES, OTHER THAN COAX SHIELD, WILL BE #22 GAUGE.



FIGURE 2-2 KT 76C Interconnect Diagram (Sheet 1 of 3)

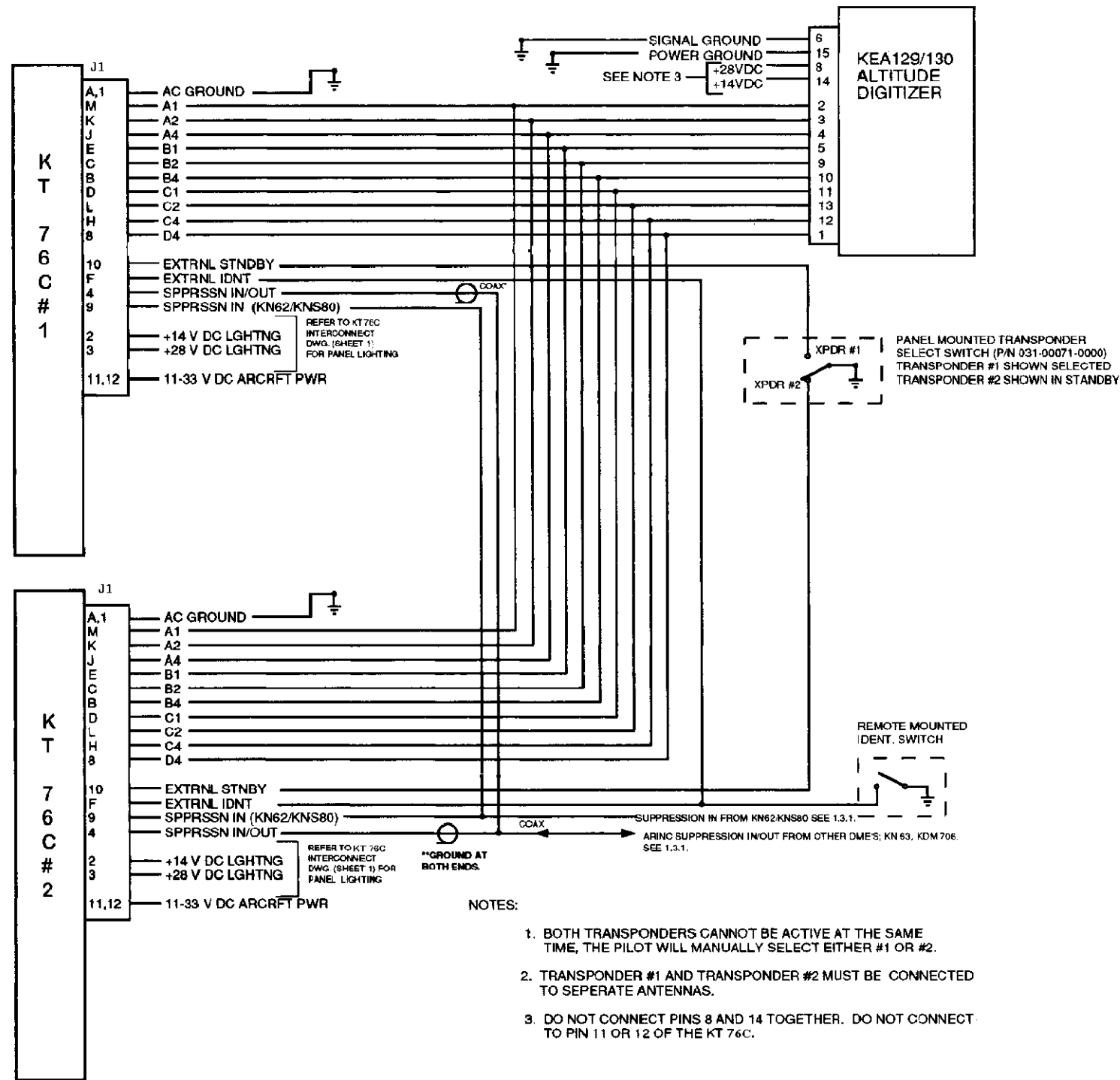
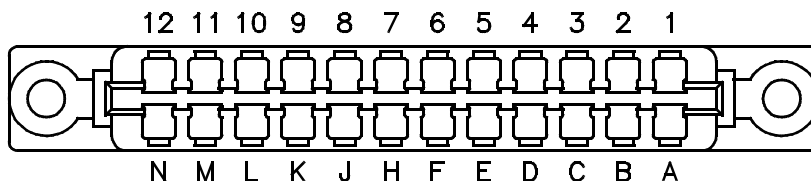

FIGURE 2-2 KT 76C Interconnect Diagram (Sheet 2 of 3)

THIS PAGE BLANK



Main Connector - J1 Front View

<u>Pin Number</u>	<u>Description</u>
1.....	Aircraft Ground
2.....	14 V Lighting (See Note)
3.....	28 V Lighting
4.....	Suppression In/Out
5.....	+5 Vdc Test Point
6.....	-6.2 Vdc Test Point
7.....	Reserved
8.....	Gillham Altitude D4
9.....	Suppression In
10.....	External Standby
11.....	11-33 V dc Aircraft Power
12.....	11-33 V dc Aircraft Power
A.....	Aircraft Ground
B.....	Gillham Altitude B4
C.....	Gillham Altitude B2
D.....	Gillham Altitude C1
E.....	Gillham Altitude B1
F.....	External Ident
H.....	Gillham Altitude C4
J.....	Gillham Altitude A4
K.....	Gillham Altitude A2
L.....	Gillham Altitude C2
M.....	Gillham Altitude A1
N.....	+9 Vdc Test Point

Antenna Connector - J2

<u>Pin Number</u>	<u>Description</u>
1.....	Antenna

**FIGURE 2-2 KT 76C Interconnect Diagram
(Sheet 3 of 3)**

2.4 POST INSTALLATION TEST PROCEDURE

2.4.1 TRANSPONDER SYSTEM CHECKOUT

The post-installation test is used to apply power and functionally checkout the system. Successful completion of the post-installation test verifies the proper operation of the KT 76C ATC Transponder System.

Table 2-1 is a visual inspection/check procedure that should be performed after system installation as part of a system checkout. A post-installation test per paragraph 2.4.1.B should be performed. In addition, the procedure should be used as a periodic maintenance inspection check.

TABLE 2-1 Inspection/Check Procedure

EQUIPMENT	INSPECTION/CHECK PROCEDURE
KT 76C ATCRBS Transponder	A. Inspect external surface for damage
	B. Check that the unit is securely installed and that retaining mechanism is securely tightened.
	C. Ensure that all connections in the mounting tray are properly mounted and secure.
Antennas	A. Inspect external surfaces for damage.
	B. Check that antenna is properly mounted and mounting screws are tight.
	C. Ensure that antenna coaxial cable connectors are properly mated and secure.

A. Inspection

Perform the following inspection on the overall system:

- (1) Check that cables do not interfere with aircraft controls or other equipment.
- (2) Check cabling for proper routing and check security of tie-down points. Inspect and adjust cable runs to ensure that cables are not strained, kinked, or severely twisted and are not exposed to rough or sharp surfaces.

B. Post-Installation Test/Operation

(1) General

Installation of the transponder system requires three stages of testing to ensure the proper operation of the transponder. Initially, prior to the installation of the transponder and antenna, a system interwiring check should be performed. This check verifies that the aircraft and all transponder interconnections are correct, before power is applied. After the units are installed a visual inspection of the equipment and connections is made.

(2) System Interconnect Check

To check the aircraft and transponder system interconnections proceed as follows:

- (a) Check that all cables and interwiring are installed in accordance with the Interwiring and Cable Harness Fabrication instructions (paragraph 2.3.3).
- (b) Using the interconnect diagram (see Figure 2-2), check wiring for proper destination, opens, and shorts.
- (c) Check rf cables for insertion loss and VSWR.

(3) Visual Inspection

In conjunction with system installation, perform the inspection/check procedure (Table 2-1 in this section).

(4) Post-Installation Test

The Post-Installation Test verifies the proper operation of the KT 76C Transponder System. Utilizing the self-test function and a ramp tester, this procedure is used after the system units have been installed and thereafter as an operational check. This procedure is comprised of a pretest setup, manual test and ramp test. The following tests are performed on the ground.

(a) Pretest Setup

- 1) Check KT 76C system source power as follows:
 - a) Confirm that aircraft 11-33 V dc is operational.
 - b) Confirm that the aircraft panel background lighting power source is operational by adjusting the cockpit dimmer switch for proper cockpit panel illumination.
- 2) Operate appropriate aircraft circuit breakers and switches to apply power to the system as follows:
 - a) Apply 11-33 V dc to transponder #1 and if applicable transponder #2.
 - b) Apply primary power inputs to all that interfaces with the transponder(s) per the system configuration.
- 3) Verify that all KT 76C circuit breakers are closed.
- 4) Allow for warm-up.
- 5) Verify the 4096 code is annunciated on the ATC IDENT code display with mode select switch in the "SBY" position.

(b) Self-Test

The KT 76C transponder self-test is initiated from the front panel.

- 1) On the KT 76C rotate the Mode select knob to "TST". Verify that all segments on both the altitude and ident windows on the display illuminate.

(c) Manual Test

This test checks the ATC IDENT code switches and display.

- a) Verify that the ID code entry is initiated by pressing one of the eight code selection switches. The left most significant (MSB) display digit will change to reflect the code selection switch that was pressed and the remaining three display digits are replaced by dashes. Subsequent ID code digits may be entered by pressing the appropriate code selection switch.

The next displayed digit will change to reflect the code selection switch that was pressed. This sequence continues until the last digit (LSB) is entered. The new 4 digit code should now be displayed.

- b) Verify that pressing the CLR push-button switch replaces the last digit entered with a dash (-). Subsequent presses of the CLR push-button will replace existing digits with dashes, until the display is all dashes.
 - c) Verify that after four to six seconds of no activity on the CLR, VFR, or Code Selection switches, the display reverts back to the previously entered code.
- (d) Conformity Inspection

Visually inspect the installed equipment to determine the use of acceptable workmanship and engineering practices. Verify that all mechanical and electrical connections have been made properly.

- (e) Ramp Test

The following test will be conducted to verify operation.

Reply Frequency - Verify that the reply frequency is 1090 +/- 3 MHz.

C. Ramp Test (optional)

This test requires the use of an ATCRBS Ramp Tester. Specific instructions for operating the ramp tester are contained in the applicable operator's manual. In systems with dual transponders and altitude sources configure the system to check each function. Table 2-2 lists tests that will be performed during ramp testing. In addition, Table 2-2 contains a brief description of each test and the pass/fail criteria.

TABLE 2-2 Ramp Tests

TEST	DESCRIPTION	PASS/FAIL CRITERIA
RF Power Output	Measures the effective radiated power output from the antenna.	Minimum of 125 watts.
RF Frequency	Measures the transmit frequency.	1090 MHz +/- 3 MHz.
ATCRBS Receiver Sensitivity	Measures the receiver minimum triggering level (MTL) for a 90% reply rate.	-73 dBm +/- 4.0 dBm.
ATCRBS SLS Level	Checks sidelobe suppression function by varying the SLS pulse level and monitoring transponder reply rates.	Reply if P1 exceeds P2 by 9 dB or more. No reply if P2 equals or exceeds P1.
ATCRBS Reply	Verifies Transponder replies to Mode A and Mode C interrogations. Measures F1 to F2 spacing and duration of pulses.	Replies to interrogations. F1 to F2 spacing, 20.3 μ sec +/- 0.1 μ sec. F1 and F2 pulse width, 0.45 μ sec +/- 0.10 μ sec.
Ident	Verifies Ident function is operating.	Reply with SPI present in ATCRBS Mode A only.

THIS PAGE RESERVED BLANK

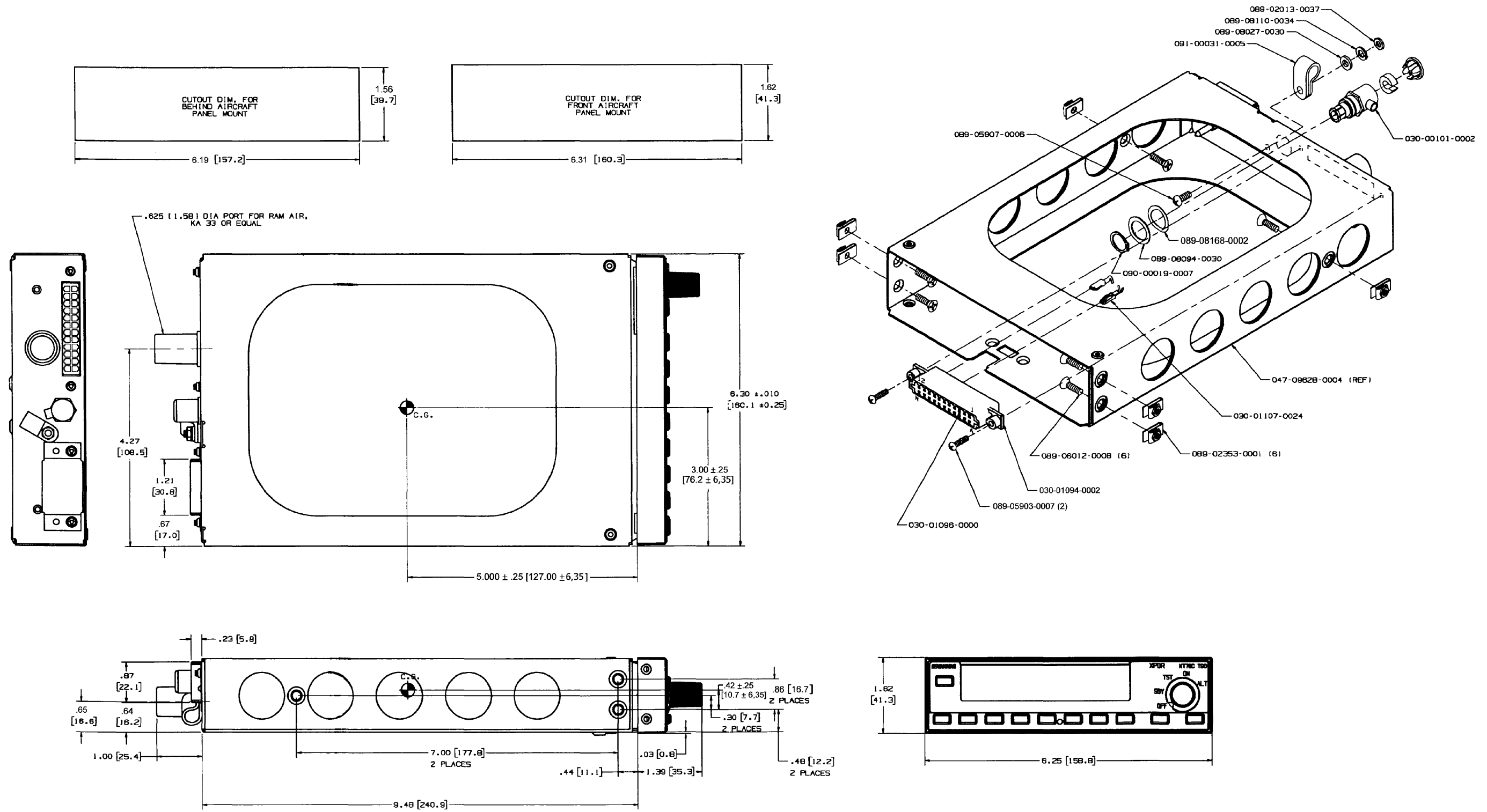

- NOTES:
 1. DIMENSIONS IN BRACKETS ARE IN MILLIMETERS.
 2. WEIGHT: WITHOUT MOUNTING RACK 2.25 +/- 0.25lbs. (1.021 +/- 0.12kg)
 WITH MOUNTING RACK 2.61 +/- 0.25lbs. (1.184 +/- 0.12kg)

**FIGURE 2-3 KT 76C Transponder Installation Drawing
 (Dwg No 155-06039-0000, Rev AB)**

Dwg 155-06039-0000 Rev AB

THIS PAGE BLANK

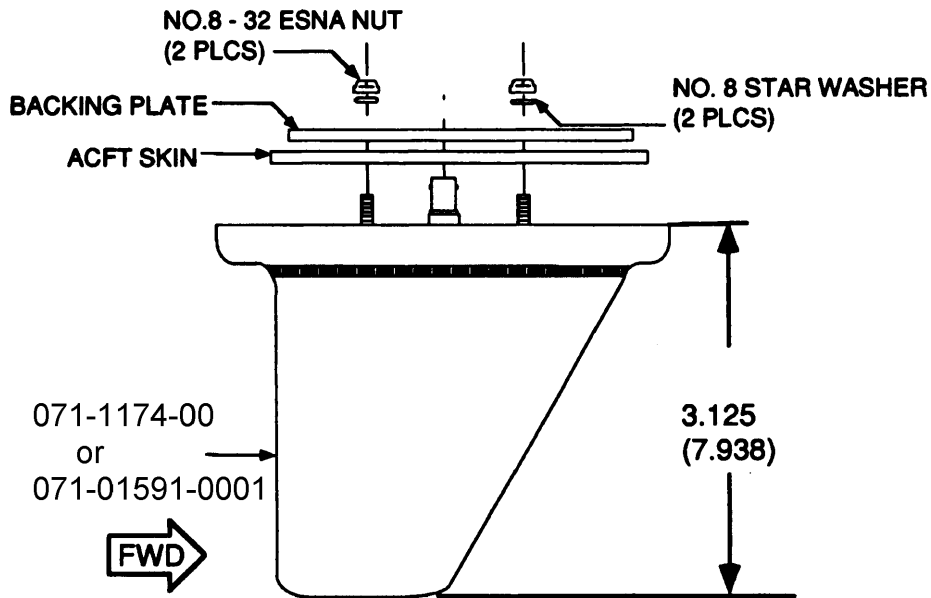

MOUNTING HOLE CUTOUT DIAGRAM

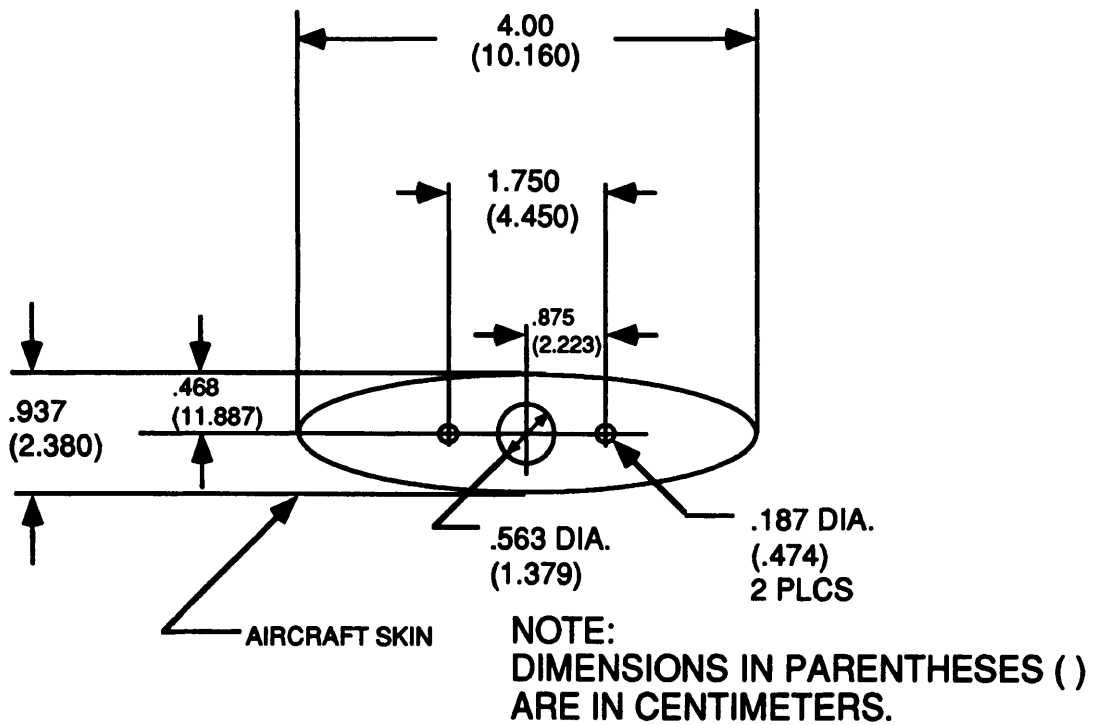
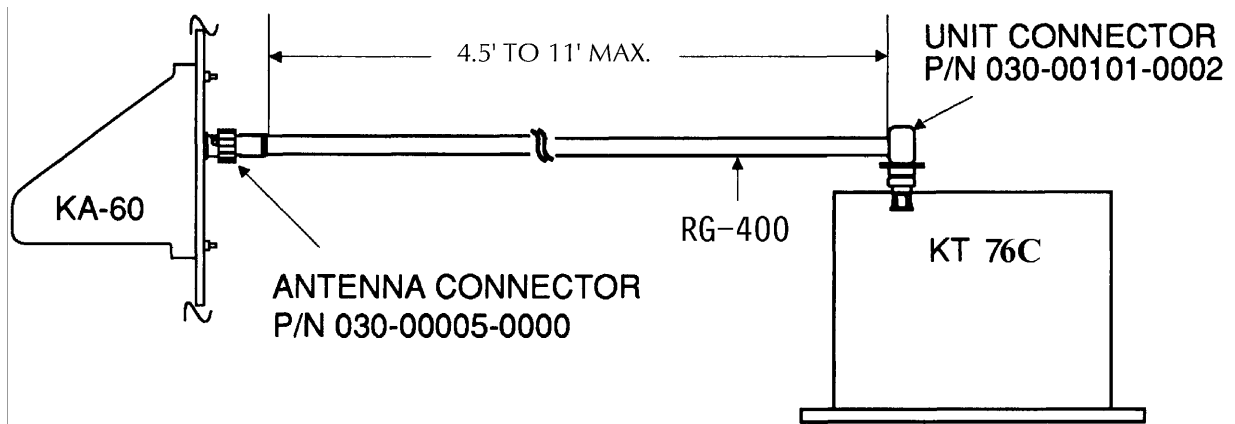

FIGURE 2-4 KA 60 Antenna Installation Drawing



**FIGURE 2-5 Acceptable Cable Connections Drawing
(Sheet 1 of 2)**

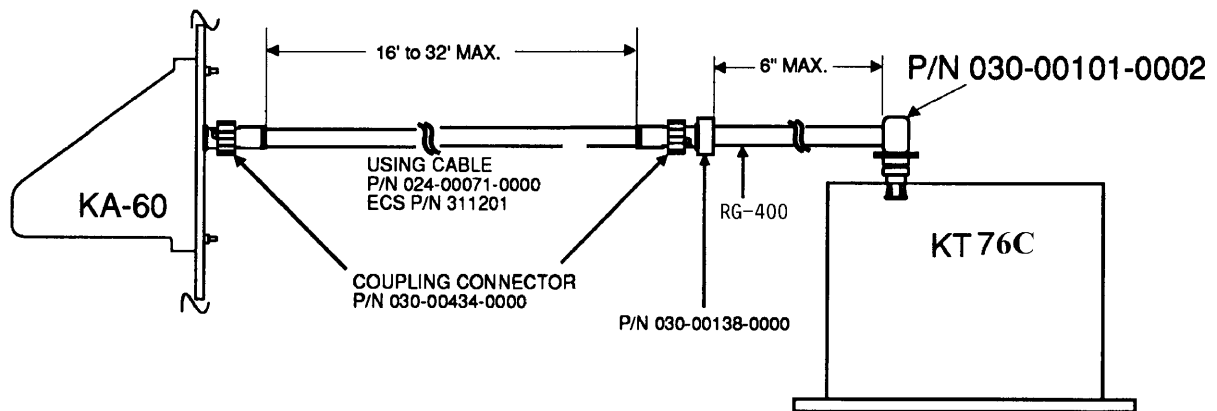
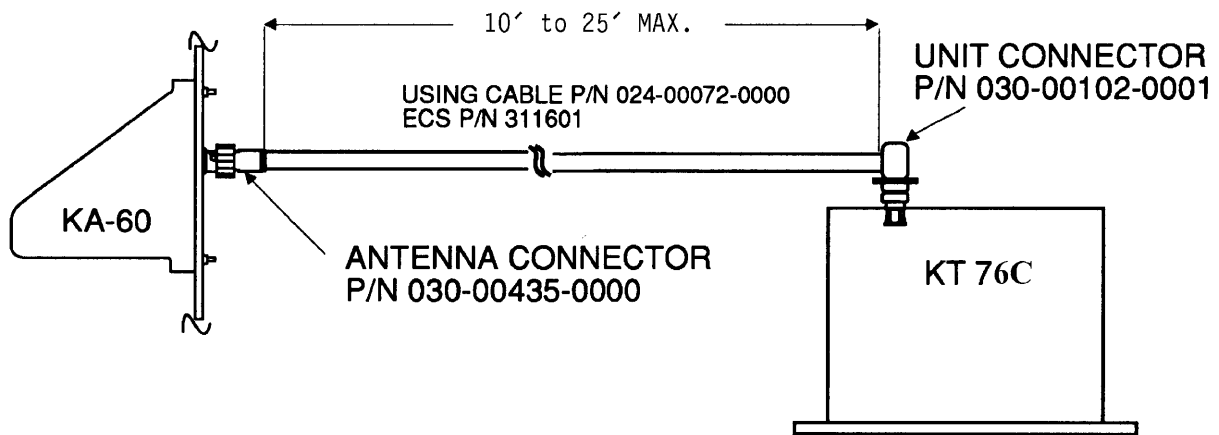
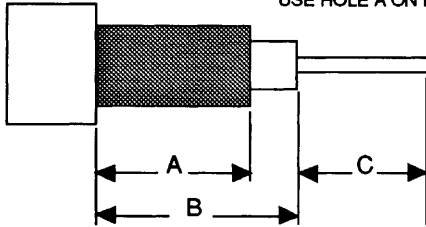

FIGURE 2-5 Acceptable Cable Connections Drawing
(Sheet 2 of 2)

CRIMP TOOL CHART			
CONTACT		TUBE	
TURR HEAD	CABLE	TOOL FRAME	TOOL DIE
SOLDER	311201	M22520/5-01	M22520/5-33
SOLDER	311601	M22520/5-01	M22520/5-19*

*USE HOLE A ON DIE #M22520/5-19 FOR CABLE P/N 311601



STRIPPING DIMENSIONS			
CABLE	A	B	C
311201	.40	.53	.21
311601	.40	.55	.78

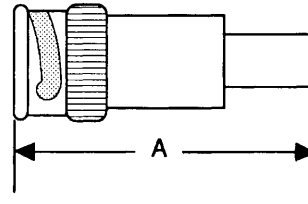

ECS P/N	CABLE	DIMENSION A
CBS122	311201	1.94

PART NUMBER	A	B	C	D	E
CBS922	.152	.228	.261	.297	.750

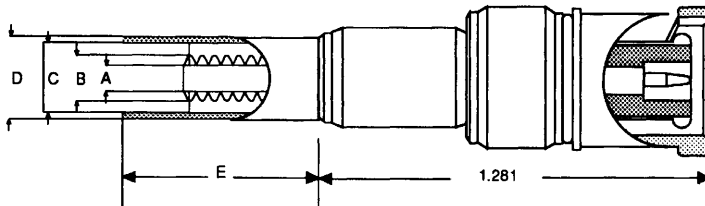

INSTALLATION INSTRUCTIONS:

1. SLIDE TUBE ONTO CABLE
2. CUT OUTER JACKET (SEE CHART)
3. STRIP LENGTH OF CENTER CONDUCTOR (SEE CHART)
4. INSTALL CENTER PIN
5. FLAIR OUT WIRE BRAID
6. CUT INNER SHIELD
7. PUSH BODY ON FIRMLY UNTIL CENTER PIN SEATS
8. TRIM EXCESS BRAID AND PUSH TUBE ONTO CONNECTOR
9. CRIMP TUBE

NOTE: DO NOT NICK BRAID OF CENTER CONDUCTOR

CONNECTOR CROSS REFERENCE CHART		
	TED	ECS
030-00435-0000	4-10-154 SOLDER	CBS 922 CRIMP
030-00434-0000	4-10-153 SOLDER	CBS 122 CRIMP
		ECS REQUIRES CRIMPING TOOLS. SEE CRIMP TOOL CHART.

FIGURE 2-6 Cable Connector Drawing

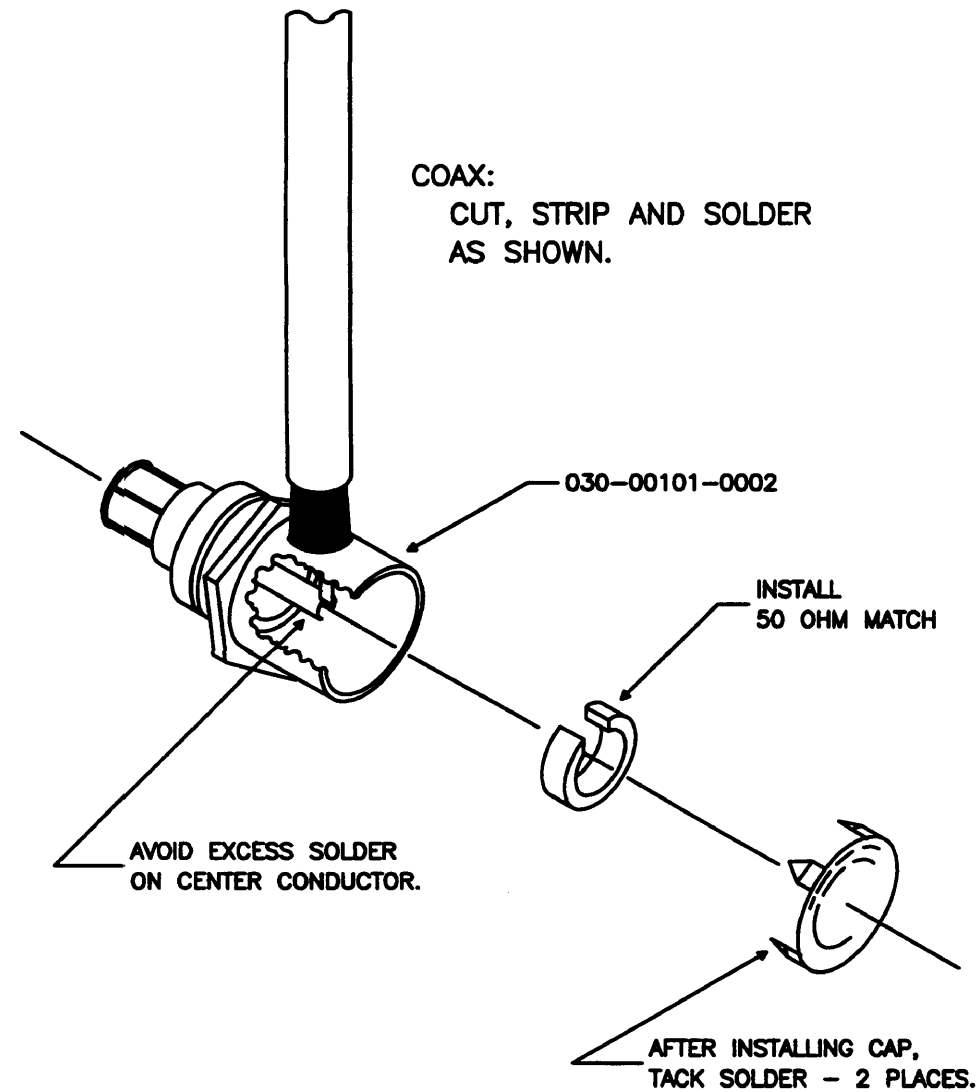

NOTES:

1. WHEN SOLDERING, AVOID APPLYING EXCESS HEAT TO CONNECTOR BODY, HEAT SINK SPRING CONTACTS, AND CENTER CONDUCTOR INSULATOR.

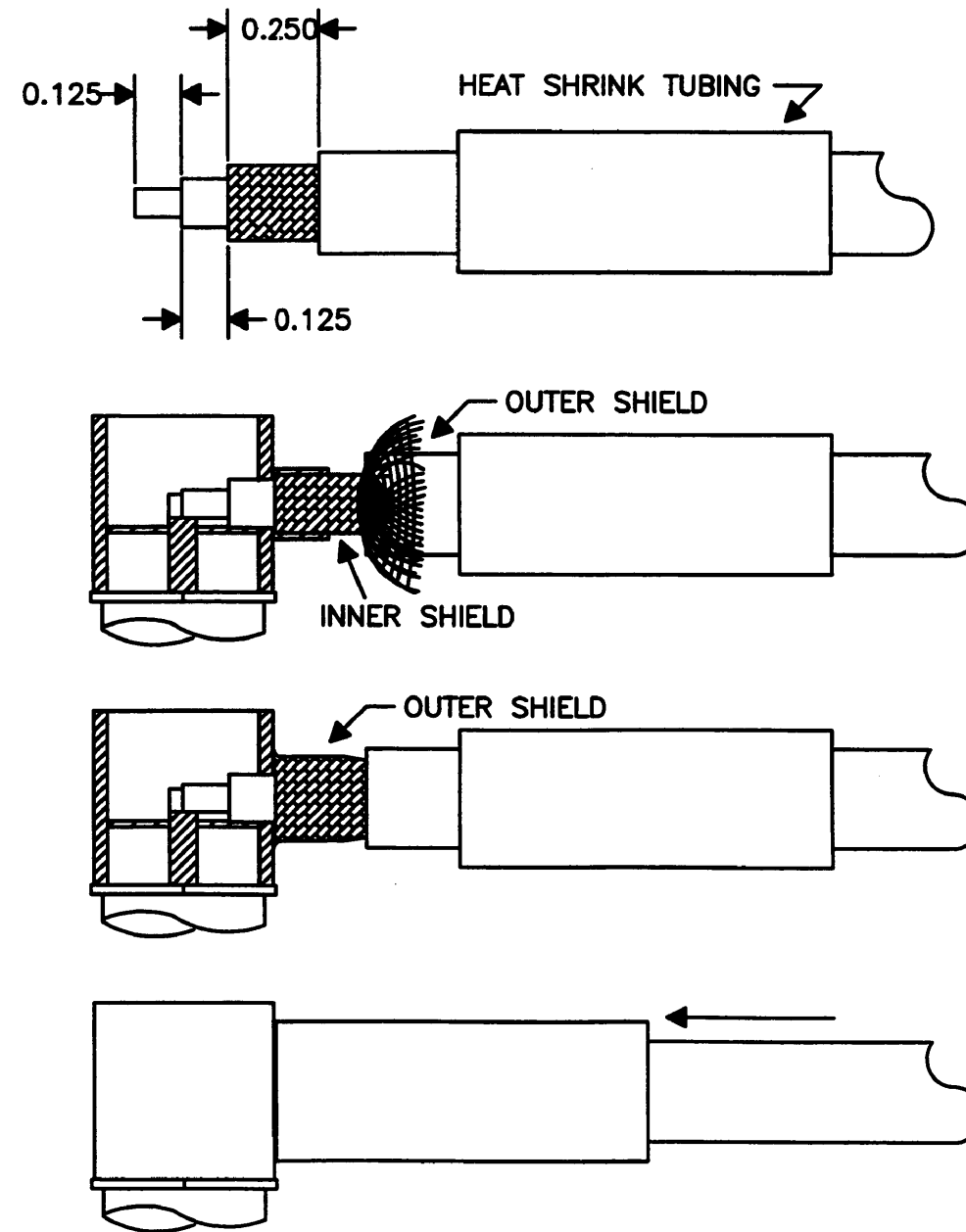

1. STRIP CABLE (P/N 024-00051-0060) OR (P/N 024-00072-0000) * AND PLACE 1" HEAT SHRINK TUBING (P/N 150-00025-0010) OVER COAX.

SOLDER CENTER CONTACT AND SOLDER INNER SHIELD INSIDE. SEE NOTE 1.

3. SOLDER OUTER SHIELD OUTSIDE. SEE NOTE 1.

4. SLIDE HEAT SHRINK TUBING FORWARD (FLUSH WITH CONNECTOR) AND ADD HEAT TO SHRINK THE TUBING.

**USE CONNECTOR 030-00101-0002 FOR CABLE:
RG-400 HONEYWELL P/N 024-00051-0060
* FOR ECS CABLE P/N 311601
HONEYWELL P/N 024-00072-0000,
USE CONNECTOR 030-00102-0001**

FIGURE 2-7 KT 76C RF Connector Assembly Drawing

THIS PAGE BLANK

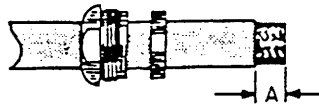

Place nut and gasket over cable and cut jacket to dimension shown.

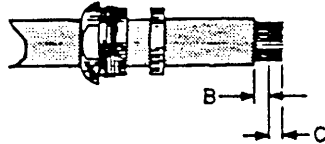

Comb out braid and fold out. Cut cable dielectric to dimension shown. Tin center conductor.



Pull braid wires forward and taper toward center conductor. Place clamp over braid and push back against cable jacket.

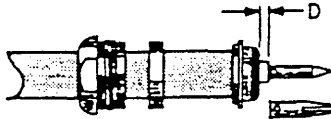

Fold back braid wires as shown, trim to proper length (D) and form over clamp as shown. Solder contact to center conductor.



Insert cable and parts into connector body. Make sure sharp edge of clamp seats properly in gasket. Tighten nut.

EXAMPLE

PART NUMBER	SIZE	DIMENSION			
		A	B	C	D
	RG/U CABLE				
024-00075-0000	393	9/32	1/8	5/32	3/64
024-00051-0060	400	9/32	1/8	5/32	3/64

FIGURE 2-8 TYPE "N" AND "C" Connector Assembly Drawing

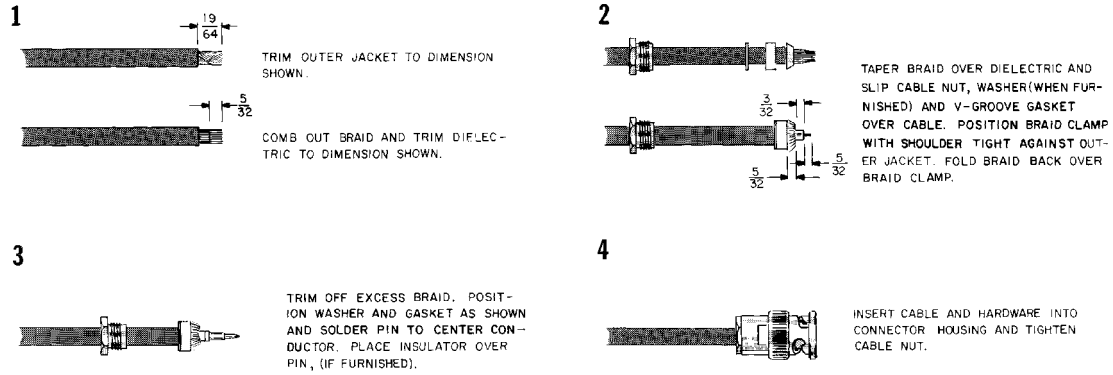

FIGURE 2-9 BNC Connector Cable Assembly Drawing

SECTION III OPERATION

3.1 GENERAL

The following paragraphs describe the operation of the KT 76C. Illustrations of the displays are furnished to assist the operator in understanding the operation of the unit and also provide a visual aid for programming sequences.

NOTE

The KT 76C, and all other avionics, should be turned off before starting the aircraft engine(s).

3.2 DETAILED OPERATING MODES

3.2.1 FUNCTIONAL MODES

The mode is selected by the mode select knob, see the display below for the location of front panel features (see Figure 3-1).

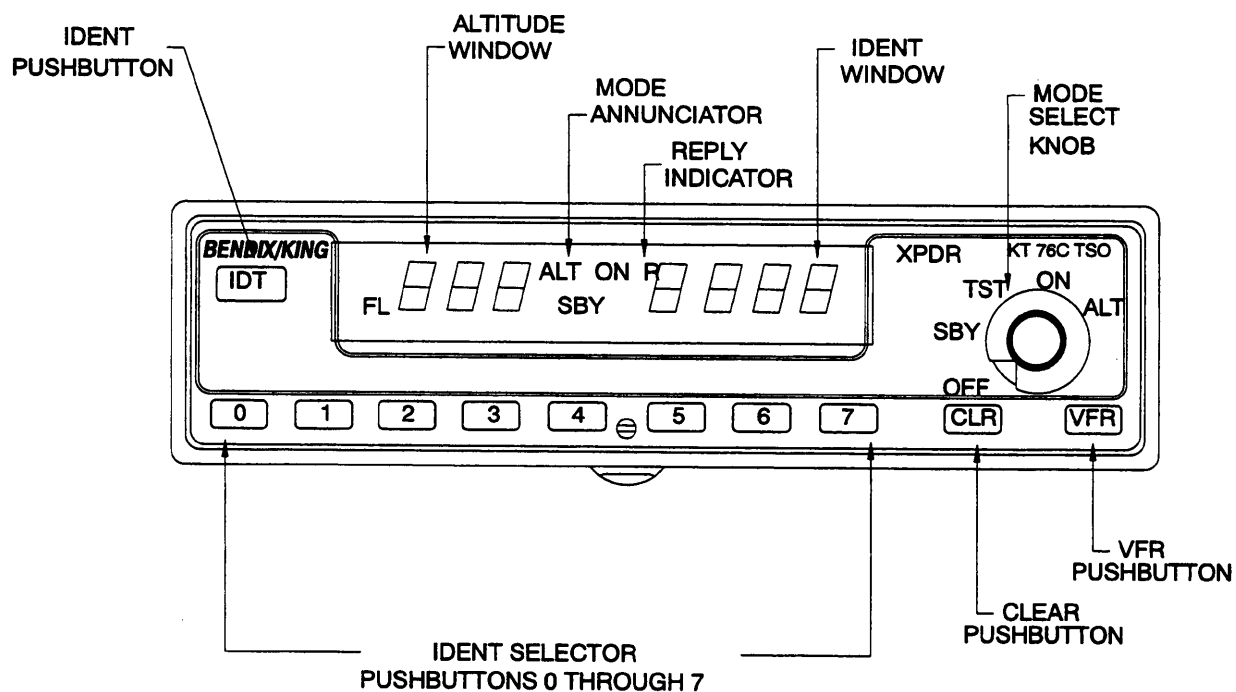

FIGURE 3-1 Unit Functions

OFF - The unit is not energized.

NOTE

A pictorial of the "OFF" mode is not reflected; all segments are off (not lit) during the "OFF" mode.

Standby - The unit is energized, but is inhibited from replying to any interrogation. "SBY" is annunciated on the display in this mode. The altitude display is blank (see Figure 3-2).

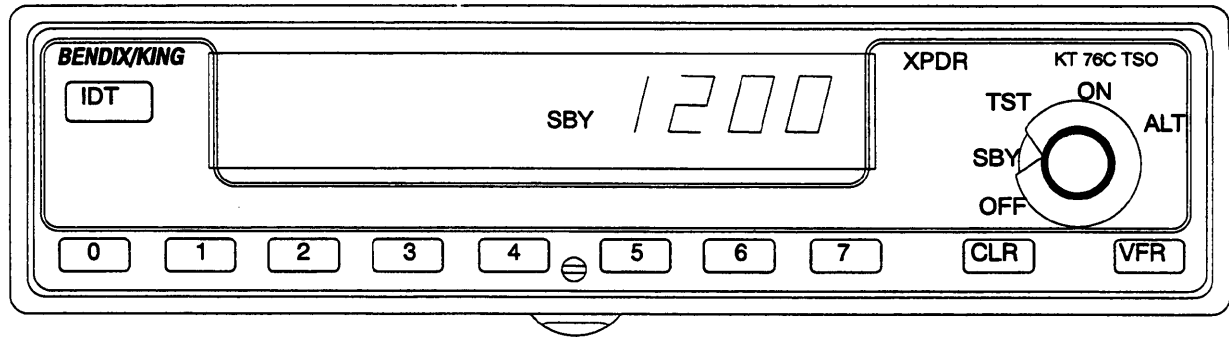

FIGURE 3-2 Standby

TST - The unit will illuminate all segments. The unit will remain in TST mode until the mode selection is changed (see Figure 3-3).

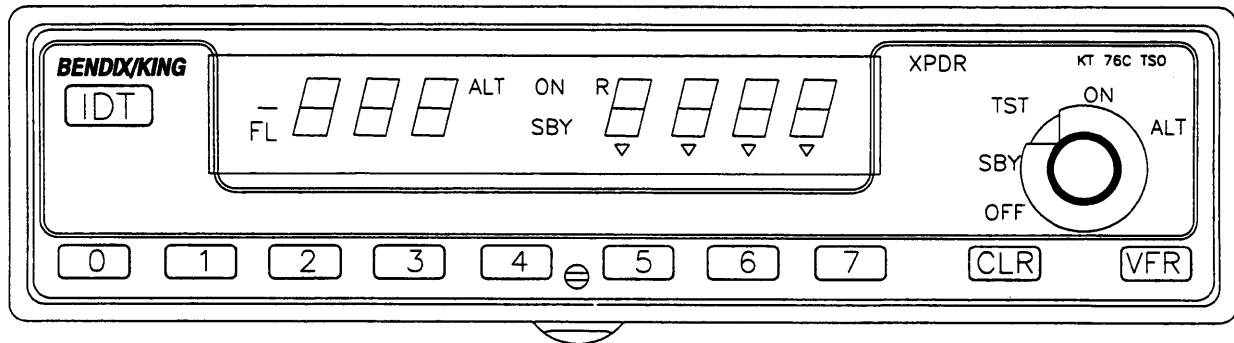

FIGURE 3-3 Test

On - The unit is able to reply to all valid Mode A and Mode C interrogations, however; the altitude information of Mode C reply is suppressed. The altitude display is blank and the ID 4096 code is displayed on the right. "ON" is annunciated on the display in this mode (see Figure 3-4).

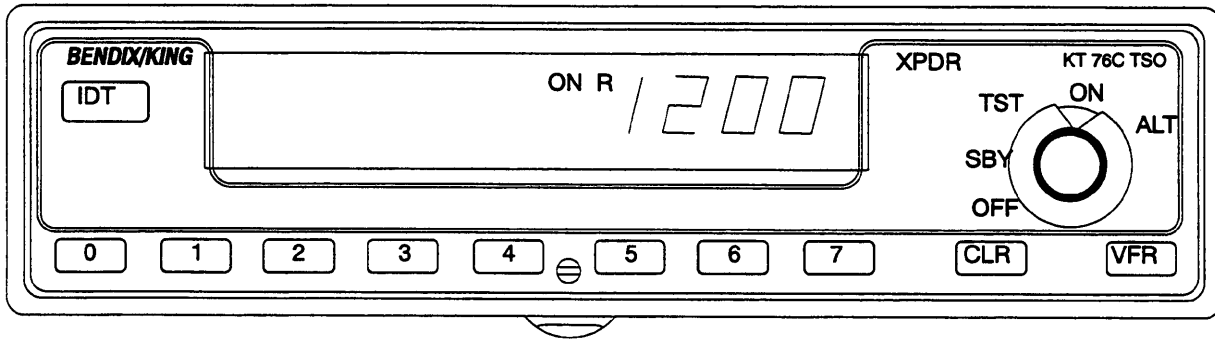

FIGURE 3-4 Unit ON

Altitude - The unit is able to reply to all valid Mode A and Mode C interrogations. The altitude information will be sent in Mode C replies. The ID 4096 code will be displayed on the right and the altitude displayed on the left. "ALT" and "FL" are annunciated on the display in this mode (see Figure 3-5).

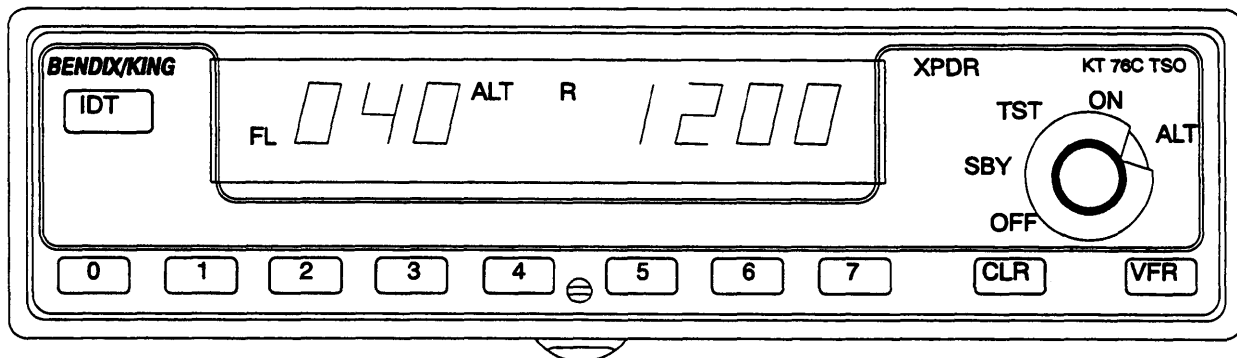

FIGURE 3-5 Altitude

3.2.2 FRONT PANEL OPERATION

A. IDENT

Depressing the "IDT" push button causes the special position identification pulse (SPI) to be appended to Mode A replies for a period of 18 ± 2 seconds. During this period the KT 76C will annunciate the "R". An input pin is provided on the rear connector for an external ident pushbutton (see Figure 3-6).

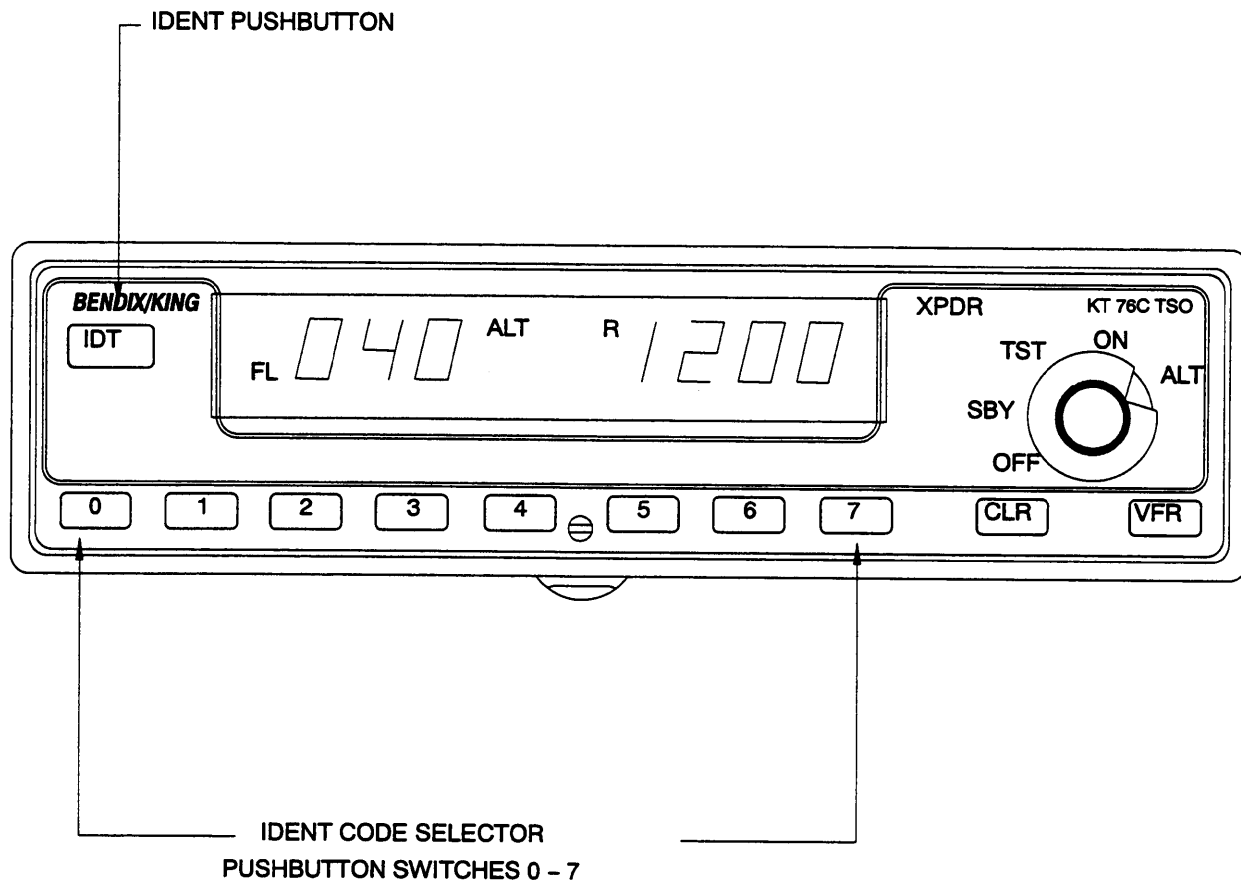

FIGURE 3-6 Ident

B. ID CODE

The 4096 Identification code, ID code, for the aircraft is displayed in the right hand position of the display, the Ident window. There are eight pushbutton switches (0 through 7) used to select the 4096 ID code.

The ID code may be selected in the Standby, On, and Altitude modes. Three to four seconds after the ID code has been selected or immediately after the "IDT" pushbutton has been pressed the new code is transmitted. The ID code is written into nonvolatile memory so that the code will be saved during power interruptions.

C. VFR (see Figure 3-7)

Momentarily depressing the "VFR" pushbutton causes the pre-programmed VFR code to supersede whatever code was previously entered. The ID code will be immediately displayed and transmitted 4 to 6 seconds later. This ID code will be stored as the last active ID code just as if it were entered from the front panel (see Figure 3-7).

The VFR code is programmed by the following sequence:

- (1) Place the unit in Standby
- (2) Enter in the desired VFR code with the ident code pushbutton switches.
- (3) Depress the "VFR" pushbutton while holding the "IDT" pushbutton in its depressed position.

NOTE

Pressing and holding the "VFR" Pushbutton for two seconds will retrieve the last non-VFR 4096 code.

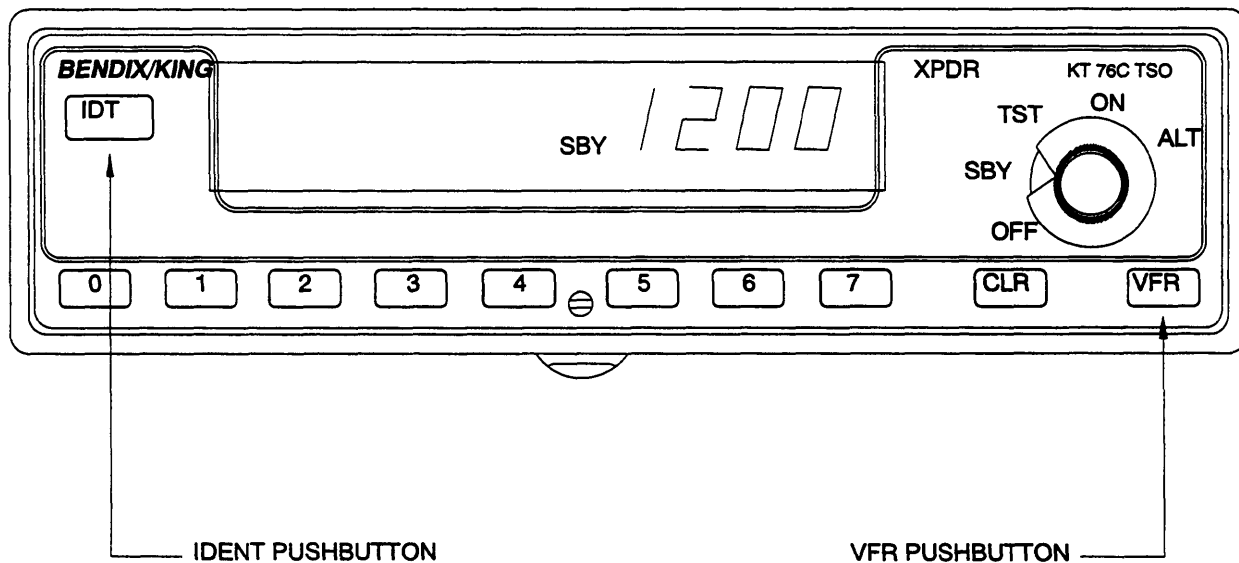

FIGURE 3-7 VFR

D. REPLY

The reply indicator, "R", is illuminated for 750 msec +/- 100 msec when the transponder is replying to a valid interrogation and during the 18 ± 2 seconds following the initiation of an Ident.

E. ALTITUDE DISPLAY

The KT 76C displays the Flight Level altitude on the left side of the display. The display is in hundreds of feet. "FL" is annunciated to indicate Flight Level altitude. Flight Level is a term to indicate that the altitude is not true altitude, but barometric altitude which is not corrected for local pressure. For Example, "FL 040" corresponds to an altitude of 4000 feet, meaning sea level pressure of 29.92 inches of mercury.

The Flight Level altitude is only displayed when the altitude reporting is enabled, i.e. in Altitude mode. The altitude range is -1000 to 62,700 feet. If an invalid code from the altimeter is detected dashes will appear in the altitude window. Altitude reporting is disabled if the altitude window is blank or has dashes (see Figure 3-8).

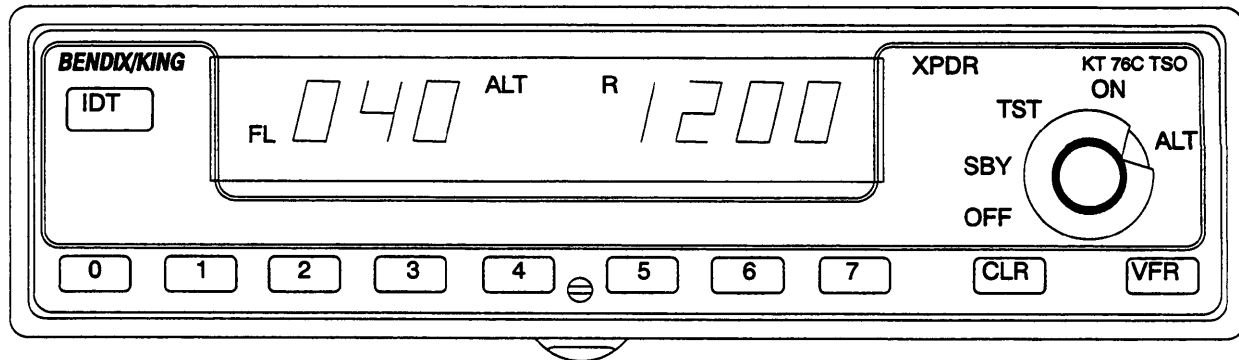

FIGURE 3-8 Altitude Display

F. DISPLAY BRIGHTNESS ADJUSTMENT

(1) Display Adjust

The display has an adjustment to compensate the brightness for different vendors and/or aging of the display. The brightness is adjusted in the test (TST) mode.

To adjust the display brightness, perform the following steps:

- (a) Turn the mode select knob to "TST".
- (b) Press the "O" pushbutton to decrease brightness.

NOTE

Each activation of the O push-button shall decrease the display brightness by ten percent (10%). When no carets are lit beneath the 4096 code, the display is at its dimmest adjust setting.

- (c) Press the 4 push-button to return brightness to the default factory value.
- (d) Press the 7 push-button to increase brightness.

NOTE

Each activation of the 7 push-button shall increase the display brightness by ten percent (10%). When all four carets are lit beneath the 4096 code, the display is at its brightest adjust setting.

- (e) Remove the mode select knob from the "TST" mode to set display parameters.

**TSO APPENDIX E
ENVIRONMENTAL QUALIFICATION FORM**

THIS PAGE RESERVED BLANK

**RTCA DO-160C
ENVIRONMENTAL QUALIFICATION FORM**

NOMENCLATURE: **KT 76C PANEL MOUNTED ATC TRANSPONDER**

PART NUMBER: 066-01156-0101
066-01156-0201

TSO NUMBER: C74c Class 1A

MANUFACTURER'S SPECIFICATION: MPS 004-02048-4000

MANUFACTURER: Honeywell International Inc.

ADDRESS: 23500 West 105th Street
Olathe, Kansas 66061
USA

CONDITIONS	PARAGRAPH	CONDUCTED TESTS
Temperature and Altitude	4.0	Category A1C1 (Temp. -20°C/+55°C, Alt. 35K) (Decomp., 8K to 35K < 15 sec.) (Overpressure, 170 kPa) (Loss of Cooling, Not Applicable)
Temperature Variation	5.0	Category B
Humidity	6.0	Category A
Shock	7.0	7.2 and 7.3
Vibration	8.0	Category BPSMN *
Explosion	9.0	Category X (Not Tested)
Waterproofness	10.0	Category X (Not Tested)
Fluids Susceptibility	11.0	Category X (Not Tested)
Sand and Dust	12.0	Category X (Not Tested)
Fungus	13.0	Category X (Not Tested)
Salt Spray	14.0	Category X (Not Tested)
Magnetic Effect	15.0	Class Z
Power Input	16.0	Category BZ
Voltage Spike Conducted	17.0	Category AB
Audio Frequency Conducted Susceptibility	18.0	Category BZ
Induced Signal Susceptibility	19.0	Category A
Radio Frequency Susceptibility	20.0	Category T
Radio Frequency Emission	21.0	Category Z
Lightning Induced Transient Susceptibility	22.0	Category X (Not Tested)
Lightning Direct Effects	23.0	Category X (Not Tested)
Icing	24.0	Category X (Not Tested)

* Refer to page 2 for vibration resonances.

Honeywell International Inc.
KT 76C Environmental Qualification Form

P/N 004-02048-4800
Revision AA
Page 1 of 3

VIBRATION RESONANCES
(for categories P,S,M,N)

X-AXIS (Hz)	Y-AXIS (Hz)	Z-AXIS (Hz)
395	268	132
458	377	288
498	546	322
874	613	595
	763	621
		1843

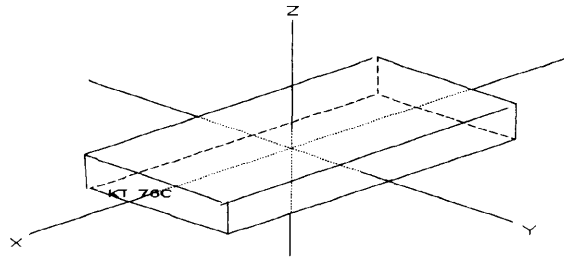

VIBRATION AXIS

- Notes:
1. Critical frequencies did not change during the vibration environment.
 2. There was no changes in the measured performance of the KT 76C during the vibration environment.

Document Revision History

Revision Number	Change Order Number	Date	Remarks
0	N/A	7-96	Initial Release
1	116735	8-96	Add Vibration Categories M and N and Freq. Resonances.
2	116915	8-96	Add Class 1A to TSO C74c. Add Notes 1 and 2.
AA	737279	3-04	Add new flavor 066-01156-0201

THIS PAGE RESERVED BLANK