

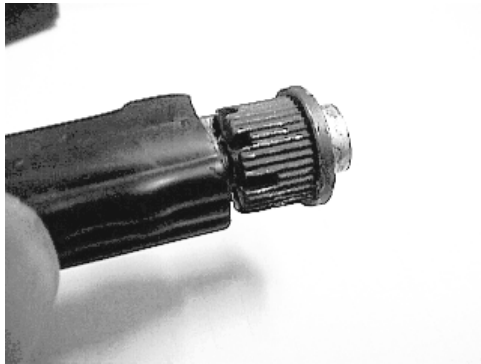

Bob Nuckolls  
 6936 Bainbridge Road  
 Wichita, Kansas 67226-1008  
 Voice/Fax: 316-685-8617  
 E-mail: nuckolls@aeroelectric.com

## Getting the Most out of your crimp tool . . .

**Top View:** This is the business side of your crimp tool. Pins are inserted from the opposite side and gripped gently by the 4 punches which close on the pin as the handles are squeezed. Insert the stripped end of wire into the wire grip barrel of the pin from this side.



**Crimp Adjust:** This knob can be pulled out to disengage locking slots and rotated to size the finished crimp. Rotating clockwise increases size, counter-clockwise decreases size.



**Crimp Dimension Indicator:** Most of the tools we've found have a plastic cover over a slot in the crimper handle. A red bar graph is visible under the window. Markings on the window give dimensions in thousandths of an inch on one side, and an arbitrary numbered scale on the other. For crimping D-sub pins onto 20AWG wire, set for 0.045"; 22AWG is 0.35" and 24AWG gets 0.027". If your tool does not have the plastic window, use numbered drills as a gage to make initial crimp settings. When a machined pin is crimped onto a wire, the resulting crimp should support an 8 lb (gallon milk jug of water) pull without separation. The goal is to use the maximum diameter crimp to do the job . . . over-crimping (too small) weakens the wire and increases probability of breakage from vibration. You may have to sacrifice a few pins to get this setting right.

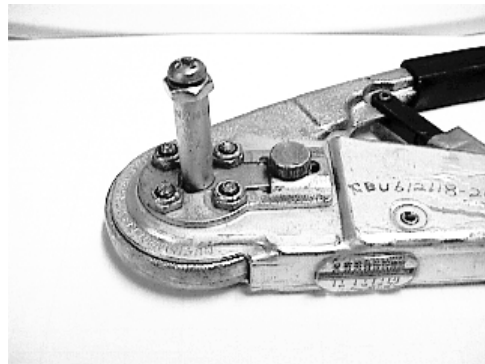
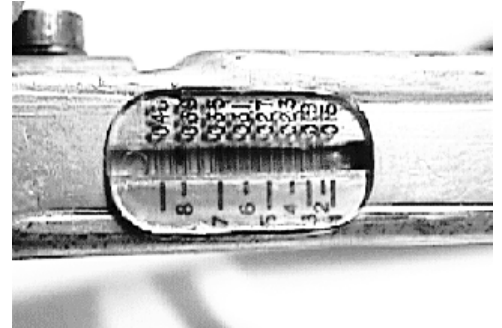

**Home Made Pin Positioner:** Most of the time, I simply-hand position the pin per instructions on the next page. If you have a LOT of pins to put on, it's a bit easier if you can just drop the pin into the front and have it fall into the right position every time. To make a pin positioner, get a piece of 5/16" aluminum, brass or mild steel rod 1.25" long. Chuck in drill press and use the edge of small mill file to cut a groove in the rod so that diameter at the bottom of the groove is .250" and the edge of the groove is .175" from one end. Groove width is not important as long as it's over .06" wide. You may find it easier to make the original stock .1" or so longer than necessary, cut the groove in approxi-

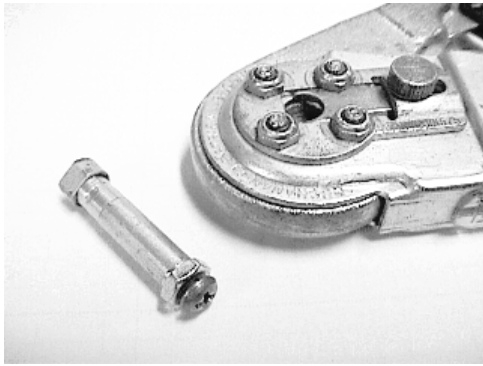

mately, the right place and then cut the rod to finished length so that the .175 dimension is made. Next, chuck the part in your drill press and grab a center drill in a drill press vise so that it sticks straight up. Use the center drill on the under face of the spinning part to find and mark the center of the part. Replace the center drill with a #36 drill and use it to go all the way through the part. Replace the #36 drill with a #26 drill and counter bore the #36 hole to a depth just .15" shorter than the overall length of the part. Tap the small end for 6-32 thread. File flat on large end so that part just drops into D-shaped hole on back side of crimp tool. Thumb screw and sliding fork should engage groove to retain positioner on crimp tool. Use 6-32 screw to set proper depth of stop for pin to be crimped and lock screw in place with jam-nut as shown in figures.

If you know somebody with a small lathe, they can whip this part out pretty quick. It took me three tries and 30 minutes to do it with my ordinary shop tools. Fortunately, the material is cheap! If you do have access to a lathe, you might consider making fixed positioners for each type of pin you install . . . don't drill the hole all the way through. Eliminate the adjustable stop-screw. Replace the #36 drill with one just a few thousandths larger than the o.d. of the pin and control depth of bore to the appropriate value for the pin.

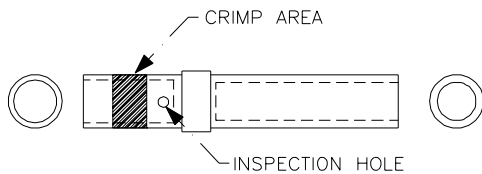
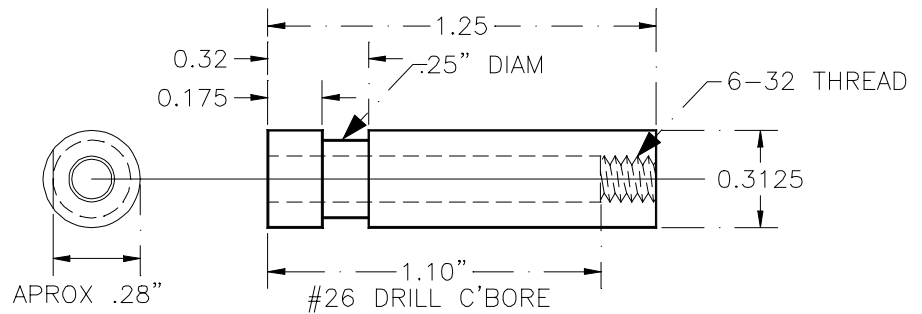

**Installing Pins:** Okay, we're down to the real meat of the matter. This tool is designed to put four calibrated indentations around the wire grip barrel of each pin. The figure to left shows a female pin where I've shaded the crimp area approximately centered on the area between the end of pin and its retention ridge. If you don't build a positioner, simply hand position the pin and grip lightly in the crimp tool while you insert the stripped end of the wire to be terminated. If you have a positioner, adjust the stop screw to center the crimp

in the wire grip area shown. Subsequent installations are easily accomplished by simply dropping a new pin into the positioner from the working side of the tool followed by the end of the prepared wire. Each pin has an inspection hole: check the installed pin for adequate insertion depth of the wire. You should be able to see the strands through this hole after the pin is installed.