

PARTS CATALOG

PC-302-1

LYCOMING

O-235-P2A

AIRCRAFT ENGINES

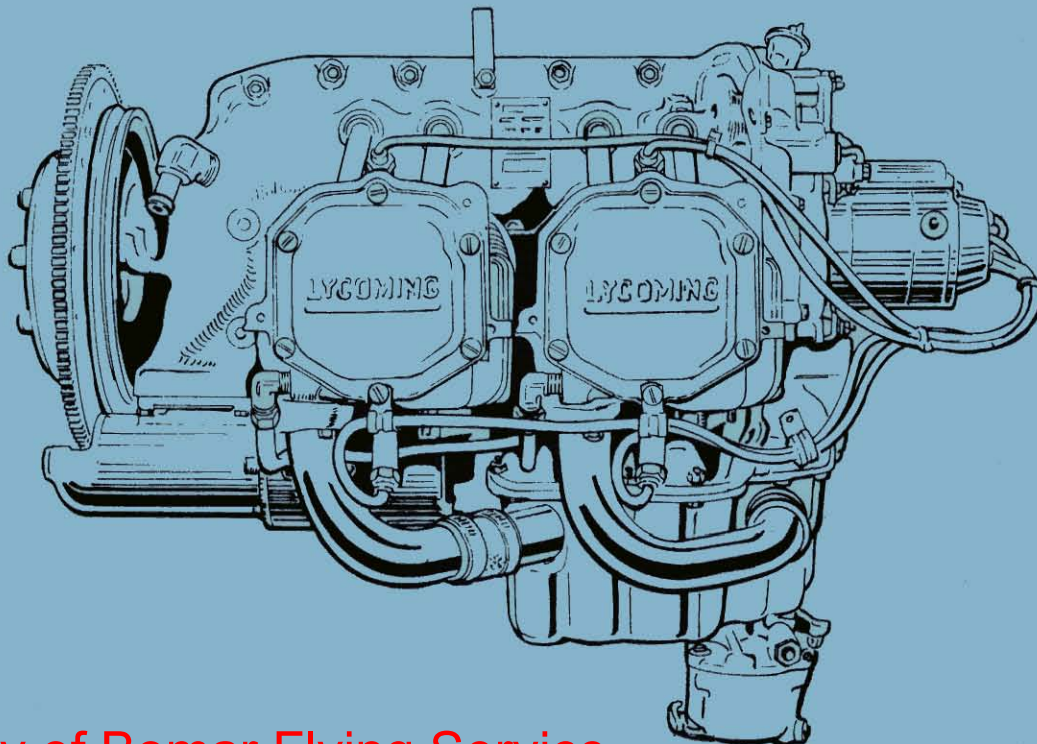

Courtesy of Bomar Flying Service
www.bomar.biz

AUGUST 1985

TEXTRON Lycoming

652 Oliver Street
Williamsport, PA 17701 U.S.A.
717/323-6181

INTRODUCTION

This illustrated parts catalog contains a complete parts listing for the Avco Lycoming O-235-P2A model aircraft engines.

Major assembly and sub-assembly parts of the engines are listed in the Group Assembly sections in the general sequence of engine build up.

A Service Kits section and Oversize and Undersize Parts List are included to aid in ordering parts as necessary during overhaul.

The Numerical Index is provided for convenience in finding parts when only the part number is known.

Parts coverage of Vendor Accessories used on Avco Lycoming engines may be found in the appropriate Vendor's Parts Catalog. A list of these publications appear in the latest edition of Service Letter No. L114.

NOTE

The illustrations, pictures and drawings shown in this publication are typical of the subject matter they portray.

This catalog, when used in conjunction with the appropriate overhaul manual, shall be used for parts identification only. Under no circumstances shall this catalog be used as an assembly or installation document.

Any reference in this document to a suppliers/parts manufacturers' product, by name, trademark, part number or other description is solely for the purposes of identification and does not indicate or infer that Avco Lycoming accepts responsibility for quality control and/or airworthiness of parts which do not pass through the Avco Lycoming quality control system.

SERVICE BULLETINS, INSTRUCTIONS AND LETTERS

Although the information contained in this parts catalog is up-to-date at time of publication, users are urged to keep abreast of later information through all Avco Lycoming distributors or from the factory by subscription. Consult the latest edition of Service Letter No. L114 for subscription information.

HOW TO ORDER PARTS

In ordering parts for your engine, observe the following instructions which will expedite shipment of correct parts required without delay.

- a. Always specify the model and serial number of your engine.
- b. Always specify Part Number, Nomenclature and quantity required.

TABLE OF CONTENTS

SECTION	PAGE
Introduction	i
Table of Contents	ii
Oversize and Undersize Parts List	iii
1. CRANKCASE, CRANKSHAFT AND CAMSHAFT GROUP	
Crankcase Assembly	1-1
Oil Level Gage Assembly	1-3
Crankshaft, Camshaft and Related Parts	1-5
Crankcase Related Parts	1-7
Crankshaft Idler Gears and Tachometer Shaft	1-9
Crankcase Attaching Parts	1-11
2. ACCESSORY HOUSING AND RELATED PARTS	
Accessory Housing Assembly	2-1
Oil Pump Assembly and Accessory Housing Attaching Parts	2-3
Propeller Governor Oil Line	2-5
Propeller Governor Drive and Cover	2-7
Fuel Pump Assembly and Attaching Parts	2-9
Vacuum Pump Drive and Cover	2-10
Oil Filter Assembly and Oil Cooler Bypass Valve	2-11
3. CYLINDER, PISTON AND VALVE TRAIN	
Connecting Rods, Pistons and Ring Assemblies	3-1
Cylinder Assembly	3-3
Cylinder Related Parts	3-5
Valve Assembly	3-7
Cylinder Head Drain Tubes and Intercylinder Cooling Baffles	3-9
4. IGNITION SYSTEM	
Magnetos, Drives, Harnesses and Spark Plugs	4-1
5. ELECTRICAL COMPONENTS	
Starter Motor and Attaching Parts	5-1
6. OIL SUMP AND INDUCTION SYSTEM	
Oil Sump Assembly and Oil Suction Screen	6-1
Intake Pipe Assembly	6-3
Carburetor Assembly	6-5
Priming System	6-7
7. SERVICE KIT SECTION	
Seal and Gasket Set	7-1
Cylinder, Piston and Ring Assembly	7-2
8. NUMERICAL INDEX	8-1

Oversize and Undersize Parts Listing

PART NO.	DESCRIPTION	OVERSIZE								UNDERSIZE		
		P02 .002	P05 .005	P10 .010	P15 .015	P20 .020	P30 .030	P40 .040	P50 .050	M03 .003	M06 .006	M10 .010
60814	BUSHING		X	X	X	X						
61681	GUIDE		X	X		X	X	X				
66796	INSERT			X								
68763	BEARING									X	X	X
69373	BEARING			X						X	X	X
69796	DOWEL		X									
73757	BUSHING		X	X	X	X						
LW-11626	GUIDE		X	X		X	X	X				
LW-11900	SEAT			X		X	X					
LW-13792	SEAL								X			
LW-13884	BEARING				X					X	X	X
LW-16699	SEAT			X		X	X					
STD-1065	DOWEL	X	X	X	X							

In addition to the above, studs are available in P01, P02, P03, P05, P07, P10 & P12.

NOTE

When ordering oversize and undersize parts, be sure to specify the required oversize and undersize dimension along with the proper part number. For example, to order bearing LW-13884 in .003 undersize, order part number LW-13884-M3. Oversize code letter is "P" while undersize code letter is "M". These letters are then followed by the number designating the size in thousandths of an inch.

CRANKCASE, CRANKSHAFT AND CAMSHAFT GROUP
CRANKCASE ASSEMBLY

FIG. REF. 1	PART NUMBER	DESCRIPTION	QUANTITY PER ASSEMBLY
1	LW-16354*	CRANKCASE ASSEMBLY	1
2	STD-557	DOWEL, 1/2 dia. x 19/32 long, hollow	2
3	LW-11623	STUD, 7/16-20 x 10-7/16 long	2
4	LW-11622	STUD, 7/16-14 x 9-25/32 long	4
5	44-13	STUD, 7/16-14 x 1-5/8 long	8
6	38-13	STUD, 3/8-16 x 1-5/8 long	16
7	1102	PLUG, 1/8-27 NPT, Allen	3
8	STD-514	DOWEL, 5/16 dia. x 1/2 long	2
9	69796	DOWEL, Crankshaft bearing	2
10	STD-111	ELBOW, 3/4 pipe & hose (90°)	1
11	31C-12	STUD, 5/16-18 x 1-1/2 long	4

* Used with variable pitch prop.

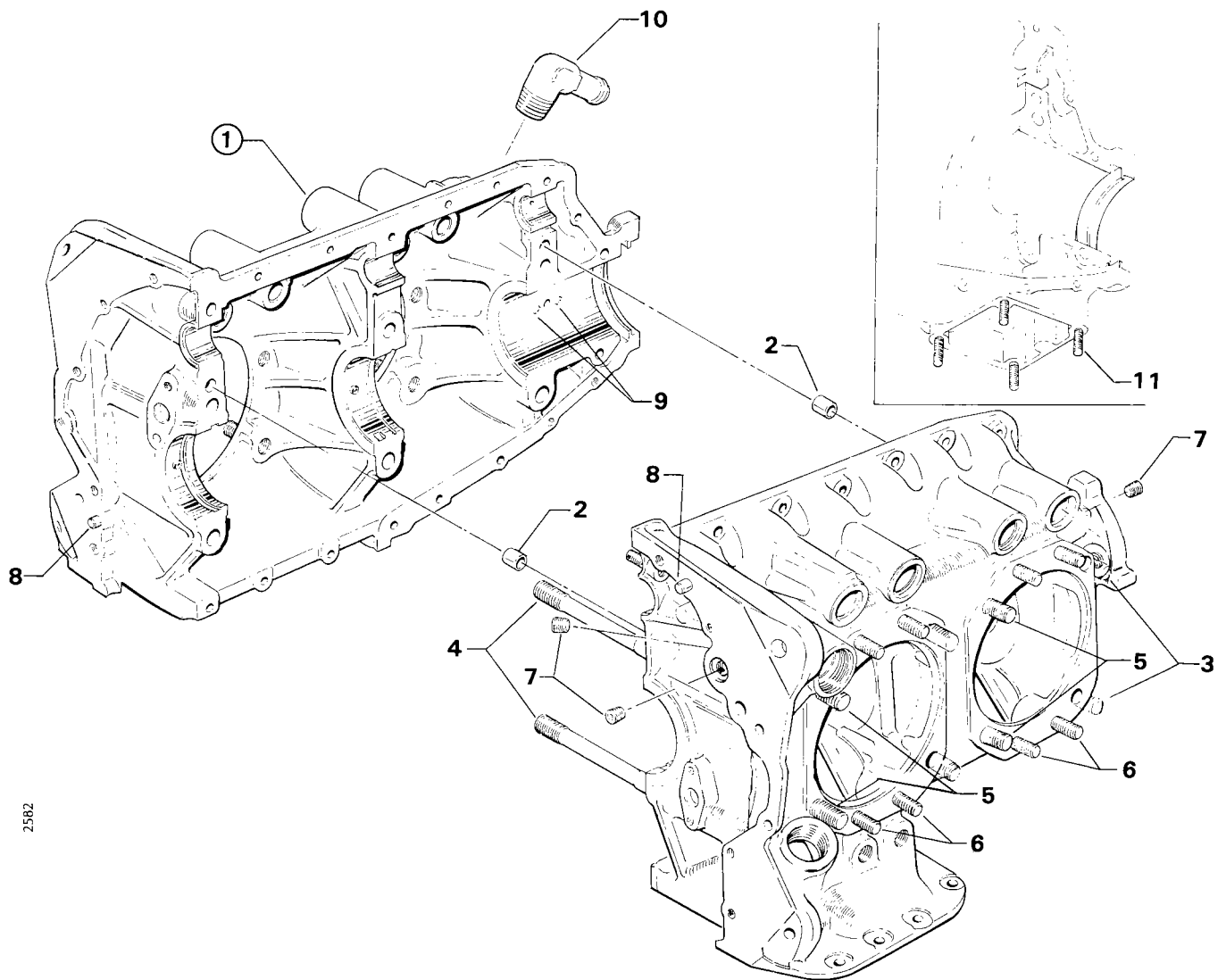

2582

Figure 1. CRANKCASE ASSEMBLY

LYCOMING

O-235-P2A PARTS CATALOG

CRANKCASE, CRANKSHAFT AND CAMSHAFT GROUP OIL LEVEL GAGE ASSEMBLY

FIG. REF. 2	PART NUMBER	DESCRIPTION	QUANTITY PER ASSEMBLY
1	75767	TUBE, Oil level gage	1
2	72059	GASKET, Oil level gage	1
3	74065	RING, Oil level gage seal	1
4	LW-14781	GAGE ASSY., Oil level	1
5	72844	PLUG, Oil level gage	1

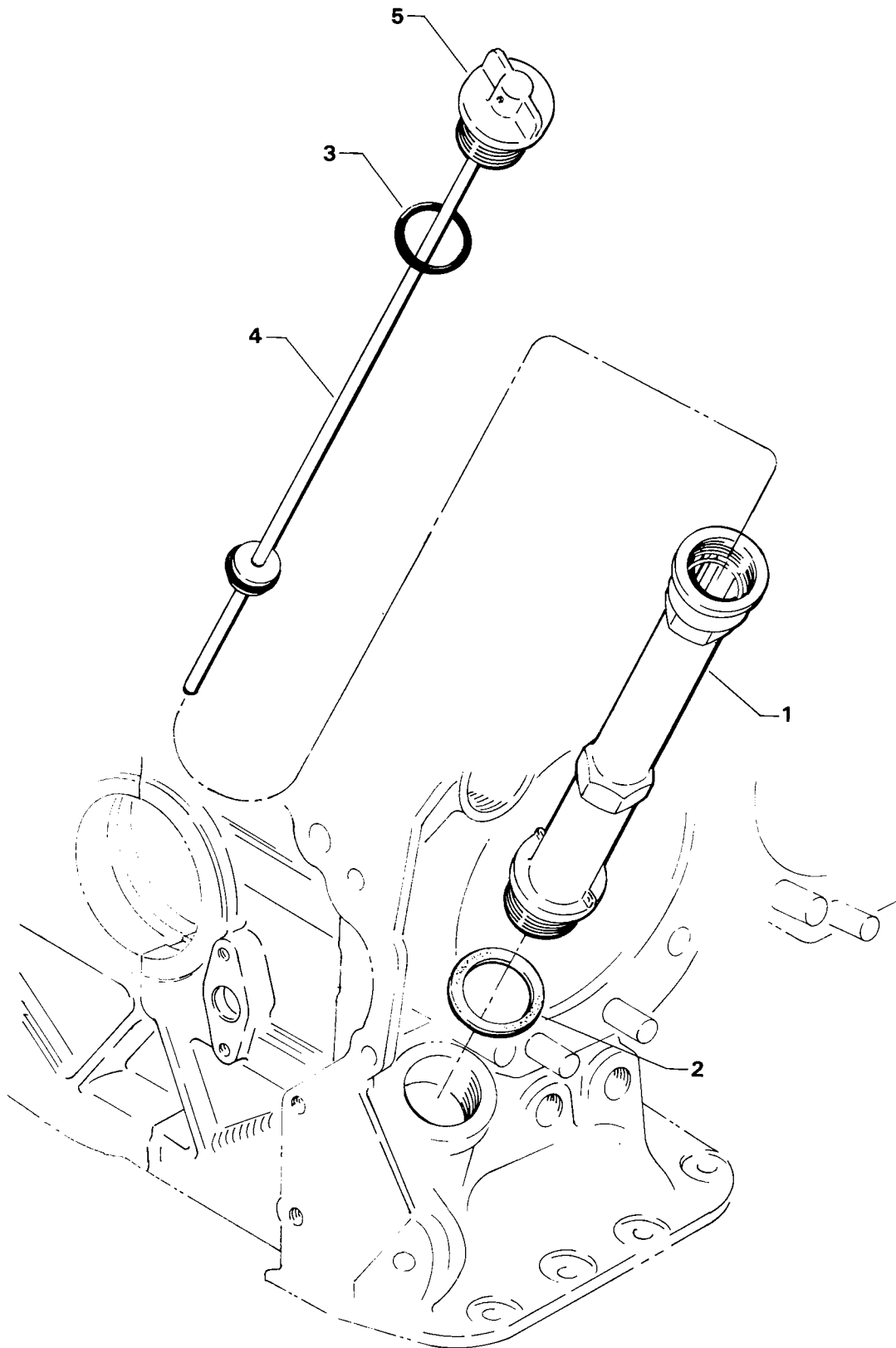

2583

Figure 2. OIL LEVEL GAGE ASSEMBLY

LYCOMING

O-235-P2A PARTS CATALOG

CRANKCASE, CRANKSHAFT AND CAMSHAFT GROUP CRANKSHAFT, CAMSHAFT AND RELATED PARTS

FIG. REF. 3	PART NUMBER	DESCRIPTION	QUANTITY PER ASSEMBLY
1	LW-12695*	CRANKSHAFT ASSEMBLY	1
2	STD-1211	PLUG, 2.00 dia. expansion	1
3	STD-1065	DOWEL, Stepped, 19/64 x 1/4 dia. x 35/64 long	1
4	61510	PLUG, 1-3/4 O.D.	1
5	73757	BUSHING, Propeller flange (index)	1
6	60814	BUSHING, Propeller	5
7	75706	CAMSHAFT	1
8	61155	GEAR, Crankshaft	1
9	LW-18639	LOCKPLATE, Crankshaft gear	1
10	STD-2213	SCREW, 5/16-24 x 1.00 long	1
11	LW-13675	SUPPORT ASSY., Starter ring gear, 10/12 pitch 3.25:1 drive	1
12	60882	GEAR, Starter ring, 10/12 pitch	1

* Used with variable pitch prop.

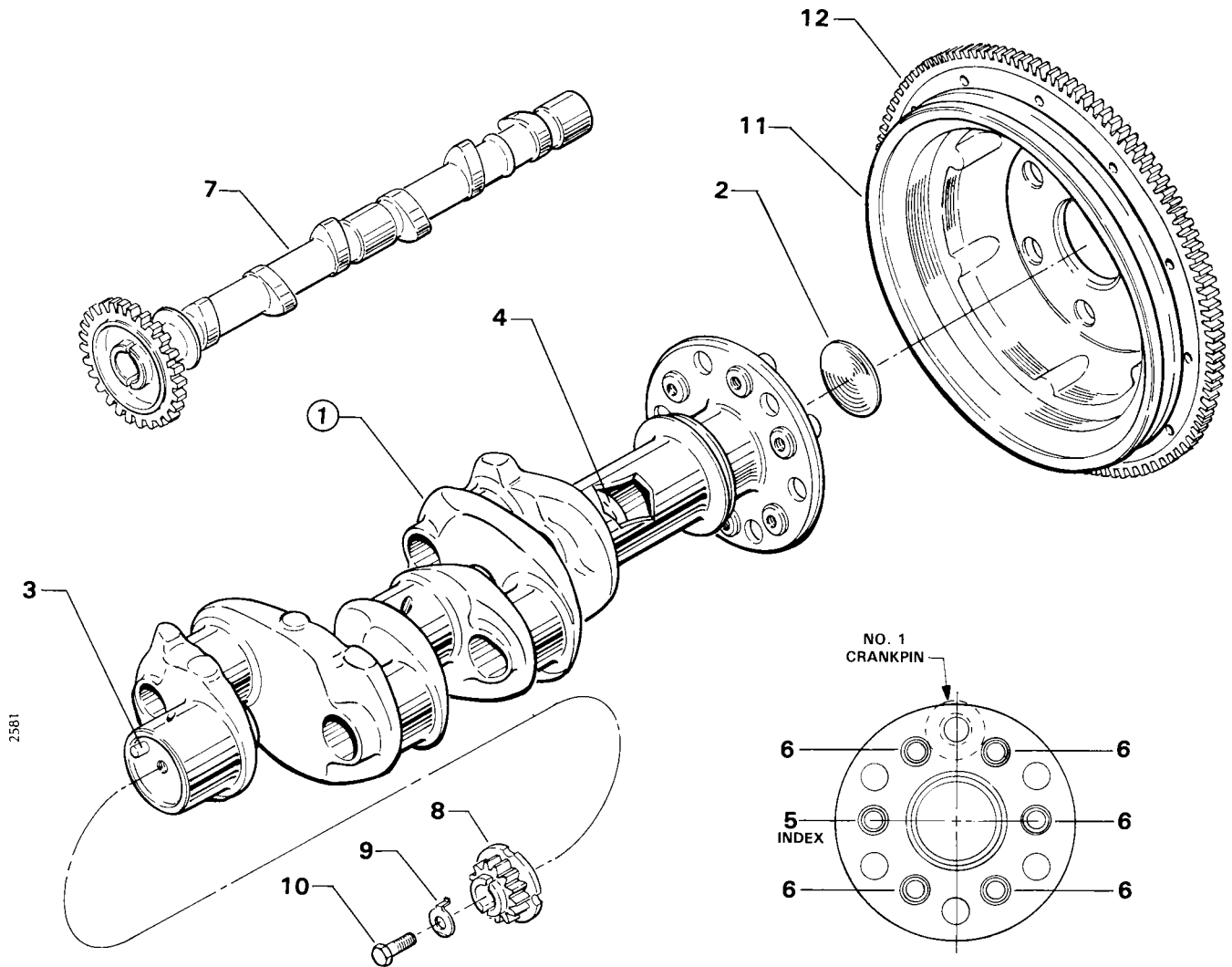

Figure 3. CRANKSHAFT, CAMSHAFT AND RELATED PARTS

LYCOMING

O-235-P2A PARTS CATALOG

CRANKCASE, CRANKSHAFT AND CAMSHAFT GROUP CRANKCASE RELATED PARTS

FIG. REF. 4	PART NUMBER	DESCRIPTION	QUANTITY PER ASSEMBLY
1	1028B	BALL, 11/16 dia.	1
2	61084	SPRING, Oil pressure relief valve	1
3	STD-425	WASHER, No. 10 plain (max. 9)	AR
4	STD-1045	GASKET, 1-1/4 I.D. x 1-1/2 O.D. x 3/32 annular	1
5	76529	PLUG, Oil relief valve	1
6	68763*	BEARING, Crankshaft (use in pairs)	4
7	LW-13884*	BEARING, Crankshaft, front	2
8	LW-13792	SEAL, Crankshaft oil	1
9	72091	RING, Oil seal 23/64 I.D. x 7/64 dia. section	8
10	71105	BODY, Tappet	8

* Used with variable pitch prop.

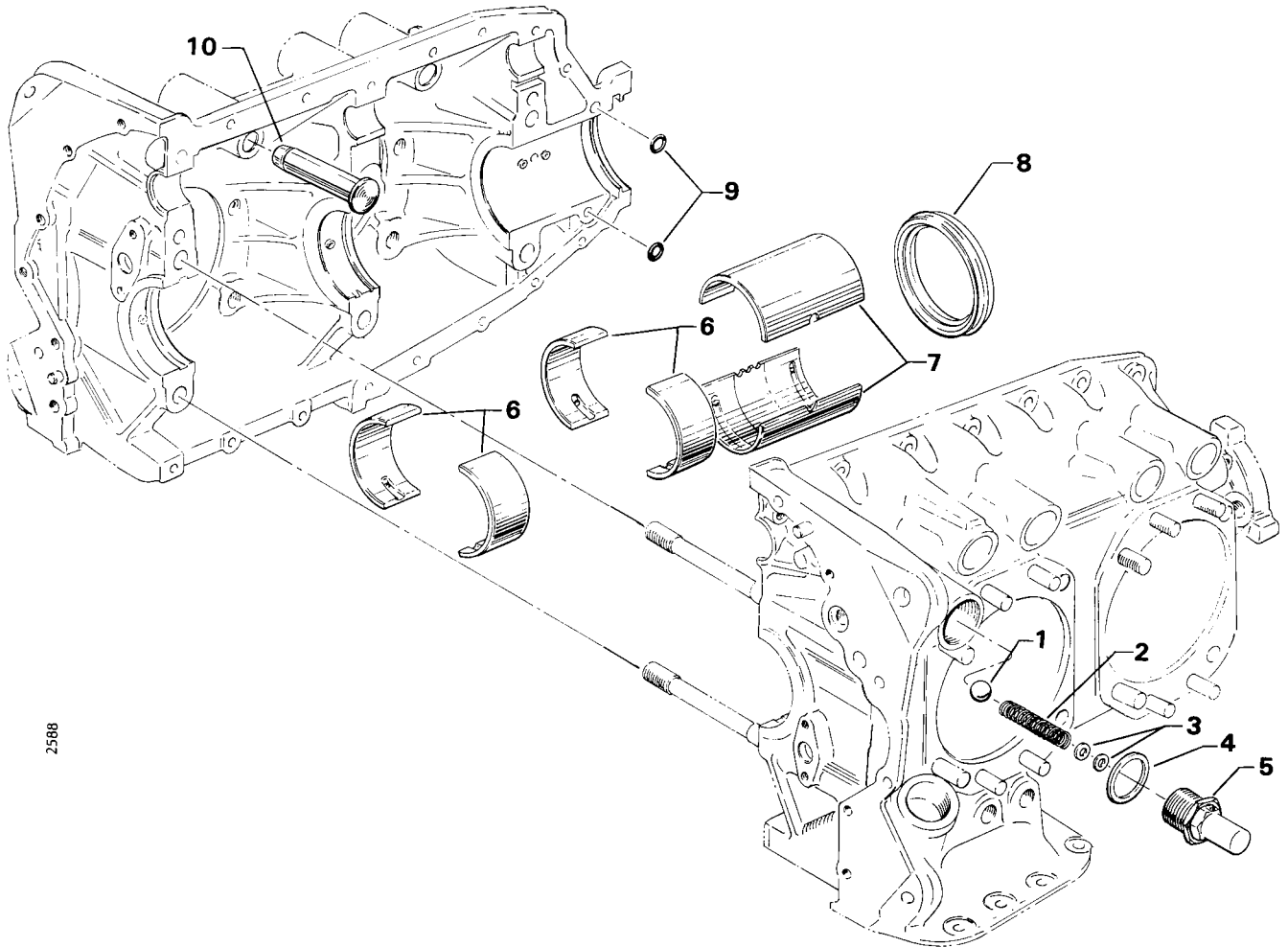

2588

Figure 4. CRANKCASE RELATED PARTS

LYCOMING

O-235-P2A PARTS CATALOG

CRANKCASE, CRANKSHAFT AND CAMSHAFT GROUP CRANKSHAFT IDLER GEARS AND TACHOMETER SHAFT

FIG. REF. 5	PART NUMBER	DESCRIPTION	QUANTITY PER ASSEMBLY
1	61544	PLUNGER, Fuel pump, long	1
2	74996	GEAR ASSY., Crankshaft idler	1
3	77309	BUSHING, Crankshaft idler gear	1
4	75072	GEAR ASSY., Crankshaft idler	1
5	77309	BUSHING, Crankshaft idler gear	1
6	75708	SHAFT ASSY., Tachometer	1
7	LW-18667	PIN, 3/16 x 2-5/16 long	1
8	45530	RING, Oil pump shaft retaining	1
9	61151	SHAFT, Crankshaft idler gear	2
10	73817	LOCKPLATE, 1/4 bolt, 1-3/4 spacing	2
11	STD-705	BOLT, 1/4-20 x 11/16 long	4

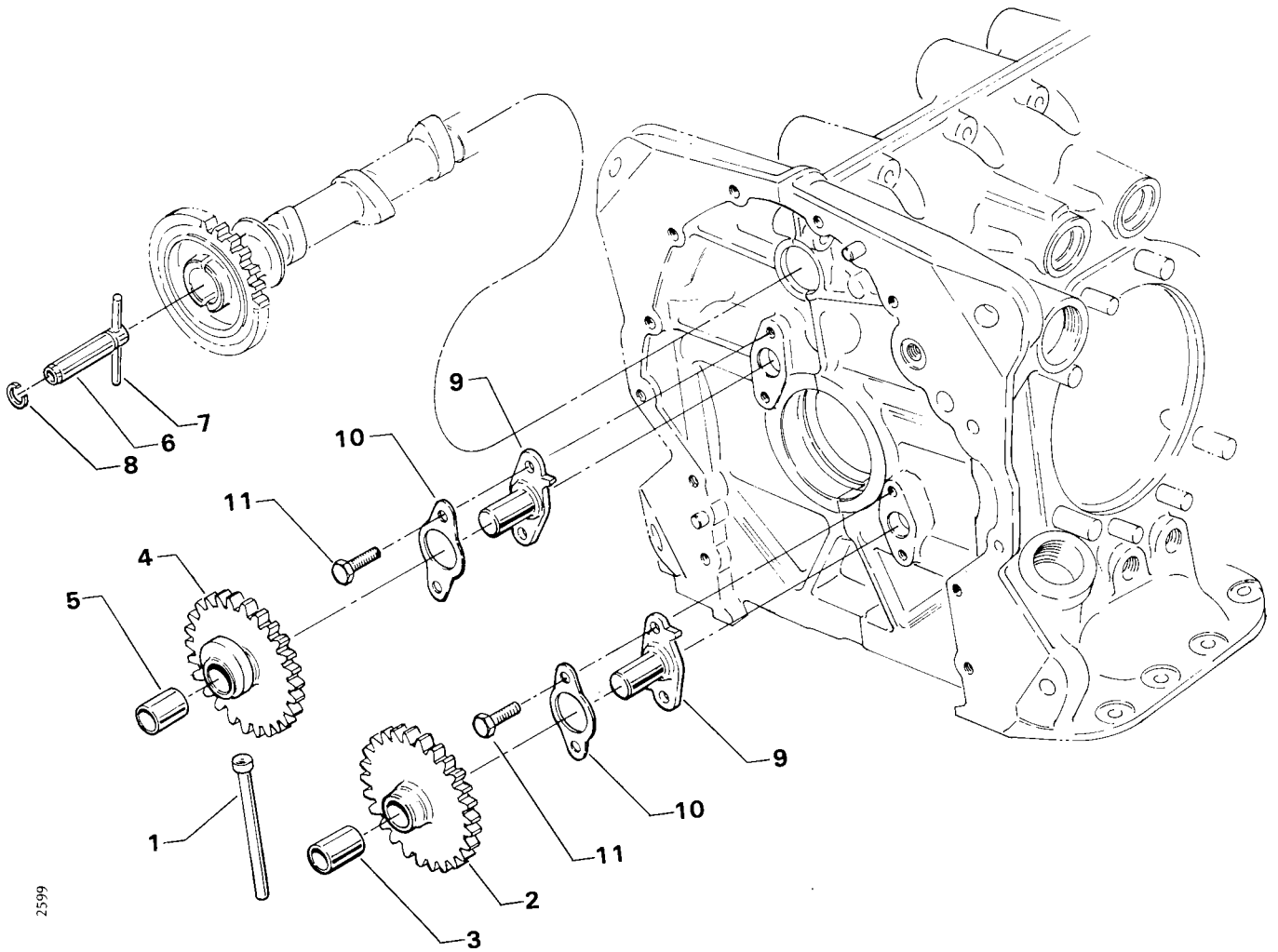

Figure 5. CRANKSHAFT IDLER GEARS AND TACHOMETER SHAFT

LYCOMING

O-235-P2A PARTS CATALOG

CRANKCASE, CRANKSHAFT AND CAMSHAFT GROUP CRANKCASE ATTACHING PARTS

FIG. REF. 6	PART NUMBER	DESCRIPTION	QUANTITY PER ASSEMBLY
1	LW-25-1.50	BOLT, 1/4-20 x 1-1/2 long, hex. head	8
2	STD-8	WASHER, 1/4 plain	16
3	60803	STRAP, Lifting	1
4	LW-25-1.75	BOLT, 1/4-20 x 1-3/4 long, hex. head	1
5	AN6-21	BOLT, 3/8-24 x 13/64 long, hex. head drive	1
6	STD-160	WASHER, 1/4 lock, internal lock	9
7	STD-1411	NUT, 1/4-20 plain	9
8	LW-25S1.50	BOLT, 1/4-20 x 1-1/2 long, dr. end	3
9	STD-8	WASHER, 1/4 plain (Max. 9)	AR
10	STD-1409	NUT, 1/4-20 slotted shear	3
11	STD-33	WASHER, 3/8 plain	2
12	STD-872	NUT, 3/8-24, slotted	1
13	AN6-34A	BOLT, 3/8-24 x 37/64 long, hex. hd.	2
14	STD-33	WASHER, 3/8 plain	4
15	STD-678	WASHER, 3/8 lock, internal teeth	2
16	STD-596	NUT, 3/8-24 plain	2

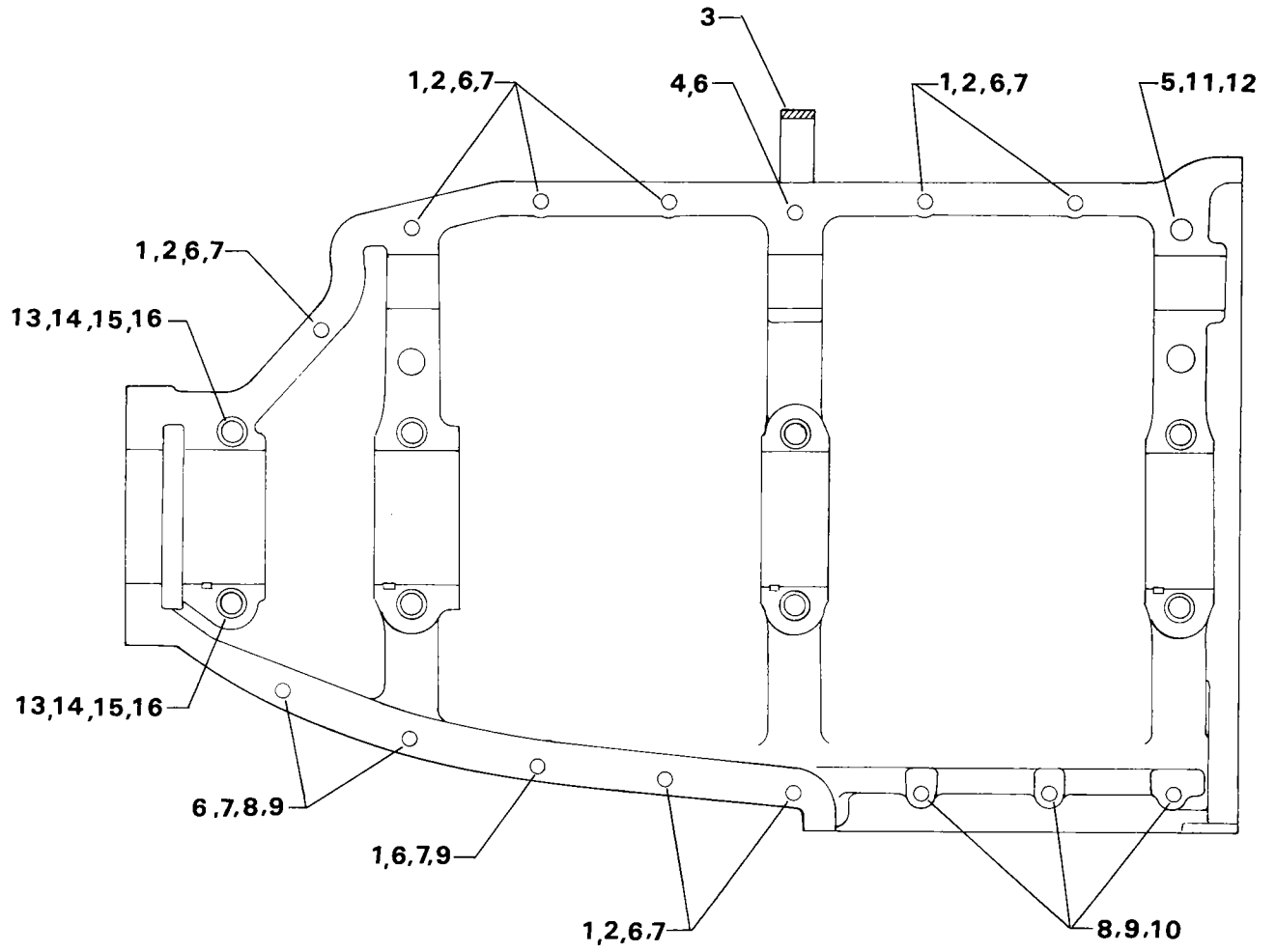

2662

Figure 6. CRANKCASE ATTACHING PARTS

LYCOMING

O-235-P2A PARTS CATALOG

ACCESSORY HOUSING AND RELATED PARTS ACCESSORY HOUSING ASSEMBLY

FIG. REF. 7	PART NUMBER	DESCRIPTION	QUANTITY PER ASSEMBLY
1	73818	GASKET, Accessory housing	1
2	LW-12044	HOUSING ASSEMBLY, Accessory	1
3	31C-12	STUD, 5/16-18 x 1-1/2 long	6
4	31C-19	STUD, 5/16-18 x 2-3/8 long	2
5	31CD-17	STUD, 5/16-18 x 2-1/8 long, drilled	3
6	1102	PLUG, 1/8-27 NPT	2
7	61175	ADAPTER, Tachometer	1
8	STD-783	PLUG, 1/4-28 NPT, Allen	1
9	61400	STUD, 1/4-20 x 1-3/16 long	2
10	25C-22	STUD, 1/4-20 x 2-3/4 long	4
11	STD-784	PLUG, 3/8-18 NPT, Allen	1

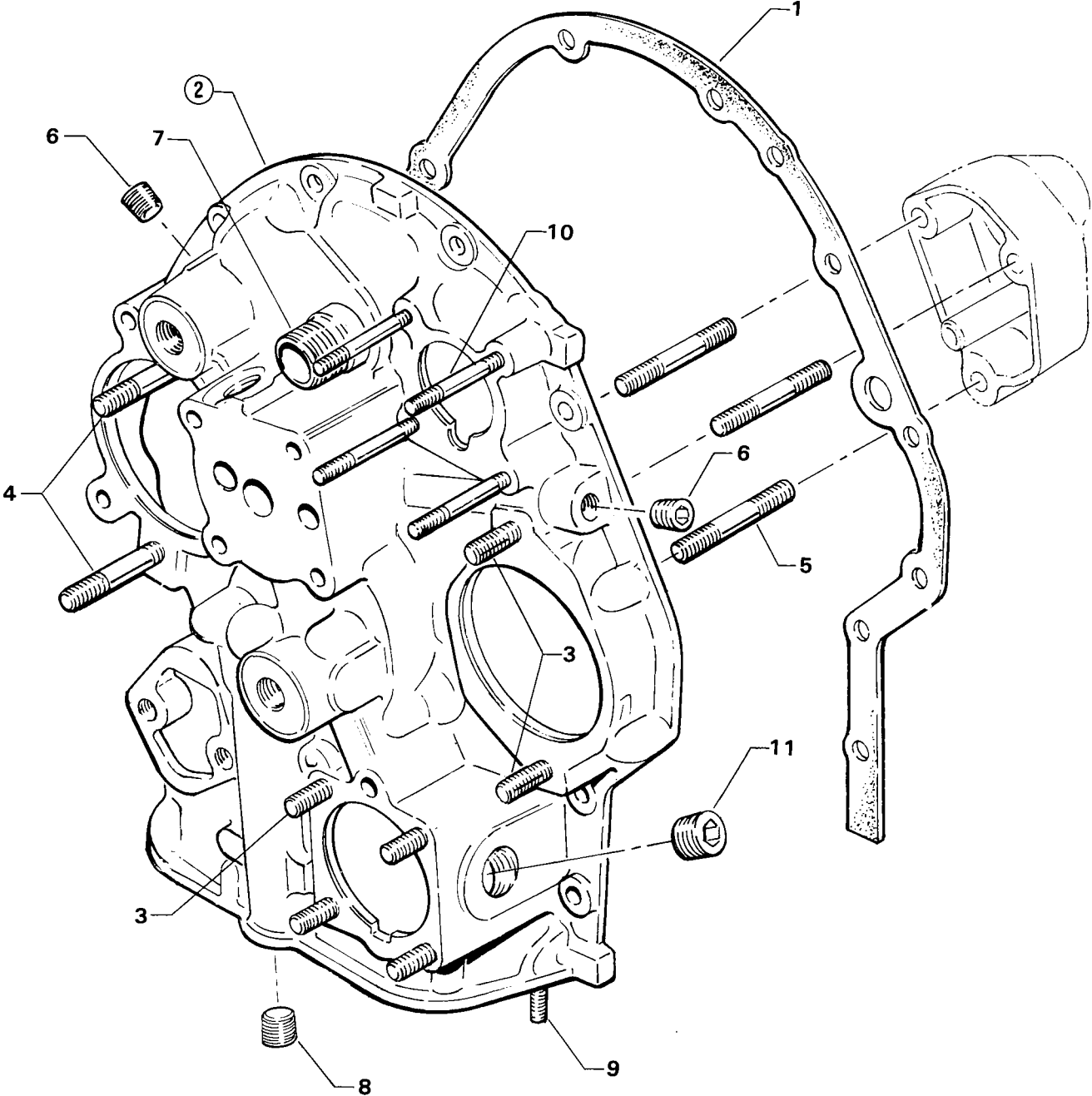

3032

Figure 7. ACCESSORY HOUSING ASSEMBLY

LYCOMING

O-235-P2A PARTS CATALOG

ACCESSORY HOUSING AND RELATED PARTS OIL PUMP ASSEMBLY AND ACCESSORY HOUSING ATTACHING PARTS

FIG. REF. 8	PART NUMBER	DESCRIPTION	QUANTITY PER ASSEMBLY
1	78531	BODY ASSY., Oil pump	1
2	LW-18110	IMPELLER ASSY., Oil pump driven	1
3	61174	SHAFT, Oil pump driven	1
4	LW-18109	IMPELLER, Oil pump driving	1
5	STD-35	WASHER, 5/16 plain	1
6	STD-1420	NUT, 5/16-18 slotted	3
7	LW-14260	SEAL, Tachometer drive, oil	1
8	STD-8	WASHER, 1/4 plain	13
9	STD-160	WASHER, 1/4 lock, internal teeth	12
10	LW-25-2.00	BOLT, 1/4-20 x 2.00 long, hex. head	2
11	LW-25-0.94	BOLT, 1/4-20 x 15/16 long, hex. head	10
12	STD-1411	NUT, 1/4-20 plain	2

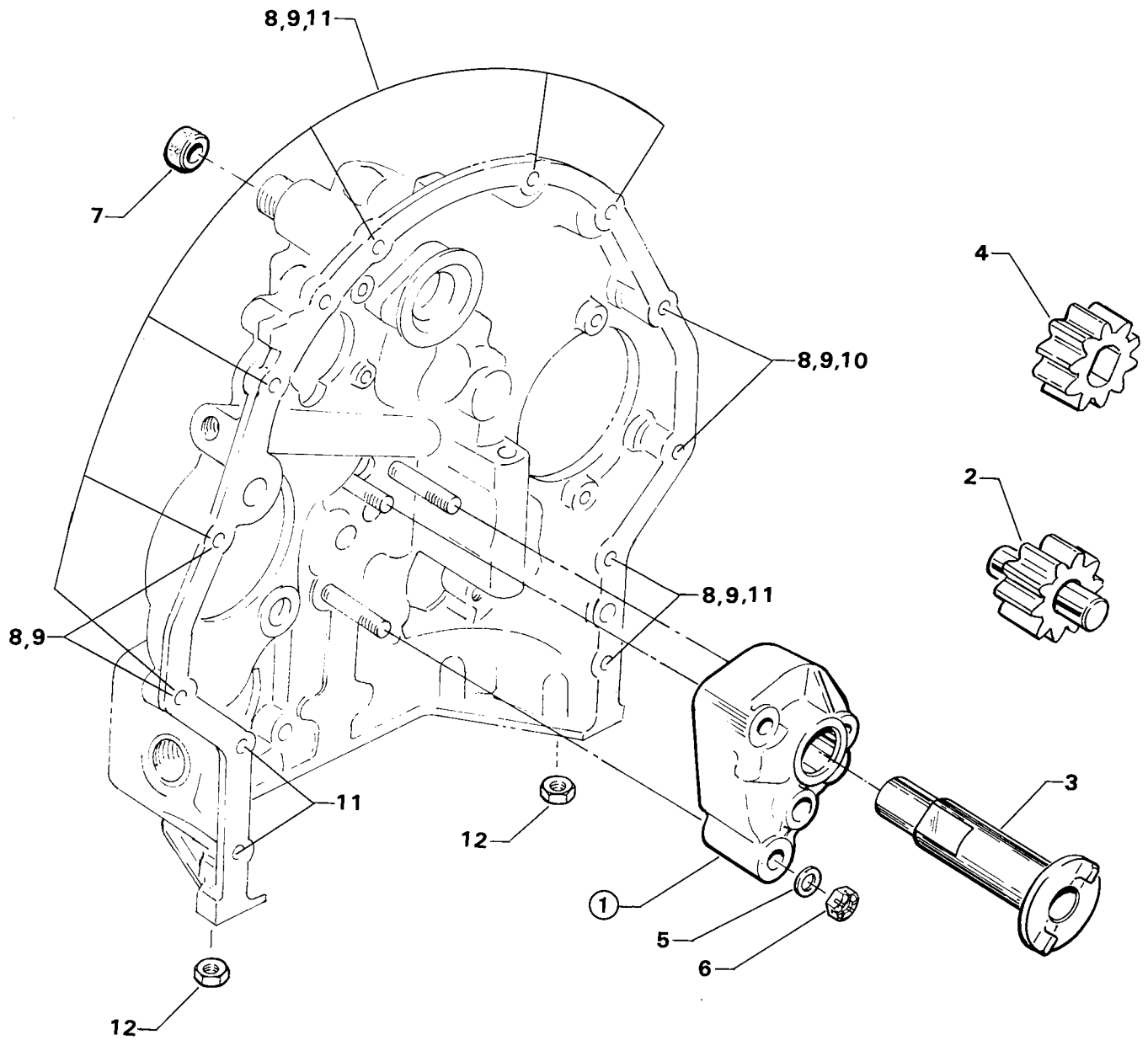

3033

Figure 8. OIL PUMP ASSEMBLY AND ACCESSORY HOUSING ATTACHING PARTS

ACCESSORY HOUSING AND RELATED PARTS
PROPELLER GOVERNOR OIL LINE

FIG. REF. 9	PART NUMBER	DESCRIPTION	QUANTITY PER ASSEMBLY
1	75167	TUBE ASSY., Prop. governor oil line	1
2	STD-1930	HOSE, 3/8 I.D. x 1.00 long	1
3	75165	CLIP, Prop. governor oil line support	1
4	STD-35	WASHER, 5/16 plain	3
5	STD-475	WASHER, 5/16 lock, internal teeth	1
6	STD-1838	BOLT, 5/16-18 x 15/16 long, hex. hd.	1
7	LW-16266-25-38	CLAMP	1
8	MS20822-6*	ELBOW, 3/8 flared tube & 1/4 NPT, 90°	1
9	74070**	ELBOW, 3/8 flared tube & 9/16-18 str. thd., adj. 45°	1
10	MS29512-06	“O” RING	1

* Assemble in right crankcase, front.
** Assemble in prop. governor adapter.

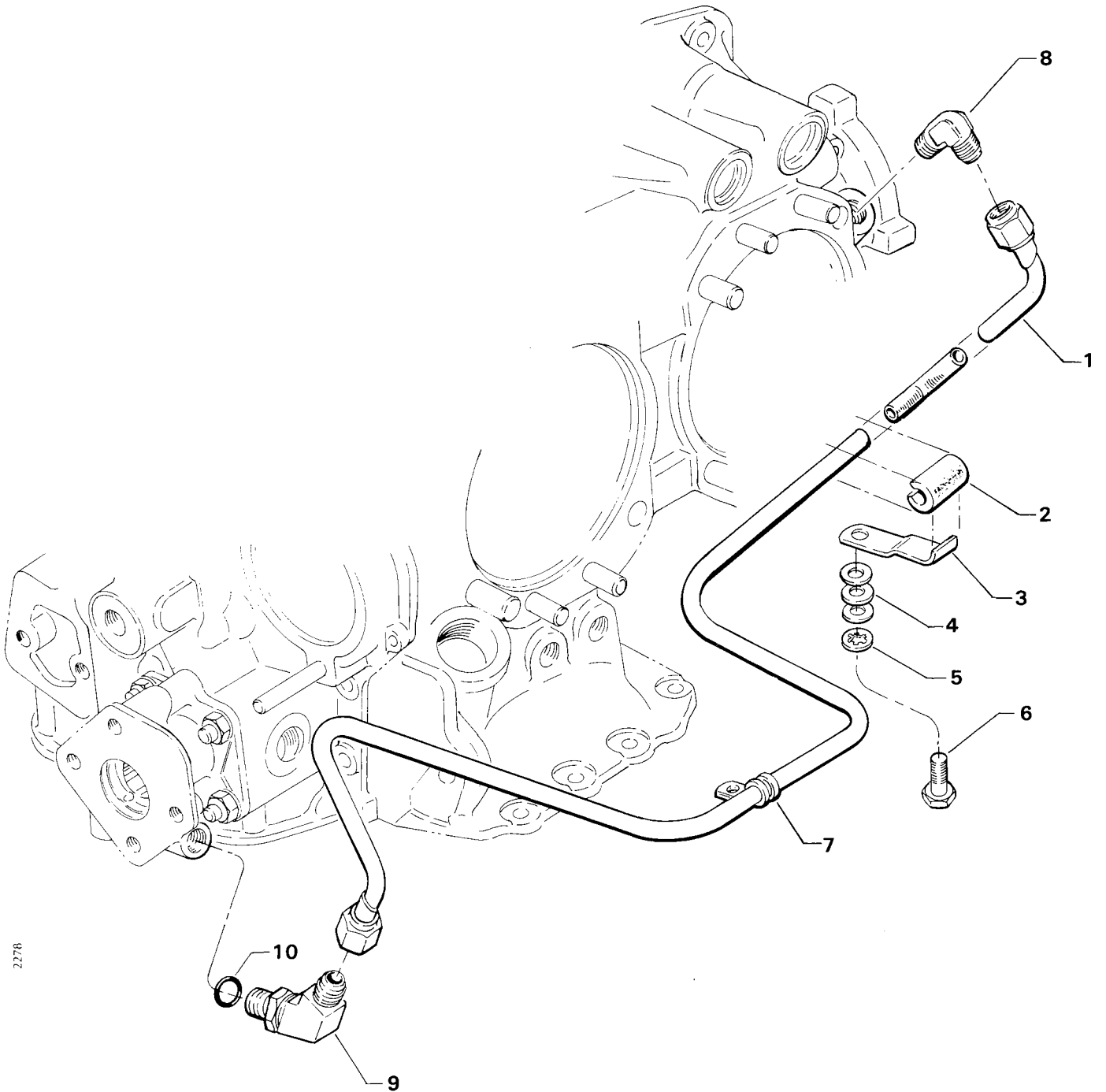

Figure 9. PROPELLER GOVERNOR OIL LINE

LYCOMING

O-235-P2A PARTS CATALOG

ACCESSORY HOUSING AND RELATED PARTS PROPELLER GOVERNOR DRIVE AND COVER

FIG. REF. 10	PART NUMBER	DESCRIPTION	QUANTITY PER ASSEMBLY
1	68317	SHAFTGEAR, Prop. governor drive	1
2	71596	WASHER, Accessory driven gear	1
3	STD-1221	RING, 13/16 dia. x 3/64 thick, internal retaining	1
4	68315	GASKET, Accessory drive adapter	1
5	75153	ADAPTER ASSY., Prop. governor drive	1
6	1102	PLUG, 1/8-27 NPT, Allen	1
7	31C-16	STUD, 5/16-18 x 2.00 long	4
8	STD-1774	PIN, 1/8 x 1/4 long	1
9	STD-35	WASHER, 5/16 plain	4
10	STD-475	WASHER, 5/16 internal lock	4
11	STD-1410	NUT, 5/16-18 plain	4
12	72053	GASKET, Governor	1
13	72378	COVER, Governor drive	1
14	STD-35*	WASHER, 5/16 plain	AR
15	STD-475	WASHER, 5/16 internal lock	4
16	STD-1410	NUT, 5/16 plain	4

* 32 required for Woodward governor; 4 required for AN governor.

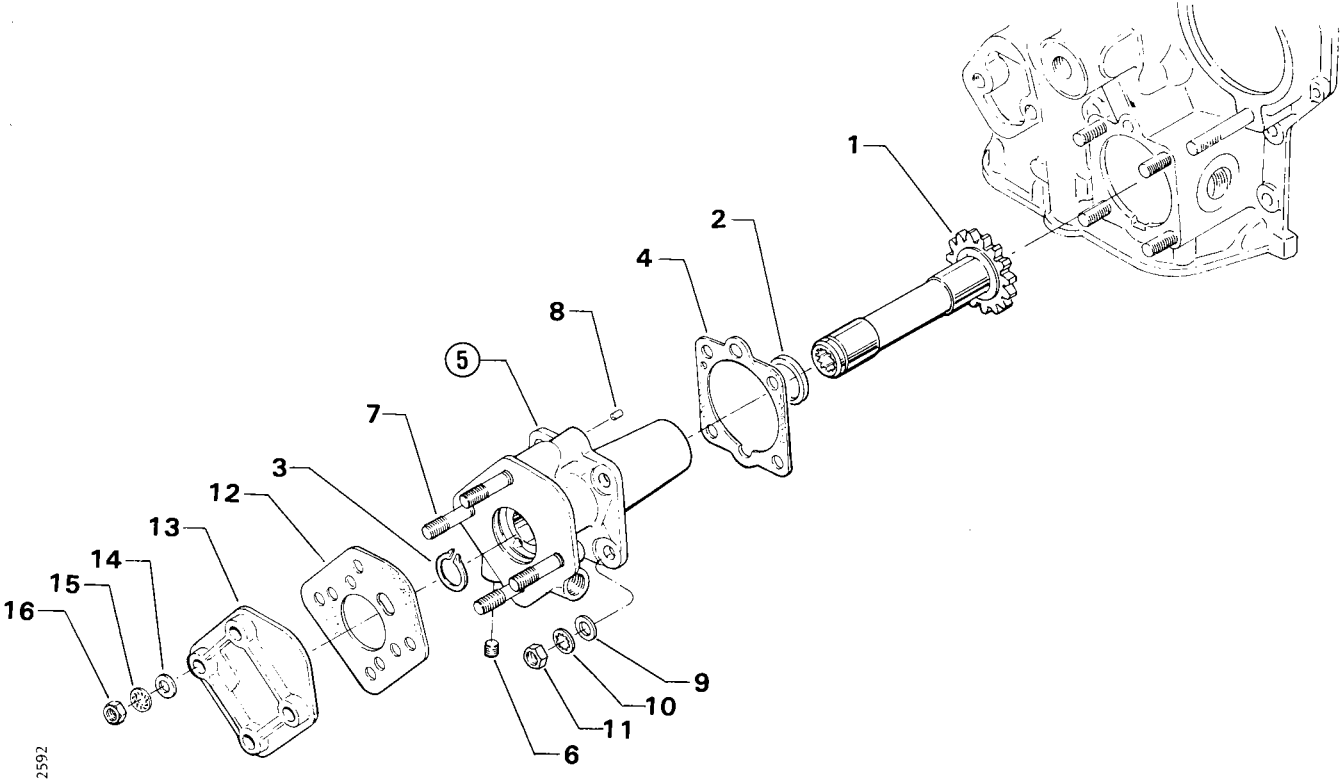
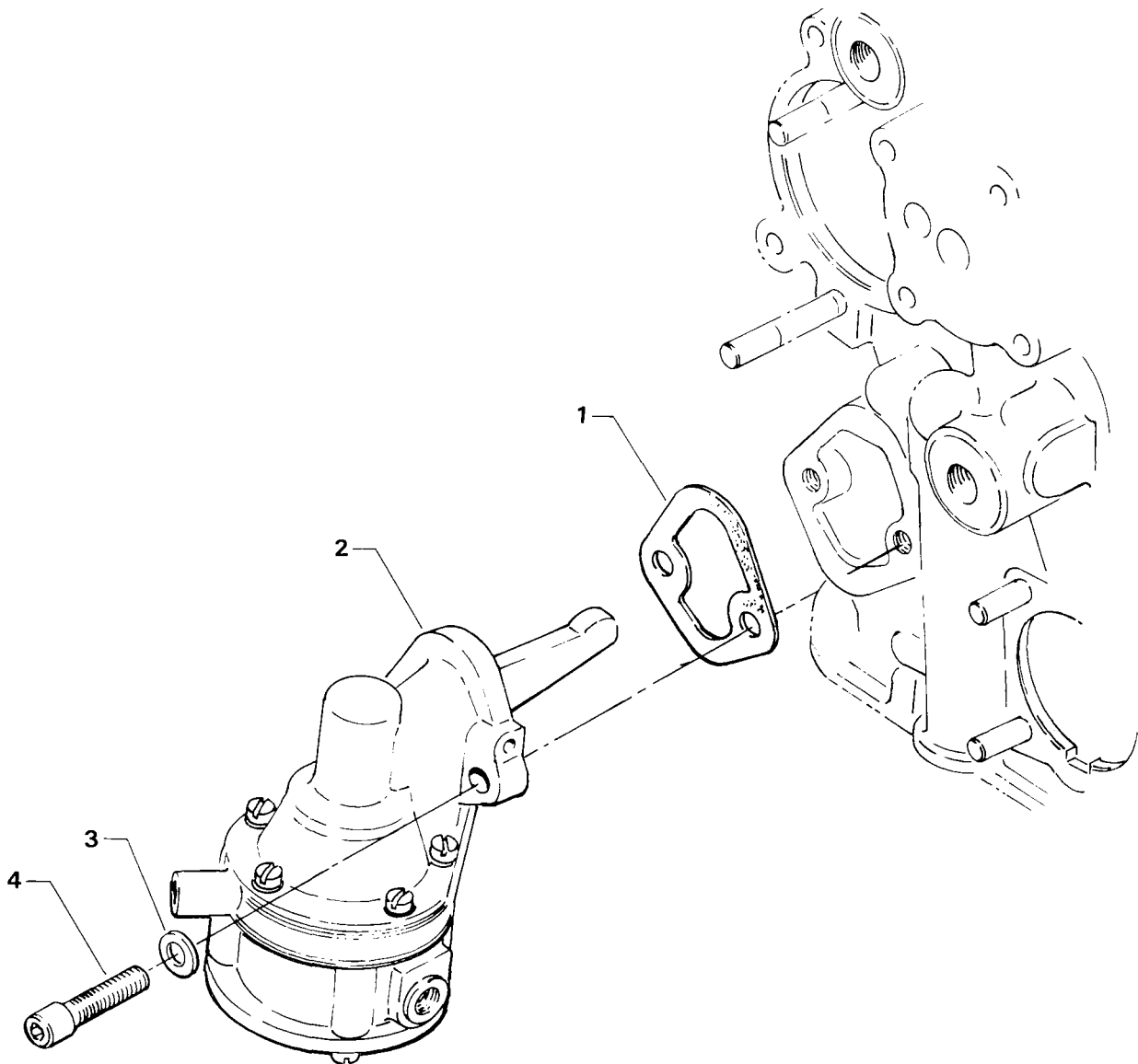

Figure 10. PROPELLER GOVERNOR DRIVE AND COVER

ACCESSORY HOUSING AND RELATED PARTS
 FUEL PUMP ASSEMBLY AND ATTACHING PARTS

FIG. REF. 11	PART NUMBER	DESCRIPTION	QUANTITY PER ASSEMBLY
1	60096	GASKET, Fuel pump	1
2	LW-15472	FUEL PUMP, Low pressure, dual diaphragm (6441271)	1
3	STD-33	WASHER, 3/8 plain	2
4	STD-1882	SCREW, 3/8-16 x 1-9/32 long, socket head, dr. hd.	2



10134

Figure 11. FUEL PUMP ASSEMBLY AND ATTACHING PARTS

ACCESSORY HOUSING AND RELATED PARTS
VACUUM PUMP DRIVE AND COVER

FIG. REF. 12	PART NUMBER	DESCRIPTION	QUANTITY PER ASSEMBLY
1	61183	GASKET, Accessory adapter	1
2	61098	ADAPTER ASSY., Vacuum pump	1
3	STD-1774	PIN, 1/8 dia. x 1/4 long	1
4	STD-2217	SEAL, Oil, 7/8 I.D. x 1-1/2 O.D. x 5/16 wide	1
5	72970	GEAR ASSY., Vacuum pump driven	1
6	71596	WASHER, Accessory driven gear	1
7	8313	GASKET, Vacuum pump	1
8	60430	COVER, Vacuum pump	1
9	STD-8	WASHER, 1/4 plain	4
10	STD-160	WASHER, 1/4 lock	4
11	STD-1411	NUT, 1/4-20 plain	4

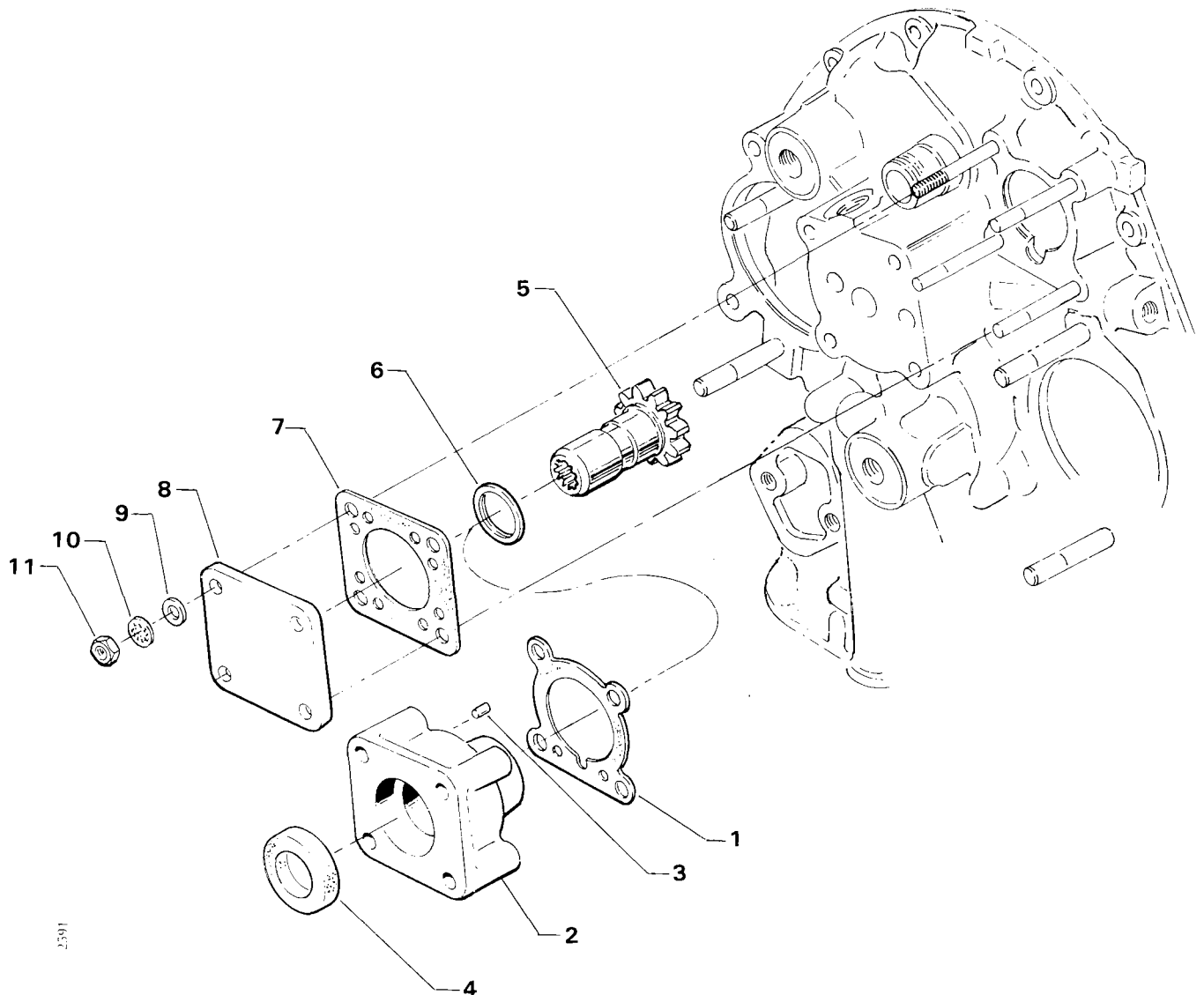

Figure 12. VACUUM PUMP DRIVE AND COVER

ACCESSORY HOUSING AND RELATED PARTS
OIL FILTER ASSEMBLY AND OIL COOLER BYPASS VALVE

FIG. REF. 13	PART NUMBER	DESCRIPTION	QUANTITY PER ASSEMBLY
1	LW-12795	GASKET, Oil filter adapter	2
2	LW-12999	PLATE, Oil filter adapter	1
3	77852	BASE ASSY., Oil filter	1
4	LW-13215	OIL FILTER, Short, spin-on	1
5	STD-8	WASHER, 1/4 plain	4
6	STD-160	WASHER, 1/4 lock	1
7	STD-1411	NUT, 1/4-20 plain	1
8	STD-1856	SCREW, 1/4-20 x 1.00 hex. hd., self-locking	3
9	75944	VALVE ASSY., Temp. control, oil cooler bypass	1
10	76510	GASKET, Valve assembly	1
11	25C-10	STUD, 1/4-20 x 1-1/4 long	1
12	STD-294	GASKET, 7/8 x 5/8 I.D. x 3/32 annular	1
13	62417	PLUG, Oil cooler bypass	1
14	STD-784	PLUG, 3/8 NPT	2

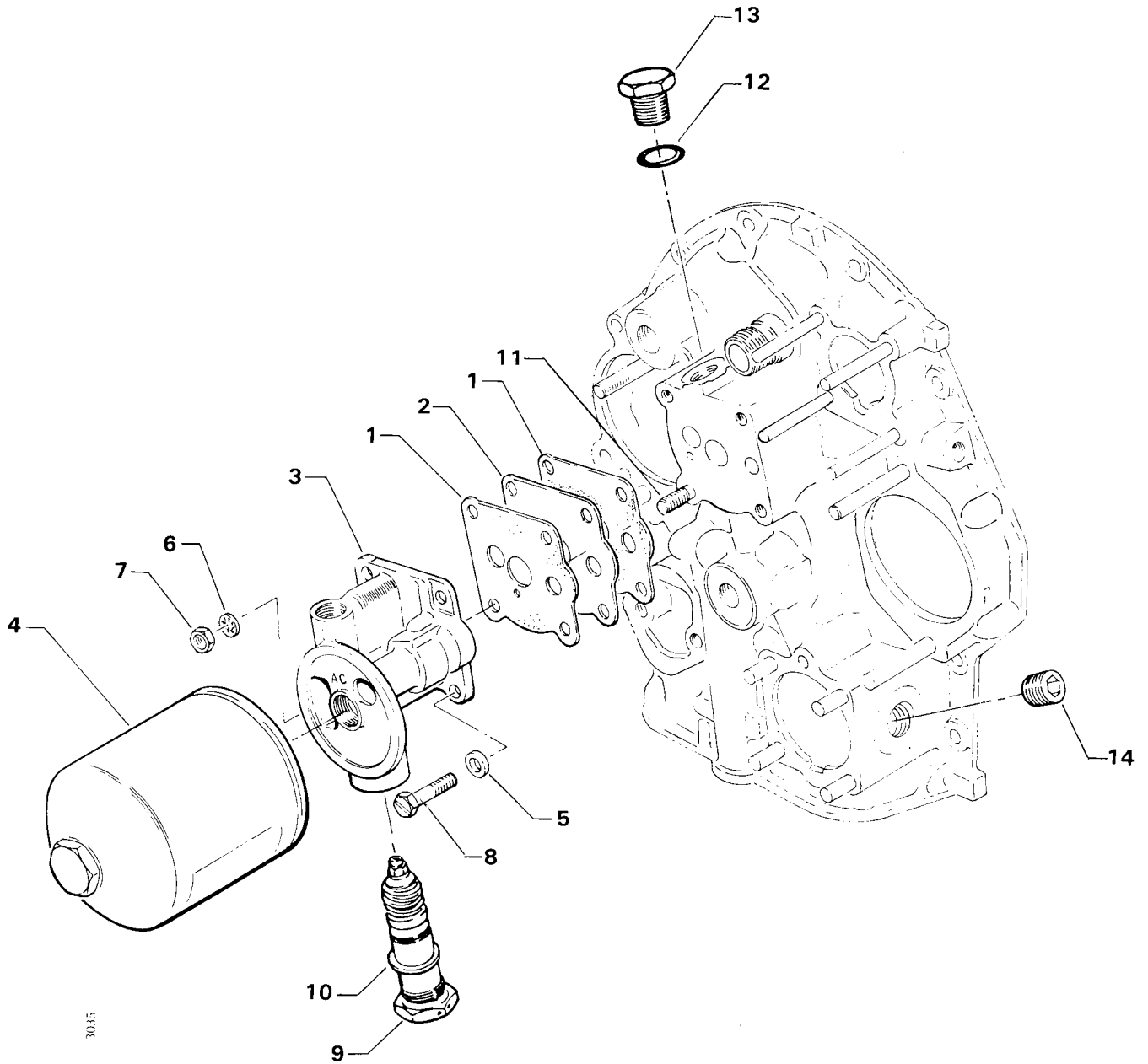

Figure 13. OIL FILTER ASSEMBLY AND OIL COOLER BYPASS VALVE

LYCOMING

O-235-P2A PARTS CATALOG

CYLINDER, PISTON AND VALVE TRAIN CONNECTING RODS, PISTONS AND RING ASSEMBLIES

FIG. REF. 14	PART NUMBER	DESCRIPTION	QUANTITY PER ASSEMBLY
1	78030	ROD ASSY., Connecting	4
2	LW-13923	BUSHING, Connecting rod, upper	4
3	78027	BOLT, Connecting rod	8
4	LW-12186	NUT, Connecting rod	8
5	69373	BEARING, Connecting rod	8
6	LW-13623	PISTON, Compression ratio 8.5:1	4
7	LW-13445	PIN, Piston	4
8	LW-11625	PLUG, Piston pin	8
9	78862	RING, Piston, compression	8
10	78864	RING, Piston, oil regulating, expander type	4

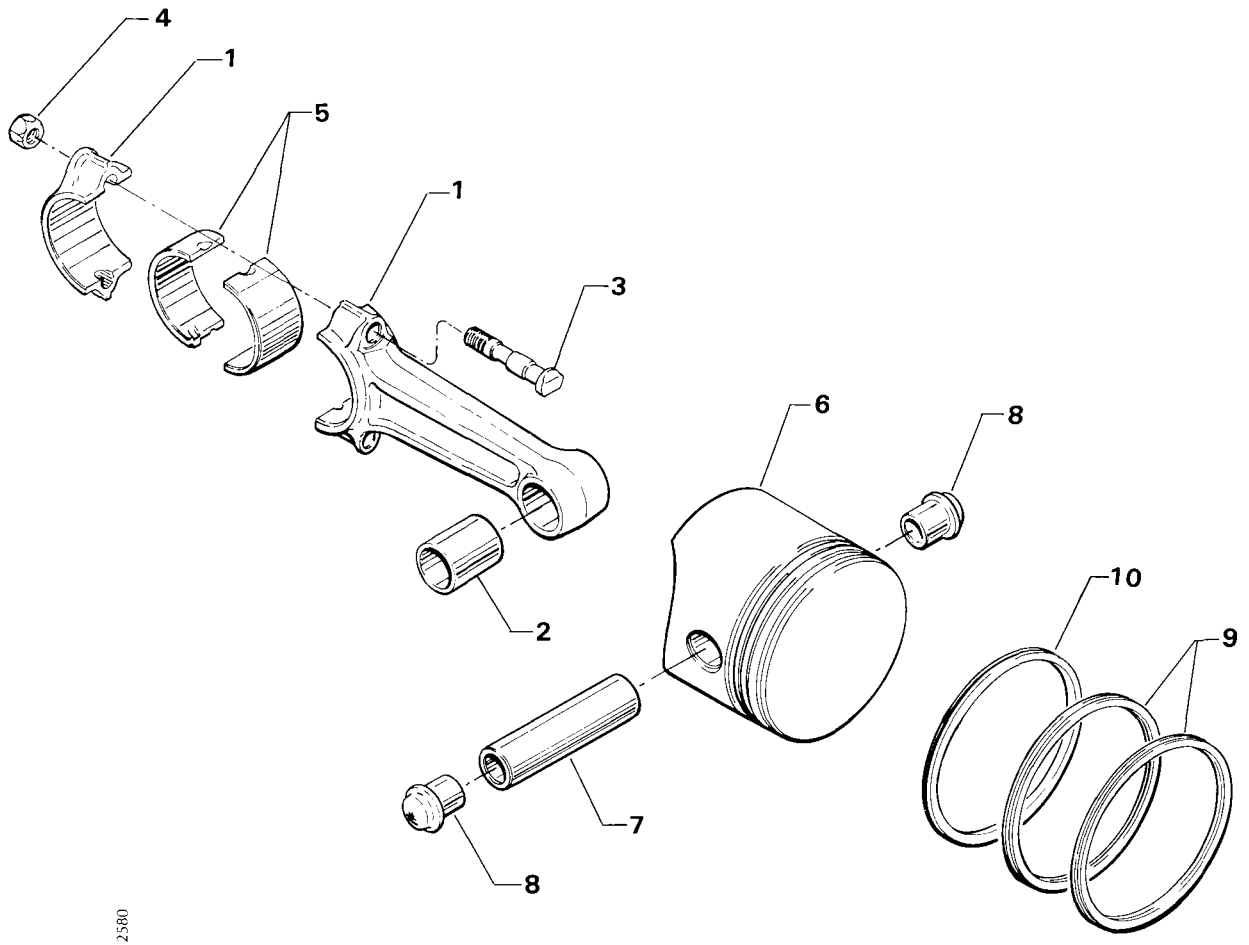

2580

Figure 14. CONNECTING RODS, PISTONS AND RING ASSEMBLIES

LYCOMING

O-235-P2A PARTS CATALOG

CYLINDER, PISTON AND VALVE TRAIN CYLINDER ASSEMBLY

FIG. REF. 15	PART NUMBER	DESCRIPTION	QUANTITY PER ASSEMBLY
1	LW-18290*	CYLINDER & HEAD ASSY., Nitrided	4
2	LW-11900	SEAT, Intake valve	4
3	LW-16699	SEAT, Exhaust valve (Allison valve seat)	4
4	61681	GUIDE, Valve, intake (flanged)	4
5	LW-11626	GUIDE, Valve, exhaust (flanged)	4
6	66796	INSERT, Spark plug, 18-1.5 MM	8
7	31C-12	STUD, 5/16-18 x 1-1/2 long	8
8	STD-700	ELBOW, 90°, 3/8 flared tube	4

* Incorporates Allison exhaust valve seats.

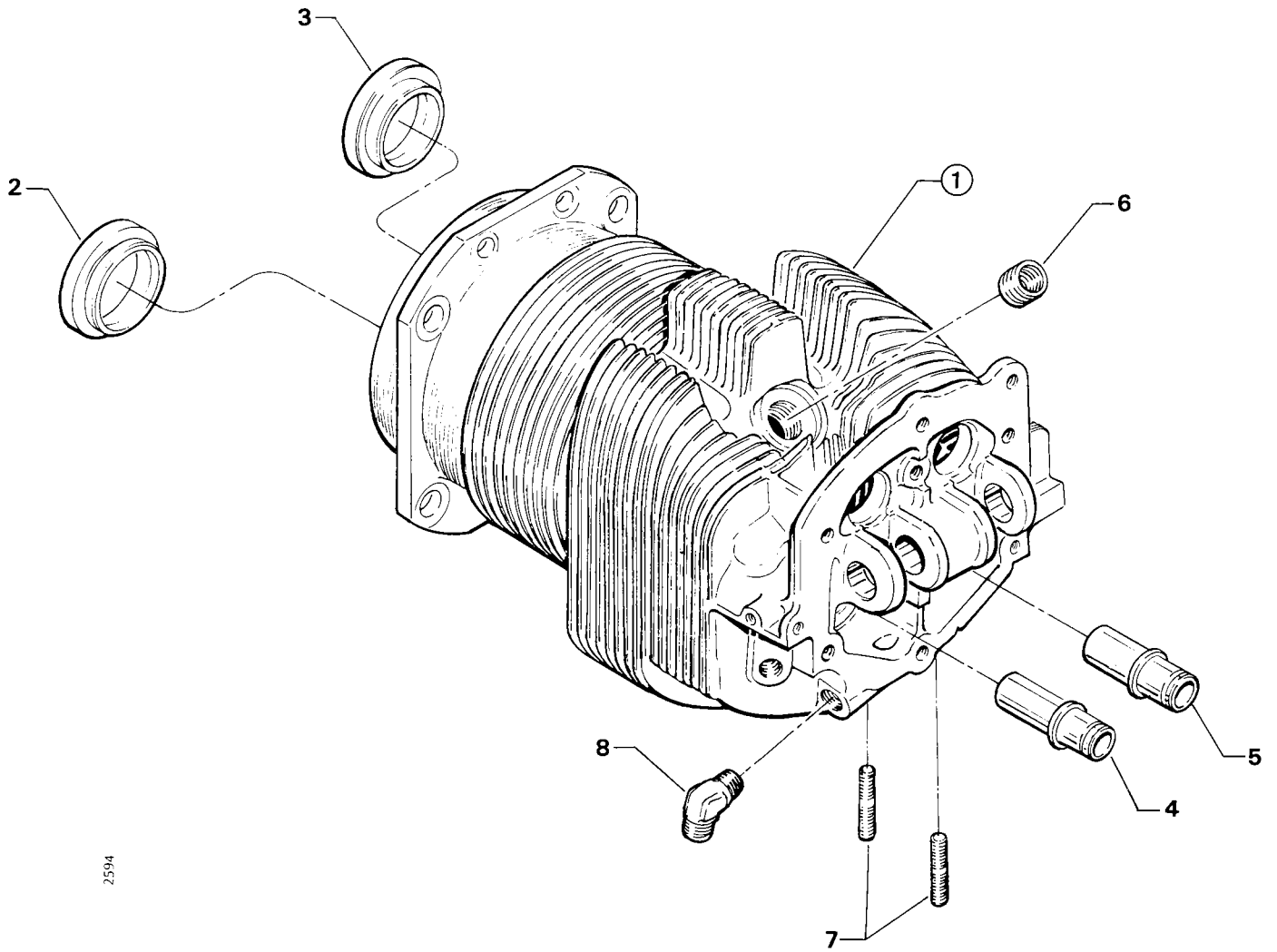

2594

Figure 15. CYLINDER ASSEMBLY

LYCOMING

O-235-P2A PARTS CATALOG

CYLINDER, PISTON AND VALVE TRAIN CYLINDER RELATED PARTS

FIG. REF. 16	PART NUMBER	DESCRIPTION	QUANTITY PER ASSEMBLY
1	383-B	NUT, 3/8-24 plain	16
2	STD-2106	NUT, 7/16-20 plain	16
3	73806	ROD ASSY., Push	8
4	60831	ROCKER ASSY., Valve	8
5	60398	BUSHING, Valve rocker	8
6	73807	SCREW, Valve adjusting	8
7	STD-587	NUT, 9/16-18 x 5/32 thick	8
8	LW-13790	SHAFT, Valve rocker	4
9	LW-12892	THRUST BUTTON, Rocker shaft	8
10	75906	GASKET, Rocker box	4
11	61247	COVER, Rocker box	4
12	STD-1925	SCREW, 1/4-20 x 5/8, self-locking	24
13	STD-35	WASHER, 5/16 plain	8
14	STD-475	WASHER, 5/16 lock, internal teeth	8
15	STD-1410	NUT, 5/16-18 plain	8
16	62869	RING, Oil seal, 3/32 dia. x 4-3/8	4
17	LW-19296	GASKET, Exhaust flange	4
18	61260	FLANGE, Exhaust, stainless	4

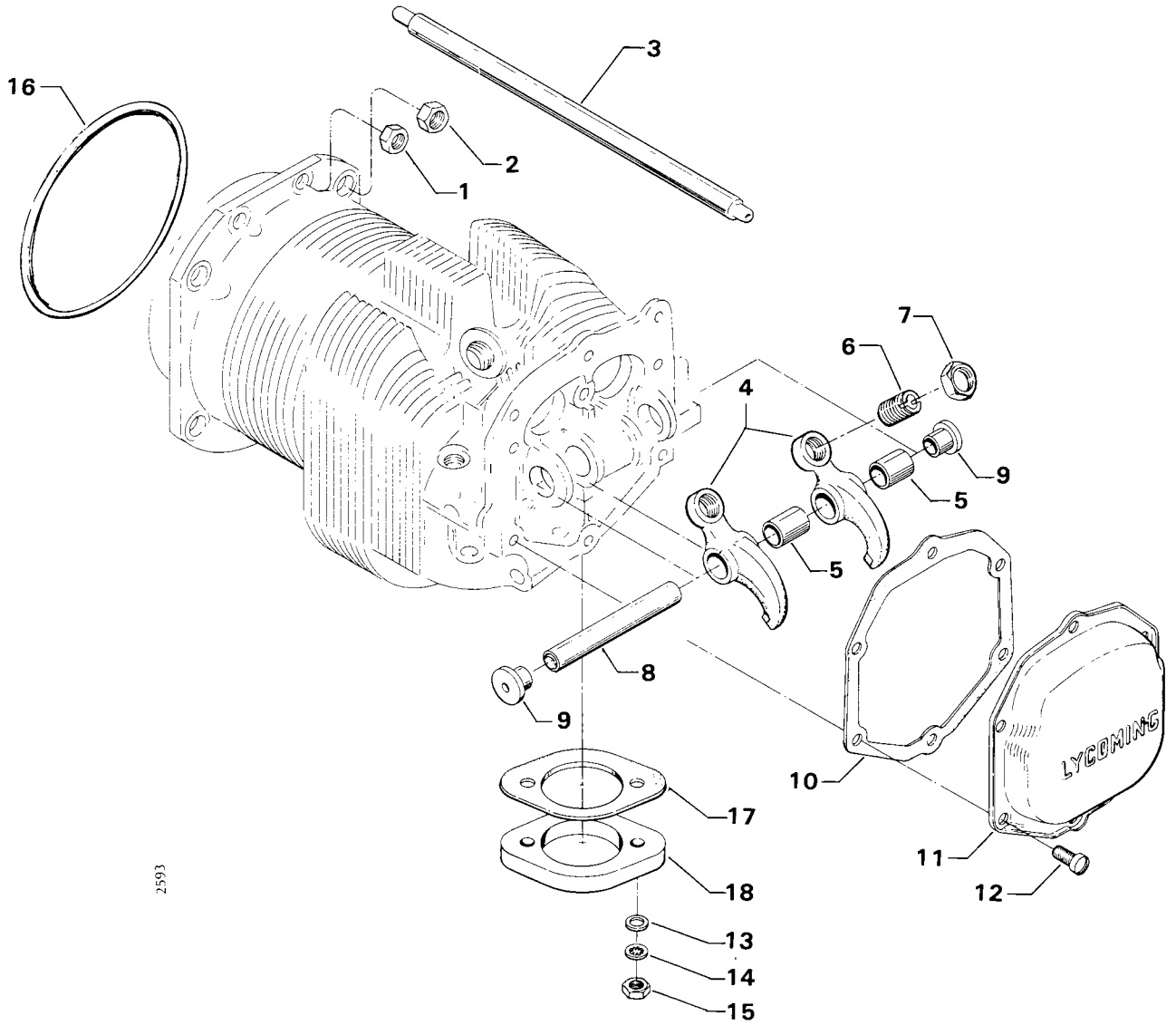

2593

Figure 16. CYLINDER RELATED PARTS

LYCOMING

O-235-P2A PARTS CATALOG

CYLINDER, PISTON AND VALVE TRAIN VALVE ASSEMBLY

FIG. REF. 17	PART NUMBER	DESCRIPTION	QUANTITY PER ASSEMBLY
1	LW-11901	VALVE, Intake	4
2	LW-19034	VALVE, Exhaust	4
3	61252	SEAT, Valve spring, outer	8
4	LW-13320	SEAT, Valve spring, inner	8
5	LW-11795	SPRING, Valve, auxiliary	8
6	LW-11800	SPRING, Valve, outer	8
7	LW-10077	SEAT, Valve spring	8
8	60009	KEY, Valve	16
9	LW-18661	SEAL, Shroud tube	16
10	60903	TUBE, Push rod shroud	16

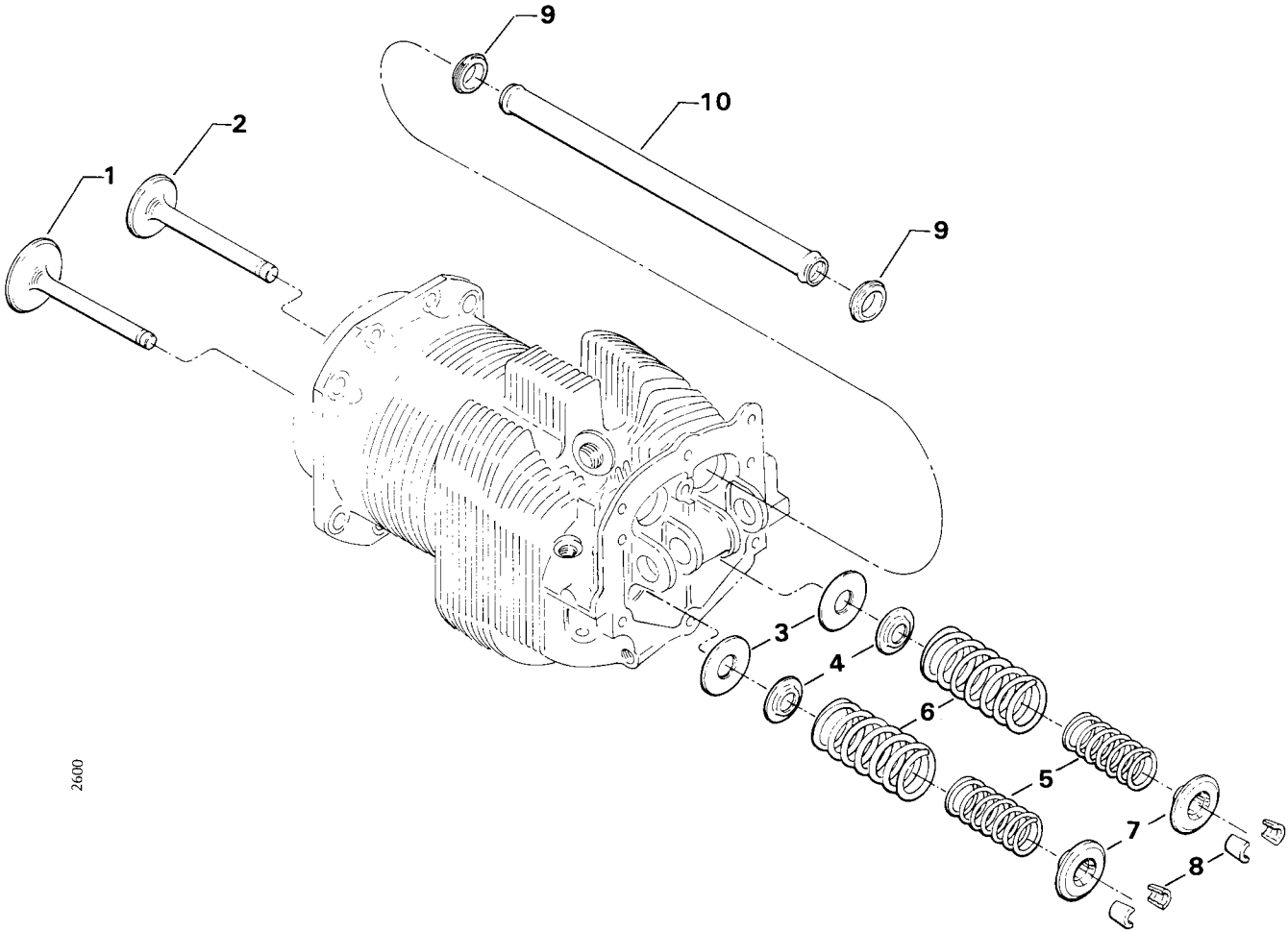

2600

Figure 17. VALVE ASSEMBLY

LYCOMING

O-235-P2A PARTS CATALOG

CYLINDER, PISTON AND VALVE TRAIN CYLINDER HEAD DRAIN TUBES AND INTERCYLINDER COOLING BAFFLES

FIG. REF. 18	PART NUMBER	DESCRIPTION	QUANTITY PER ASSEMBLY
1	STD-684	NIPPLE, Straight, 3/8 I.D. hose	4
2	STD-2180	HOSE, 3/8 I.D. x 1-13/16 long	4
3	LW-15592-5-05	CLAMP, Hose	8
4	60890	TUBE ASSY., Oil drain, cyl. no. 1	1
5	60821	TUBE ASSY., Oil drain, cyl. no. 2	1
6	60928	TUBE ASSY., Oil drain, clys. no. 3 & 4	2
7	LW-13304	BAFFLE ASSY., Intercylinder	2
8	71611	RETAINER, Intercylinder baffle	2
9	LW-13303	HOOK, Intercylinder baffle retainer	2
10	65614	PLUG, Baffle attaching	4
11	STD-251	WASHER, No. 10 lock	4
12	STD-665	SCREW, No. 10-32 x 3/4 long, fill. hd. dr.	4

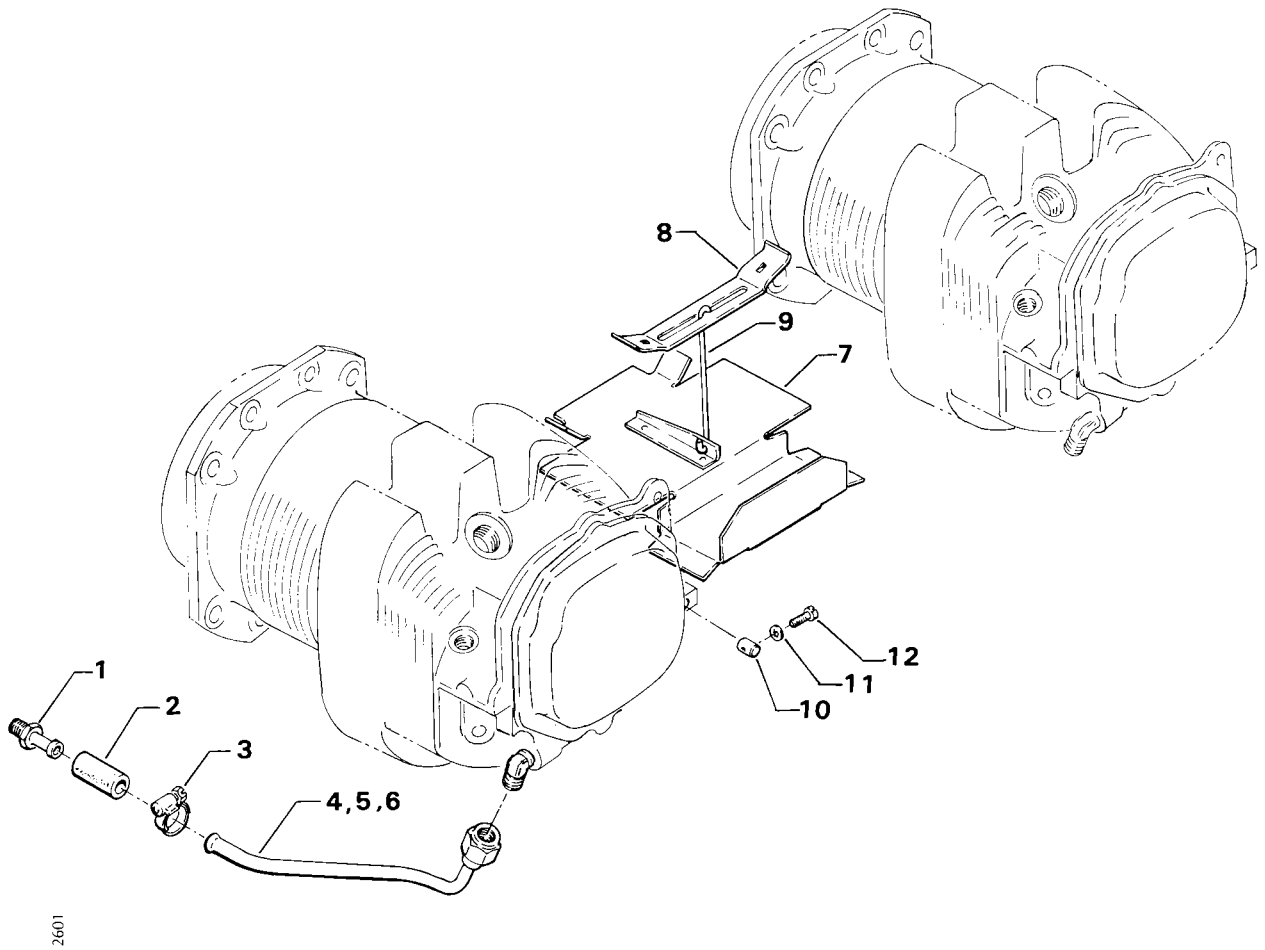

Figure 18. CYLINDER HEAD DRAIN TUBES AND INTERCYLINDER COOLING BAFFLES

IGNITION SYSTEM MAGNETOS, DRIVES, HARNESSES AND SPARK PLUGS

FIG. REF. 19	PART NUMBER	DESCRIPTION	QUANTITY PER ASSEMBLY
1	61665	GEAR, Magneto, impulse coupling	1
2	61163	GEAR, Magneto	1
3	62224	GASKET, Magneto adapter and magneto	3
4	LW-12706	ADAPTER, Magneto, impulse coupling	1
5	LW-163045-6	MAGNETO, S4LN-204 (with electric tach. pickup)	1
	LW-51360-54	MAGNETO, Impulse coupling, S4LN-21	1
6	STD-1727	WASHER, Plain, 3/4 O.D. x 21/64 I.D. x 1/8 thick	4
7	STD-475	WASHER, 5/16 lock, internal teeth	4
8	STD-1410	NUT, 5/16-18 plain	4
9	LW-157209	KIT, Magneto ground terminal (w/S4LN-204)	1
	LW-52305-1	KIT ASSY., Magneto ground terminal (w/S4LN-21)	1
10	LW-M-2403	HARNESS ASSY., Left magneto (Slick)	1
	LW-M-2404	HARNESS ASSY., Right magneto (Slick)	1
11	LW-M-2375	PLATE, Spark plug cable	2
12	LW-14060	CLIP, Two wire for 1/4 screw	3
13	STD-8	WASHER, 1/4 plain	1
14	STD-160	WASHER, 1/4 lock, internal teeth	2
15	AN500-416-12	SCREW, 1/4-20 x 3/4 long, fill. head	1
16	STD-1411	NUT, 1/4-20 plain	1
17	AN500A-416-10	SCREW, 1/4-20 x 5/8 long	1
18	LW-18959-150-25	CLAMP, 1-1/2 I.D., offset	4
19	STD-553	SCREW, 6/32 x 1/2 long, rd. hd.	4
20	AN365-632A	NUT, 6/32 self-locking	4
21	LW-16266-25-50	CLAMP	1
22	76734	ZIP STRAP	2
23	1182-B7	SPARK PLUG, (Champion REM-37BY) shielded	8
*	M-1985-48	LEAD ASSY., Replacement top & bottom leads	AR

* Replacement lead assemblies have spark plug terminal end assembled and are shipped with necessary parts to complete magneto end assembly after being cut to proper length.

NOTE

The above spark plugs are those used in current production only; this list does not include additional spark plugs that are approved for use in these engines. See latest edition of Service Instruction No. 1042 for complete listing of all approved spark plugs.

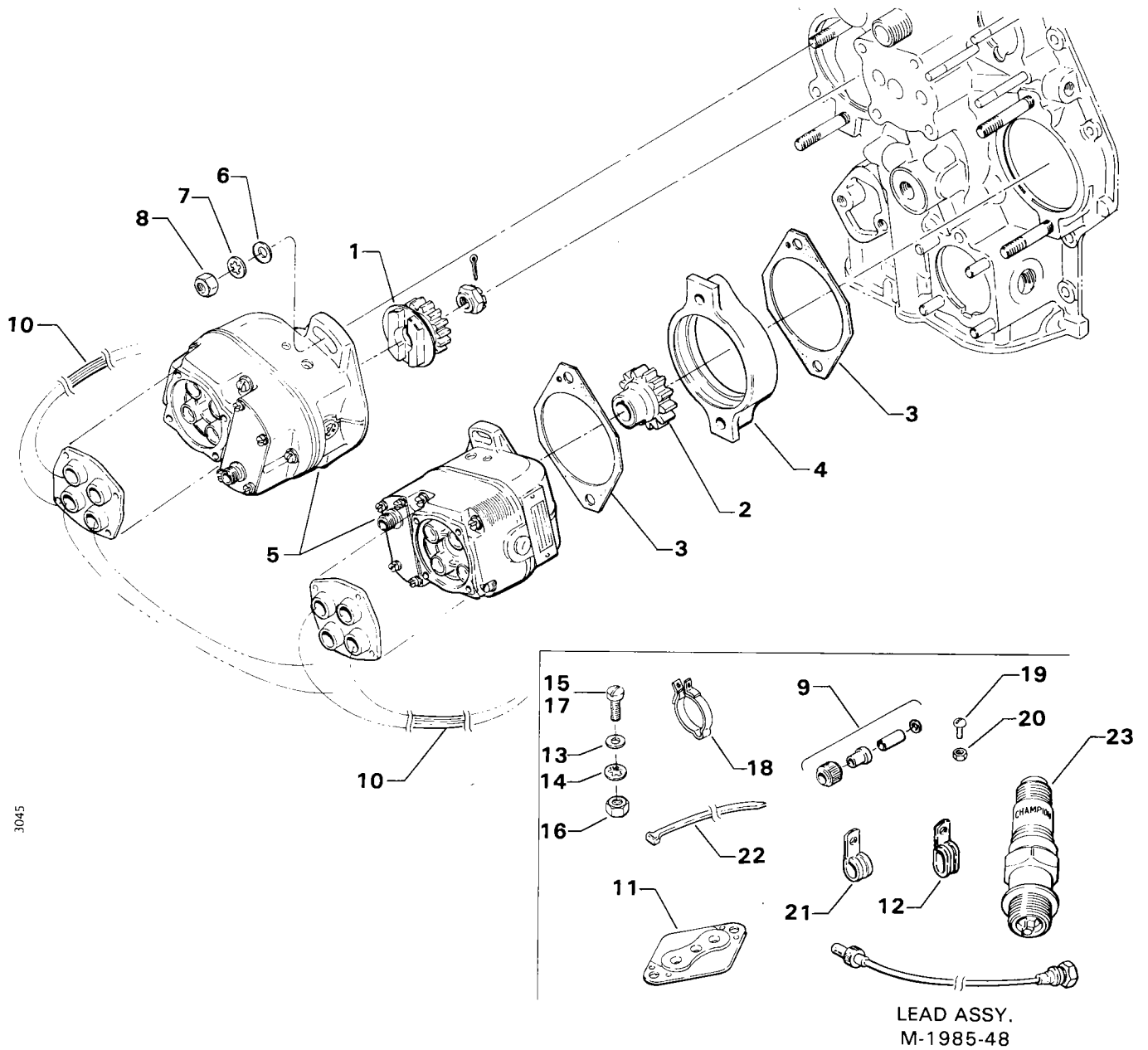
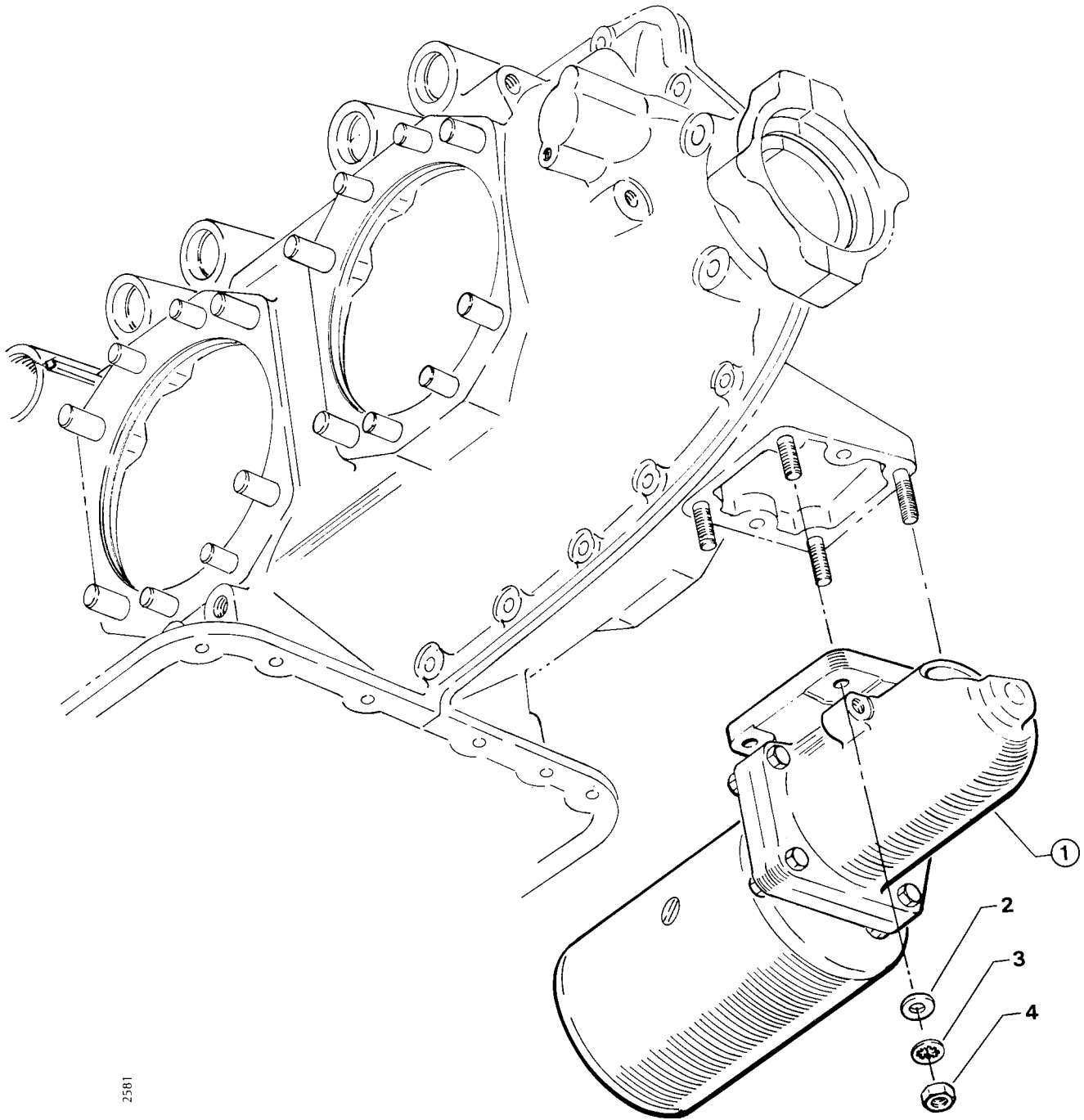

Figure 19. MAGNETOS, DRIVES, HARNESSES AND SPARK PLUGS

ELECTRICAL COMPONENTS
STARTER MOTOR AND ATTACHING PARTS

FIG. REF. 20	PART NUMBER	DESCRIPTION	QUANTITY PER ASSEMBLY
1	76210	STARTER, 12 volt, 10/12 pitch pinion (MZ-4204)	1
2	STD-35	WASHER, 5/16 plain	4
3	STD-475	WASHER, 5/16 lock, internal teeth	4
4	STD-1410	NUT, 5/16-18 plain	4



2581

Figure 20. STARTER MOTOR AND ATTACHING PARTS

LYCOMING

O-235-P2A PARTS CATALOG

OIL SUMP AND INDUCTION SYSTEM OIL SUMP ASSEMBLY AND OIL SUCTION SCREEN

FIG. REF. 21	PART NUMBER	DESCRIPTION	QUANTITY PER ASSEMBLY
1	LW-13353	GASKET, Oil sump	1
2	LW-15688	SUMP ASSY., Oil	1
3	61376	CONNECTION, Intake pipe, front	2
4	61377	CONNECTION, Intake pipe, rear	2
5	25C-12	STUD, 1/4-20 x 1-1/2 long	4
6	STD-551	PLUG, 1/2-14 NPT, sq. hd.	1
7	STD-8	WASHER, 1/4 plain	32
8	STD-160	WASHER, 1/4 lock, internal teeth	20
9	LW-25-0.94	BOLT, 1/4-20 x 15/16 long, hex. head	18
10	STD-1411	NUT, 1/4-20 plain	14
11	60820	GASKET, Oil suction tube flange	1
12	61381	TUBE ASSY., Oil suction	1
13	STD-1227	WASHER, 1/4 plain, copper	2
14	STD-1433	BOLT, 1/4-20 x 1-1/2 long, hex. hd., drilled end	2
15	STD-8	WASHER, 1/4 plain (max. 4)	AR
16	STD-1409	NUT, 1/4-20 slotted shear	2
17	STD-68	PIN, Cotter, 1/16 x 1/2 long	2
18	61378	SCREEN, Oil suction	1
19	STD-1045	GASKET, 1-1/4 I.D. x 1-1/2 O.D. x 3/32 annular	1
20	61358	PLUG, 1-1/2 x 1-1/4-12, hex. hd.	1

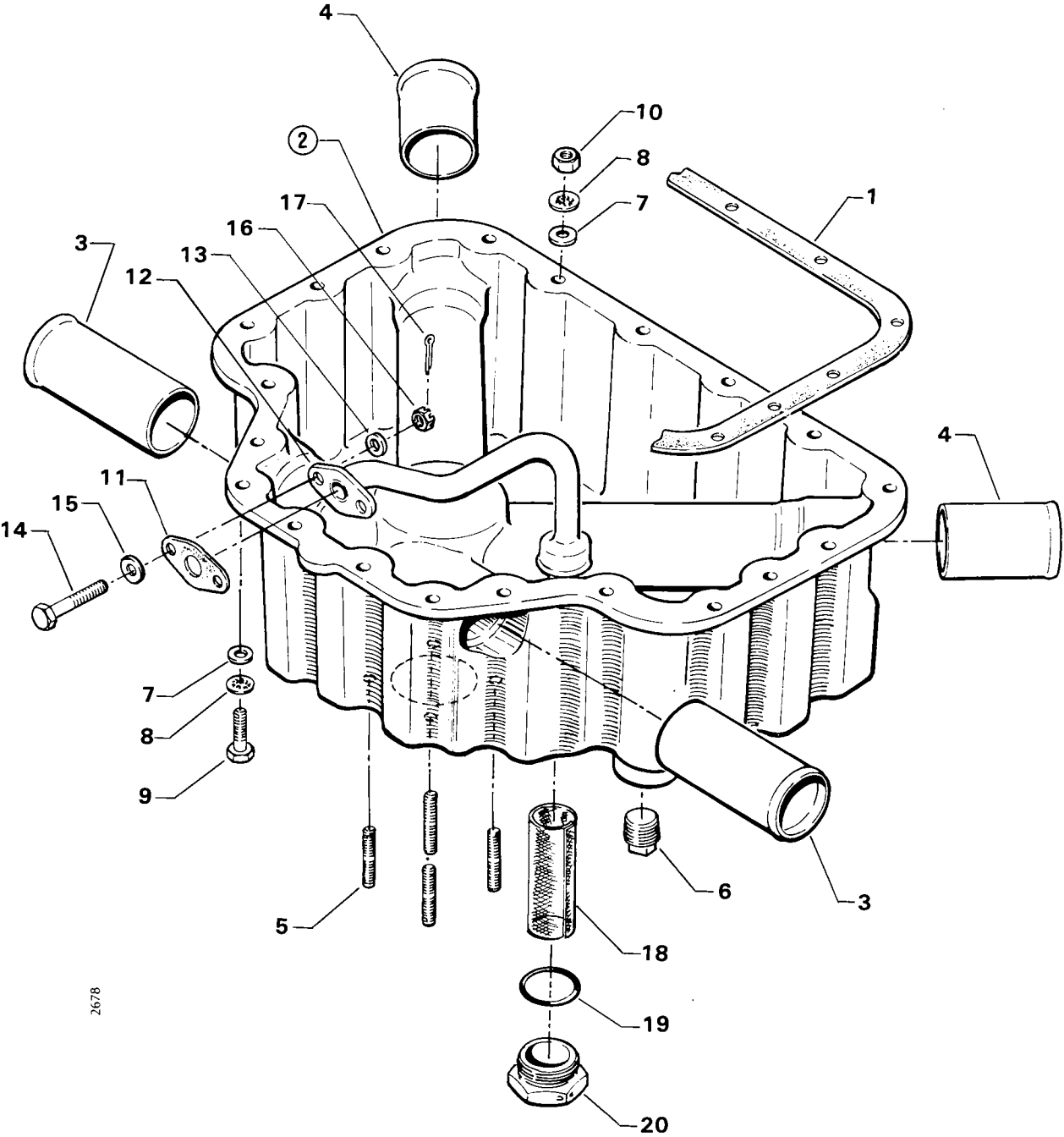

2678

Figure 21. OIL SUMP ASSEMBLY AND OIL SUCTION SCREEN

OIL SUMP AND INDUCTION SYSTEM
INTAKE PIPE ASSEMBLY

FIG. REF. 22	PART NUMBER	DESCRIPTION	QUANTITY PER ASSEMBLY
1	LW-16728	PIPE, Intake cyls. nos. 1 & 2	2
2	LW-16730	PIPE, Intake cyl. no. 3	1
3	LW-16729	PIPE, Intake cyl. no. 4	1
4	STD-1196	HOSE, 1-1/2 I.D. x 1-7/8 O.D. x 1-1/2 long	4
5	LW-15592-8-28	CLAMP, Hose	8
6	71973	GASKET, 2 bolt flange, 1-3/4 I.D.	4
7	74360	FLANGE, Intake pipe, upper	4
8	STD-8	WASHER, 1/4 plain	8
9	STD-160	WASHER, 1/4 lock, internal lock	8
10	LW-25-1.25	BOLT, 1/4-20 x 1-1/4 long, hex. hd.	8

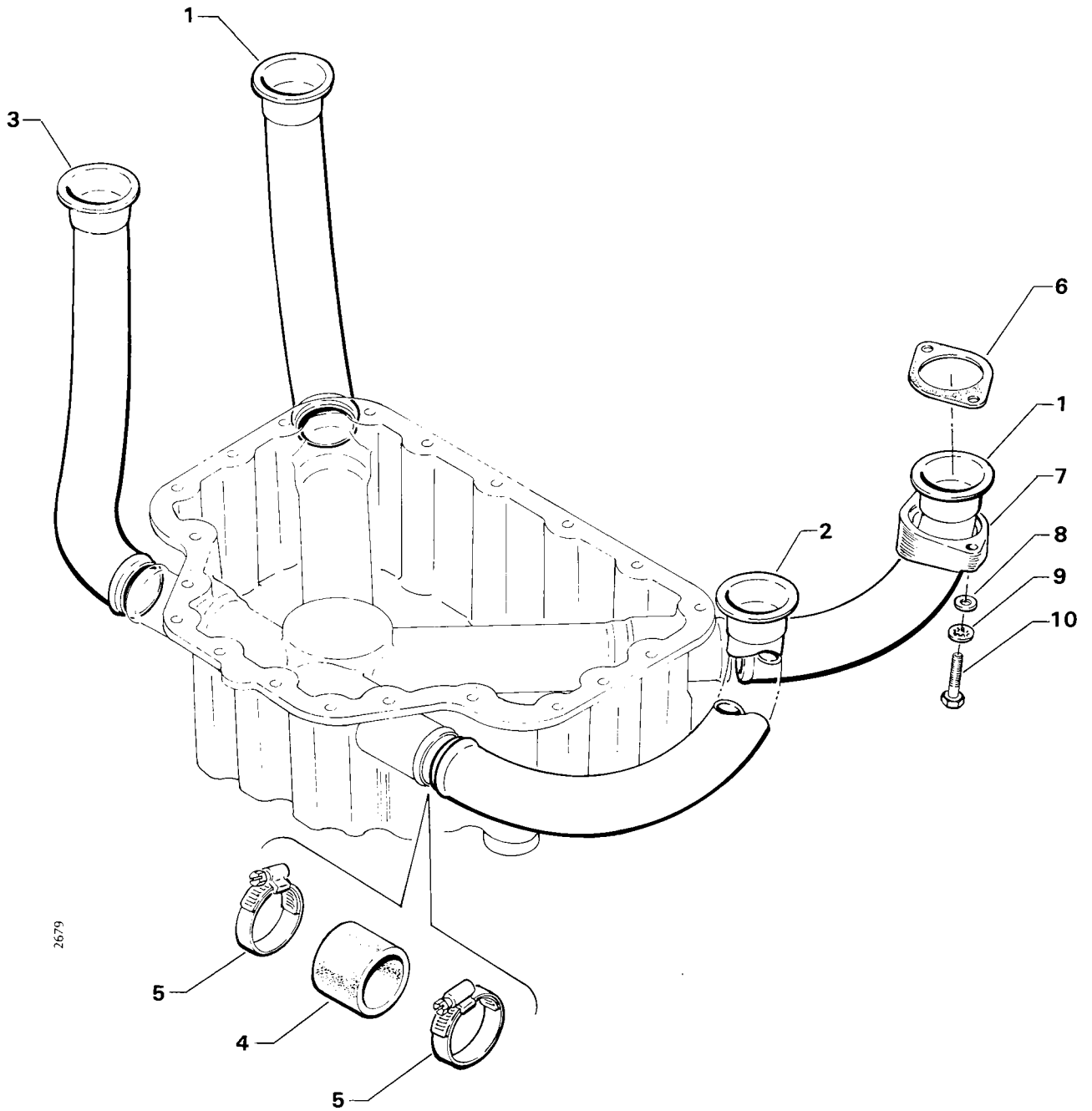

Figure 22. INTAKE PIPE ASSEMBLY

OIL SUMP AND INDUCTION SYSTEM
CARBURETOR ASSEMBLY

FIG. REF. 23	PART NUMBER	DESCRIPTION	QUANTITY PER ASSEMBLY
1	60592	GASKET, Carburetor	1
2	LW-16073	CARBURETOR, Marvel-Schebler, MA-3PA (10-5220)	1
3	STD-8	WASHER, 1/4 plain	4
4	STD-160	WASHER, 1/4 lock, internal teeth	4
5	STD-1411	NUT, 1/4-20 plain	4

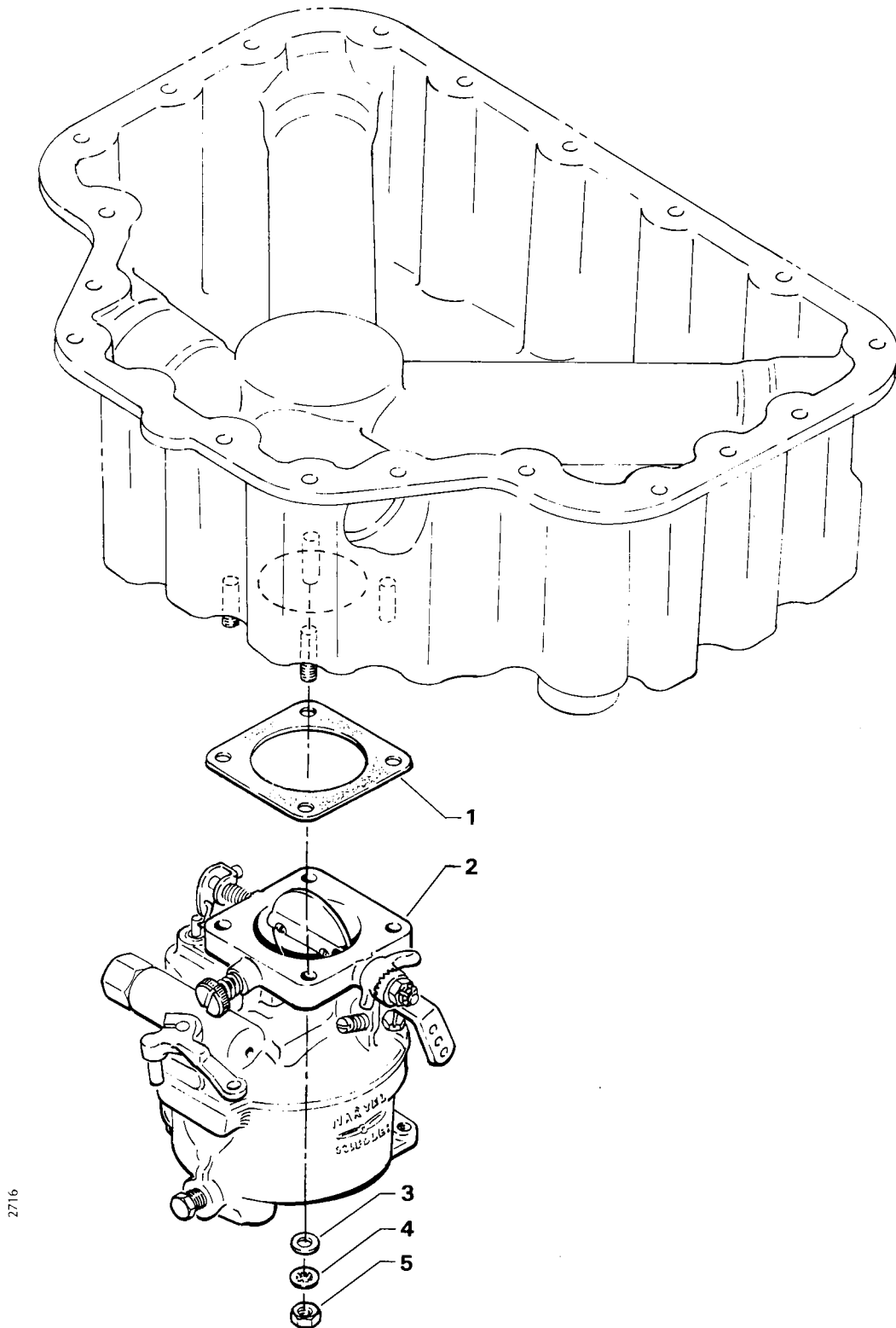

Figure 23. CARBURETOR ASSEMBLY

LYCOMING

O-235-P2A PARTS CATALOG

OIL SUMP AND INDUCTION SYSTEM PRIMING SYSTEM

FIG. REF. 24	PART NUMBER	DESCRIPTION	QUANTITY PER ASSEMBLY
1	LW-12098-1-170	TUBE ASSY., Primer cylinder no. 2	1
2	LW-12098-1-116	TUBE ASSY., Primer cylinder no. 4	1
3	LW-12098-1-284	TUBE ASSY., Primer cylinder no. 1	1
4	LW-12098-0-100	TUBE ASSY., Primer, intermediate	1
5	LW-16266-25-13	CLAMP	3
6	LW-18959-150-25	CLAMP, 1-1/2 I.D. with 1/4 dia. offset	3
7	STD-553	SCREW, No. 6-32 x 1/2 long, rd. hd.	3
8	AN365-632A	NUT, No. 6-32 self-locking	3
9	STD-853	TEE, Union, 1/8 tube	1
10	LW-18071	TEE, Union, 1/8 tube	1
11	74225	NIPPLE ASSY., Primer	3
12	1102*	PLUG, 1/8 NPT, Allen head	1

* Assemble in cylinder head.

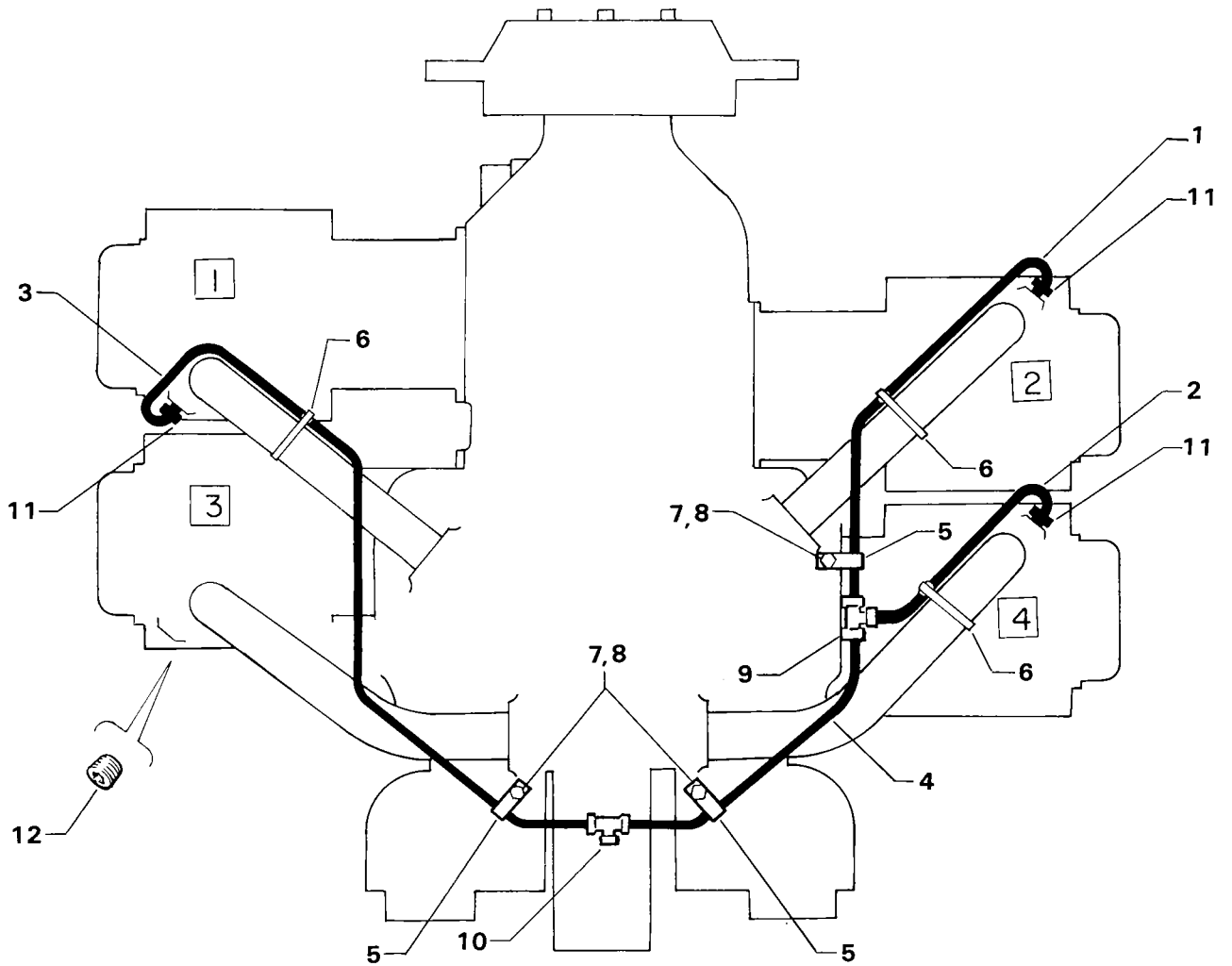

3044

Figure 24. PRIMING SYSTEM

SERVICE KIT SECTION

SEAL AND GASKET SET
WIDE CYLINDER FLANGE MODELS

Part No.	Part Name	Qty.
61499-1	SEAL AND GASKET SET	1
STD-111	GASKET	1
STD-2217	SEAL, Oil	1
STD-294	GASKET, Annular	2
STD-1045	GASKET, Annular	2
8313	GASKET, Vac. pump	2
60096	GASKET, Fuel pump	1
60592	GASKET, Carb.	1
60820	GASKET, Oil suction tube flange	1
LW-18639	LOCKPLATE, Crankshaft gear	1
LW-14260	SEAL, Tach. shaft	1
61173	GASKET, Oil press. hsg.	1
61183	GASKET, Accy. adapter	1
61523	CONTAINER	1
61531	GASKET, Hydraulic valve	1
62224	GASKET, Mag. adapter	3
LW-18661	SEAL, Shroud tube	16
LW-19296	GASKET, Exhaust flange	4
68315	GASKET, Accy. dr. adapter	1
LW-13353	GASKET, Oil sump	1
71973	GASKET, Intake flange	4
72053	GASKET, Gov. drive	1
72059	GASKET	1
72078	LOCKPLATE, Cam gear	2
72091	RING, Oil seal	8
73383	LOCKPLATE	1
73817	LOCKPLATE, Camshaft idler gear shaft	2
73818	GASKET, Accy. hsg.	1
74065	RING, Oil level gage seal	1
74068	RING, Oil level gage seal	1
75906	GASKET, Rocker box cover	4
76940	SEAL, Crankshaft oil	1
LW-13792	SEAL, Crankshaft oil	1
LW-12681	GASKET, Mag.	2
LW-12795	GASKET	1
LW-11632	RING, Oil seal	6
62869	RING, Cyl. base	4
LW-12040	TOP OVERHAUL GASKET SET	1
62869	SEAL, Cylinder base	4
LW-18661	SEAL, Shroud tube	16
71973	GASKET, Intake, 2 bolt flange	4
75906	GASKET, Rocker box cover	4

SERVICE KIT SECTION

CYLINDER, PISTON AND RING KIT
WIDE CYLINDER FLANGE MODELS

Part No.	Part Name	Qty.
LW-18660	CYLINDER, PISTON AND RING ASSEMBLY	1
STD-587	NUT, 9/16-18 x 5/32 thick	2
STD-1215	BOLT	2
STD-1925	SCREW, 1/4-20 x 5/8 long, fill. hd.	6
1102	PLUG, 1/8 pipe x 3/8 long, socket	1
60009	KEY, Valve	4
60831	ROCKER ASSY., Valve	2
61247	COVER, Rocker box	1
LW-13320	SEAT, Valve spring, inner	2
61252	SEAT, Valve spring, outer	2
LW-13790	SHAFT, Valve rocker	1
62869	RING, Oil seal (cylinder base)	1
LW-18661	SEAL, Shroud tube	4
71195	BOX, Set-up	1
73807	SCREW, Valve adjusting	2
75906	GASKET, Rocker box cover	1
LW-13445	PIN, Piston	1
78862	RING, Piston compression	2
78864	RING, Piston, oil regulator	1
LW-10077	SEAT, Valve spring	2
LW-13623	PISTON	1
LW-11625	PLUG, Piston pin	2
LW-18290	CYLINDER ASSY., Nitrided	1
LW-19034	VALVE, Exhaust	1
LW-11795	SPRING, Valve, auxiliary	2
LW-11800	SPRING, Valve, outer	2
LW-11901	VALVE, Intake	1
LW-12892	THRUST BUTTON	2

NUMERICAL INDEX

PART NO.	PART NAME	PAGE NO.	PART NO.	PART NAME	PAGE NO.
AN365-632A	Nut	4-1	LW-163045-6	Magneto	4-1
AN365-632A	Nut	6-7	LW-16354	Crankcase Assy.	1-1
AN500-416-12	Screw	4-1	LW-16699	Seat	3-3
AN500A-416-10	Screw	4-1	LW-16728	Pipe	6-3
AN6-21	Bolt	1-11	LW-16729	Pipe	6-3
AN6-34A	Bolt	1-11	LW-16730	Pipe	6-3
LW-10077	Seat	3-7	LW-18071	Tee	6-7
LW-11622	Stud	1-1	LW-18109	Impeller	2-3
LW-11623	Stud	1-1	LW-18110	Impeller Assy.	2-3
LW-11625	Plug	3-1	LW-18290	Cylinder Assy.	3-3
LW-11626	Guide	3-3	LW-18639	Lockplate	1-5
LW-11795	Spring	3-7	LW-18661	Seal	3-7
LW-11800	Spring	3-7	LW-18667	Pin	1-9
LW-11900	Seat	3-3	LW-18959-150-25	Clamp	4-1
LW-11901	Valve	3-7	LW-18959-150-25	Clamp	6-7
LW-12044	Housing Assy.	2-1	LW-19034	Valve	3-7
LW-12098-0-100	Tube Assy.	6-7	LW-19296	Gasket	3-5
LW-12098-1-116	Tube Assy.	6-7	LW-25-0.94	Bolt	2-3
LW-12098-1-170	Tube Assy.	6-7	LW-25-0.94	Bolt	6-1
LW-12098-1-284	Tube Assy.	6-7	LW-25-1.25	Bolt	6-3
LW-12186	Nut	3-1	LW-25-1.50	Bolt	1-11
LW-12695	Crankshaft Assy.	1-5	LW-25S1.50	Bolt	1-11
LW-12706	Adapter	4-1	LW-25-1.75	Bolt	1-11
LW-12795	Gasket	2-11	LW-25-2.00	Bolt	2-3
LW-12892	Thrust Button	3-5	LW-51360-54	Magneto	4-1
LW-12999	Plate	2-11	LW-52305-1	Kit	4-1
LW-13215	Oil Filter	2-11	LW-M-2375	Plate	4-1
LW-13303	Hook	3-9	LW-M-2403	Harness Assy.	4-1
LW-13304	Baffle Assy.	3-9	LW-M-2404	Harness Assy.	4-1
LW-13320	Seat	3-7	M-1985-48	Lead Assy.	4-1
LW-13353	Gasket	6-1	MS20822-6	Elbow	2-5
LW-13445	Pin	3-1	STD-8	Washer	1-11
LW-13623	Piston	3-1	STD-8	Washer	2-3
LW-13675	Support Assy.	1-5	STD-8	Washer	2-10
LW-13790	Shaft	3-5	STD-8	Washer	2-11
LW-13792	Seal	1-7	STD-8	Washer	4-1
LW-13884	Bearing	1-7	STD-8	Washer	6-1
LW-13923	Bushing	3-1	STD-8	Washer	6-3
LW-14060	Clip	4-1	STD-8	Washer	6-5
LW-14260	Seal	2-3	STD-33	Washer	1-11
LW-14781	Gage Assy.	1-3	STD-33	Washer	2-9
LW-15472	Fuel Pump	2-9	STD-35	Washer	2-3
LW-15592-5-05	Clamp	3-9	STD-35	Washer	2-5
LW-15592-8-28	Clamp	6-3	STD-35	Washer	2-7
LW-15688	Sump Assy.	6-1	STD-35	Washer	3-5
LW-157209	Kit	4-1	STD-35	Washer	5-1
LW-16073	Carburetor	6-5	STD-68	Pin	6-1
LW-16266-25-13	Clamp	6-7	STD-160	Washer	1-11
LW-16266-25-38	Clamp	2-5	STD-160	Washer	2-3
LW-16266-25-50	Clamp	4-1	STD-160	Washer	2-10

NUMERICAL INDEX (Cont.)

PART NO.	PART NAME	PAGE NO.	PART NO.	PART NAME	PAGE NO.
STD-160	Washer	2-11	STD-1411	Nut	6-5
STD-160	Washer	4-1	STD-1420	Nut	2-3
STD-160	Washer	6-1	STD-1433	Bolt	6-1
STD-160	Washer	6-3	STD-1727	Washer	4-1
STD-160	Washer	6-5	STD-1774	Pin	2-7
STD-251	Washer	3-9	STD-1774	Pin	2-10
STD-294	Gasket	2-11	STD-1838	Bolt	2-5
STD-425	Washer	1-7	STD-1856	Screw	2-11
STD-475	Washer	2-5	STD-1882	Screw	2-9
STD-475	Washer	2-7	STD-1925	Screw	3-5
STD-475	Washer	3-5	STD-1930	Hose	2-5
STD-475	Washer	4-1	STD-2106	Nut	3-5
STD-475	Washer	5-1	STD-2180	Hose	3-9
STD-514	Dowel	1-1	STD-2213	Screw	1-5
STD-551	Plug	6-1	STD-2217	Seal	2-10
STD-553	Screw	4-1	25C-10	Stud	2-11
STD-553	Screw	6-7	25C-12	Stud	6-1
STD-557	Dowel	1-1	25C-22	Stud	2-1
STD-587	Nut	3-5	31C-12	Stud	1-1
STD-596	Nut	1-11	31C-12	Stud	2-1
STD-665	Screw	3-9	31C-12	Stud	3-3
STD-678	Washer	1-11	31C-16	Stud	2-7
STD-684	Nipple	3-9	31C-19	Stud	2-1
STD-700	Elbow	3-3	31CD-17	Stud	2-1
STD-705	Bolt	1-9	38-13	Stud	1-1
STD-783	Plug	2-1	44-13	Stud	1-1
STD-784	Plug	2-1	383B	Nut	3-5
STD-784	Plug	2-11	1028B	Ball	1-7
STD-853	Tee	6-7	1102	Plug	1-1
STD-872	Nut	1-11	1102	Plug	2-1
STD-1045	Gasket	1-7	1102	Plug	2-7
STD-1045	Gasket	6-1	1102	Plug	6-7
STD-1065	Dowel	1-5	1182-B7	Spark Plug	4-1
STD-1111	Elbow	1-1	8313	Gasket	2-10
STD-1196	Hose	6-3	45530	Ring	1-9
STD-1211	Plug	1-5	60009	Key	3-7
STD-1221	Ring	2-7	60096	Gasket	2-9
STD-1227	Washer	6-1	60398	Bushing	3-5
STD-1409	Nut	1-11	60430	Cover	2-10
STD-1409	Nut	6-1	60592	Gasket	6-5
STD-1410	Nut	2-7	60803	Strap	1-11
STD-1410	Nut	3-5	60814	Bushing	1-5
STD-1410	Nut	4-1	60820	Gasket	6-1
STD-1410	Nut	5-1	60821	Tube Assy.	3-9
STD-1411	Nut	1-11	60831	Rocker Assy.	3-5
STD-1411	Nut	2-3	60882	Gear	1-5
STD-1411	Nut	2-10	60890	Tube Assy.	3-9
STD-1411	Nut	2-11	60903	Tube	3-7
STD-1411	Nut	4-1	60928	Tube Assy.	3-9
STD-1411	Nut	6-1	61084	Spring	1-7

NUMERICAL INDEX (Cont.)

PART NO.	PART NAME	PAGE NO.	PART NO.	PART NAME	PAGE NO.
61098	Adapter Assy.	2-10	72059	Gasket	1-3
61151	Shaft	1-9	72091	Ring	1-7
61155	Gear	1-5	72378	Cover	2-7
61163	Gear	4-1	72844	Plug	1-3
61174	Shaft	2-3	72970	Gear Assy.	2-10
61175	Adapter	2-1	73757	Bushing	1-5
61183	Gasket	2-10	73806	Rod Assy.	3-5
61247	Cover	3-5	73807	Screw	3-5
61252	Seat	3-7	73817	Lockplate	1-9
61260	Flange	3-5	73818	Gasket	2-1
61358	Plug	6-1	74065	Ring	1-3
61376	Connection	6-1	74070	Elbow	2-5
61377	Connection	6-1	74225	Nipple Assy.	6-7
61378	Screen	6-1	74360	Flange	6-3
61381	Tube Assy.	6-1	74996	Gear Assy.	1-9
61400	Stud	2-1	75072	Gear Assy.	1-9
61510	Plug	1-5	75153	Adapter Assy.	2-7
61544	Plunger	1-9	76165	Clip	2-5
61665	Gear	4-1	75167	Tube Assy.	2-5
61681	Guide	3-3	75706	Camshaft	1-5
62224	Gasket	4-1	75708	Shaft Assy.	1-9
62417	Plug	2-11	75767	Tube	1-3
62869	Ring	3-5	75906	Gasket	3-5
65614	Plug	3-9	75944	Valve Assy.	2-11
66796	Insert	3-3	76210	Starter	5-1
68315	Gasket	2-7	76510	Gasket	2-11
68317	Shaftgear	2-7	76529	Plug	1-7
68763	Bearing	1-7	76734	Zip Strap	4-1
69373	Bearing	3-1	77309	Bushing	1-9
69796	Dowel	1-1	77852	Base Assy.	2-11
71105	Body	1-7	78027	Bolt	3-1
71596	Washer	2-7	78030	Rod Assy.	3-1
71596	Washer	2-10	78531	Body Assy.	2-3
71611	Retainer	3-9	78862	Ring	3-1
71973	Gasket	6-3	78864	Ring	3-1
72053	Gasket	2-7			