



AIRCRAFT ENGINES

INSTALLATION MANUAL

18) Electric system

18.1) General:

The engine is equipped with a breakerless 12V 170W DUCATI capacitor-discharge dual ignition system (447 UL SCDI is only equipped with a single ignition unit). It consists of a flywheel magneto generator, 2 double ignition coils complete with integrated control-circuit and 2 external trigger coils (pick-up).

The 12-pole flywheel generator is an outer rotor type with 12 integrated permanent magnets. The stator is equipped with 12 coils. 8 of them are used for feeding auxiliary equipment and 4 are used for the dual ignition. The grey cable is foreseen for connection of a revolution counter.

18.2) Function of the ignition unit:

Two charging coils fitted on the generator stator and independant from each other each feed one ignition circuit. The energy supplied is stored in the ignition capacitor. At the moment of ignition the external trigger coils supply an impulse to the control circuits and the ignition capacitors are discharged via the primary winding of the ignition coil. The secondary winding supplies the high voltage for the ignition spark.

■ ATTENTION: When flying both ignition systems must be switched ON.

18.3) Wiring diagram:

◆ NOTE: When replacing wiring on the ignition system, connections must be as per wiring diagram below.

1	Electronic box	6	charging cable, green	10	rev.counter cable, gray
2	eight lighting coils	7	charging cable, white	11	mass cable, brown
3	four charging coils	8	shorting cables, black/yellow	12	ignition cables
4	pickup	9	lighting cables, yellow-	13	spark plug connectors
5	trigger cable, red		yellow/black	14	spark plugs
				15	shrink tube

After installing, all the connections must be protected with the supplied shrink tubing.

◆ NOTE: Wiring diagram shows DCDI ignition.

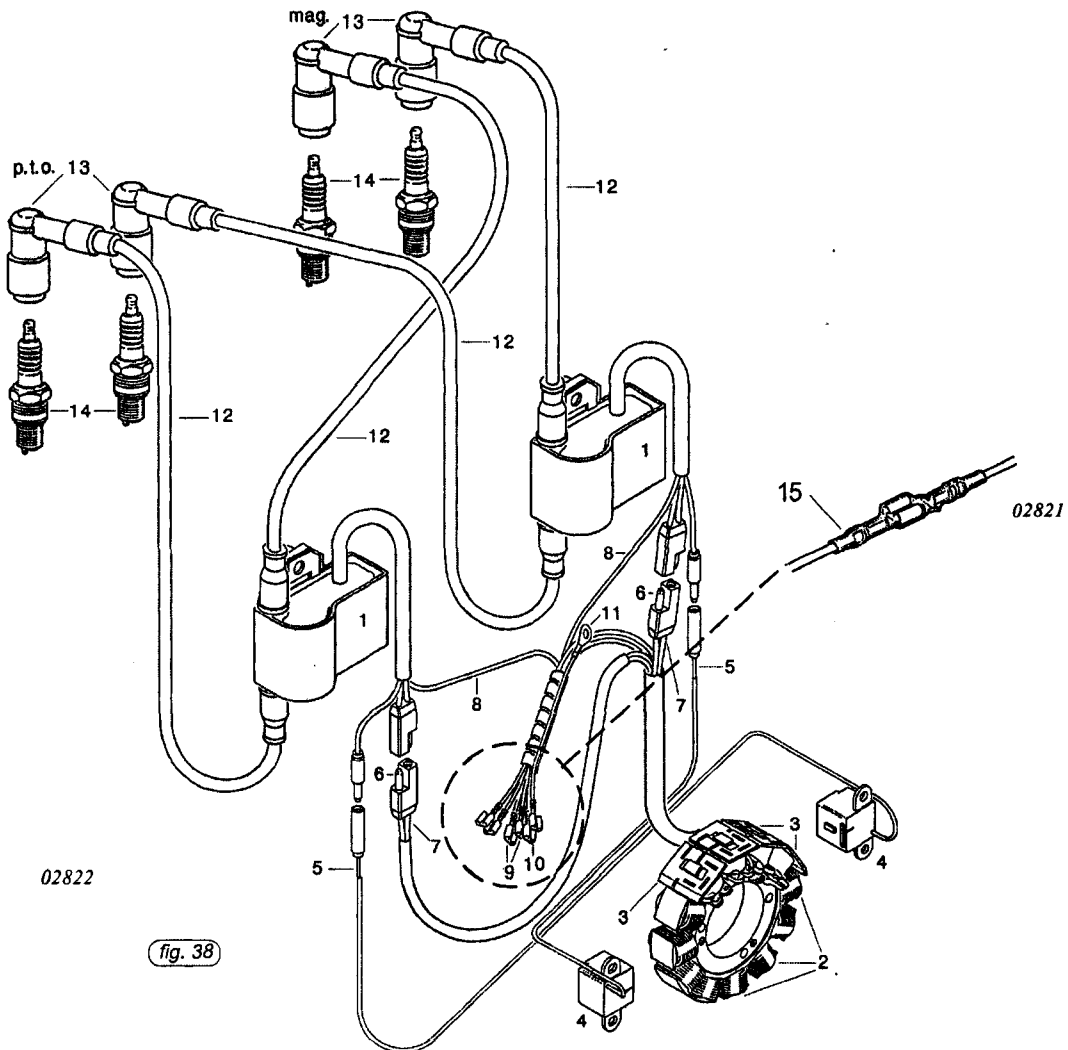

18.4) Lighting circuit:

In the stator 8 lighting coils are incorporated. The output is 170W A.C. at 6000 l/min. This alternating current can be used directly to feed A.C. consumers, or via a rectifier-regulator for loading a battery and feeding direct current consumers.

To avoid the voltage to rise above permissible levels, a voltage regulator must be used.

To operate loads requiring direct current (e.g. charging battery), a rectifier-regulator is required.

A rectifier-regulator, part no. 866 080, is available. As a power supply for lights only. This rectifier-regulator can be used without a battery. In this case the regulated RMS voltage will be between 11 and 12 Volts as long as a minimum load of 1 amp is provided.

If a battery is used it must be capable of absorbing approx. 1 amp. minimum continuous charging load, even with full charge (suggested minimum battery capacity: 9 amp.h, resp. 16 amp.h with electric starter). Regulated voltage is 13.5 to 14.5 volts.

When using 3-phase rectifier-regulator 264 870 no minimum load is required.

18.5) Technical Data and connection of components

18.5.1) Wiring diagram for rectifier regulator 866 080

■ Attention: To avoid excessive voltage in conjunction with the rectifier regulator 866080, a constant minimum ballast load of 1 amp is required (example: lamp 12 V 15 W).

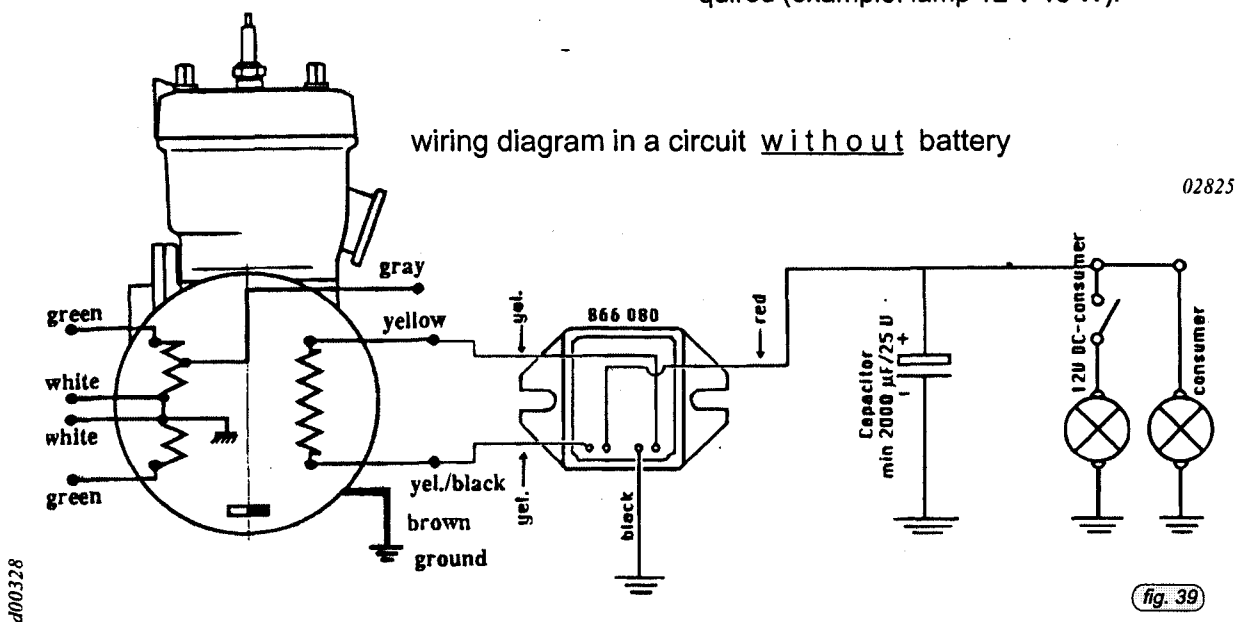

400328

ROTAX.
AIRCRAFT ENGINES
INSTALLATION MANUAL

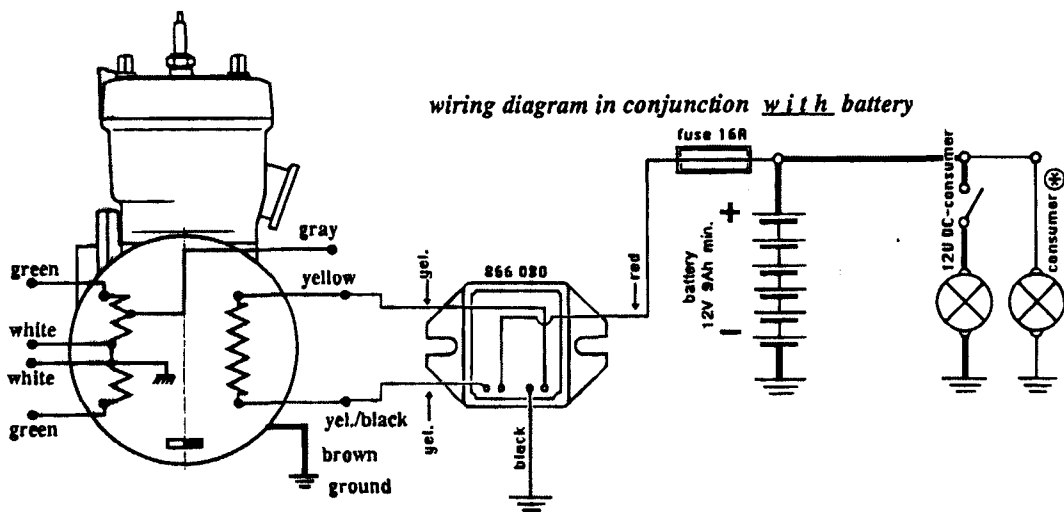

02824

fig. 40

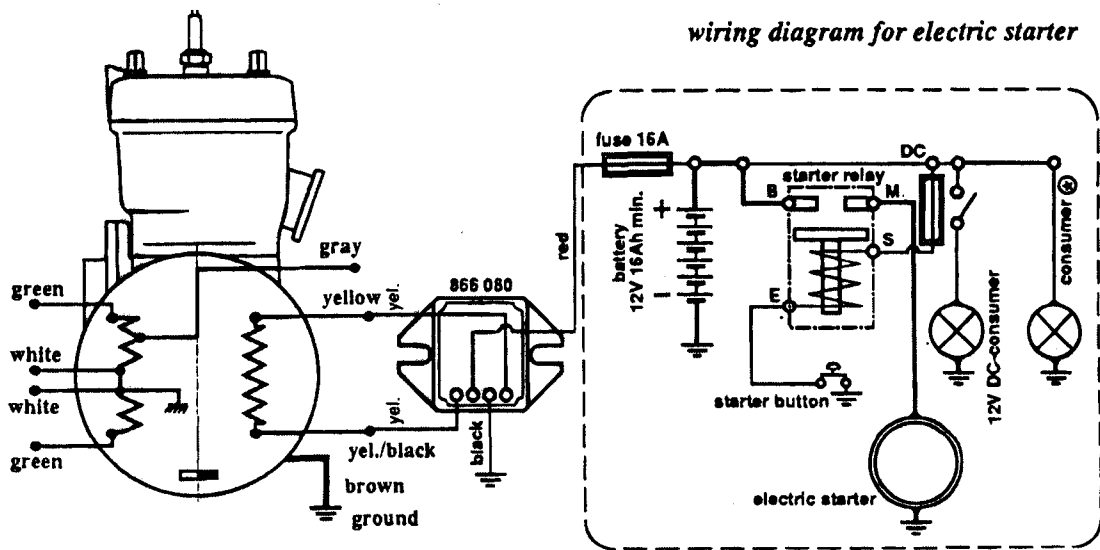

fig. 41

02823

400328

18.5.2) Wiring diagram for rectifier regulator 264 870 (not limited to minimum of 1 Ampere consumption)

wiring diagram in a circuit without battery

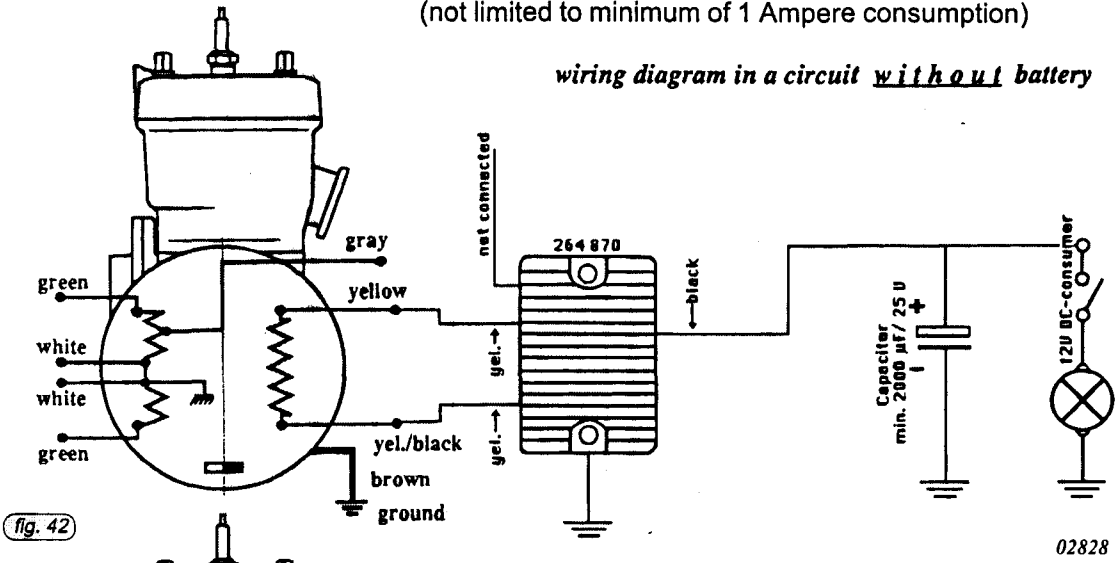

wiring diagram in conjunction with a battery

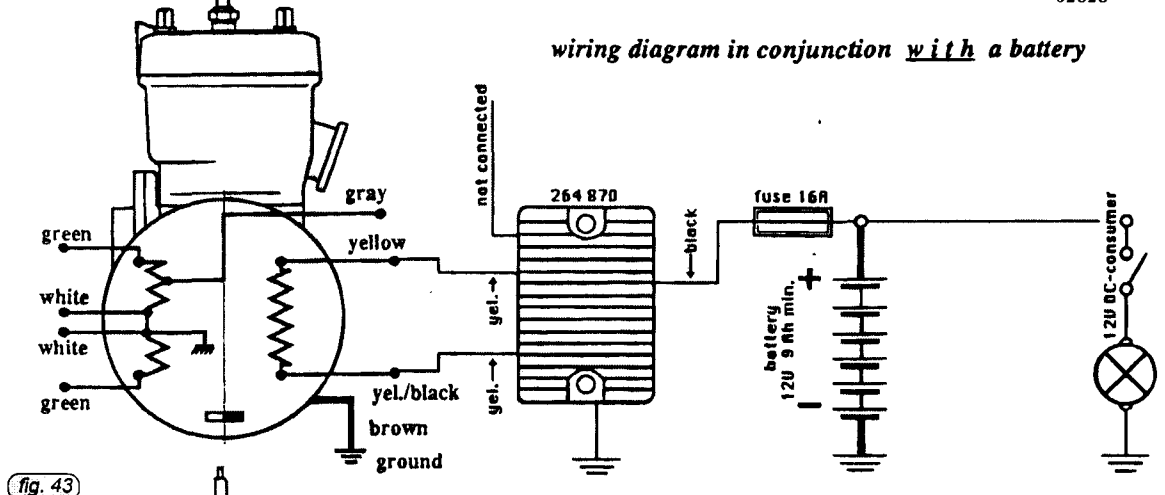

wiring diagram for electric starter

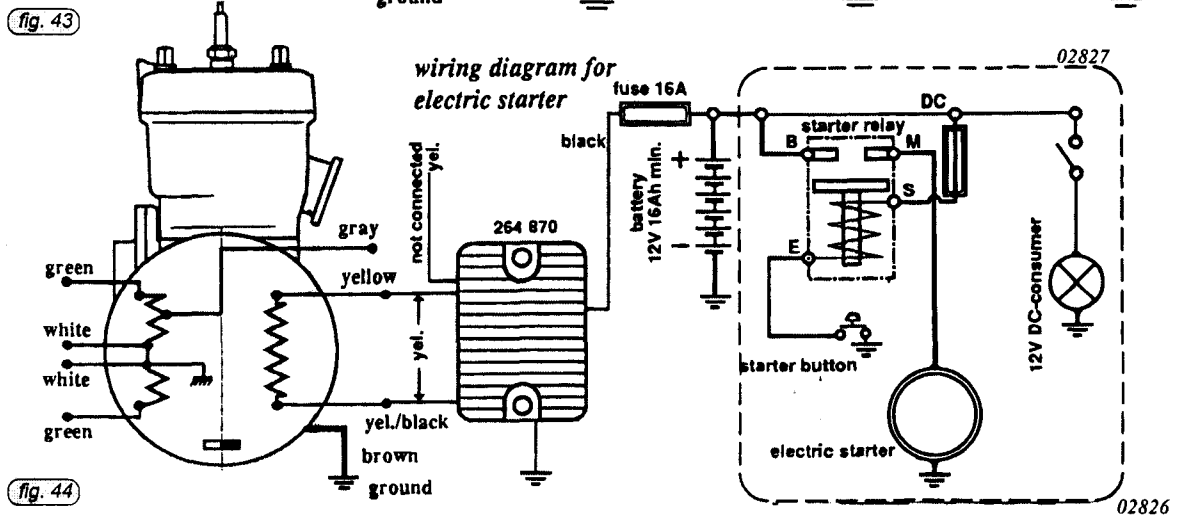

d00328



AIRCRAFT ENGINES

INSTALLATION MANUAL

18.5.3) Electronic revolution counter:

The revolution counter, part no. 966 404, has been specifically designed to be connected to the 12 pole flywheel generator used on the Ducati CDI Systems.

The revolution counter measures the frequency of the pulses provided by one of the transducers supply winding where it is connected. It does not require any external power supply. It is connected by two wires without polarity.

The indicating range is up to 8000 r.p.m. The weight is 235 gram.

Connection to dual ignition system:

02960

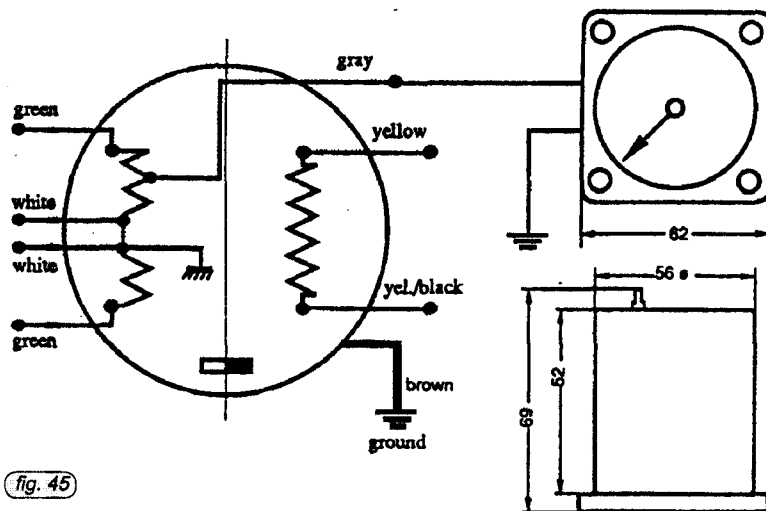

fig. 45

The generator integrated in the DUCATI dual ignition has a special gray cable for revolution counter connection. The revolution counter 966 404 must be fitted between the gray cable and mass (brown cable).

The tachometer will indicate correct RPM even if one of the two ignition systems is turned off for ignition testing procedure or a transducer failure occurs.

Maximum allowed deviation: +/- 100 1/min

d00328

18.5.4) Electric starter

Two types of electric starters can be fitted to ease starting procedures especially in flight.

Electric starter fitted on "E" type gearbox. There is also the possibility to use a rewind start.

Electric starter fitted on magneto side. However for use on engines utilizing a ROTAX gear reduction unit, this electric starter system prevents rewind starter application.

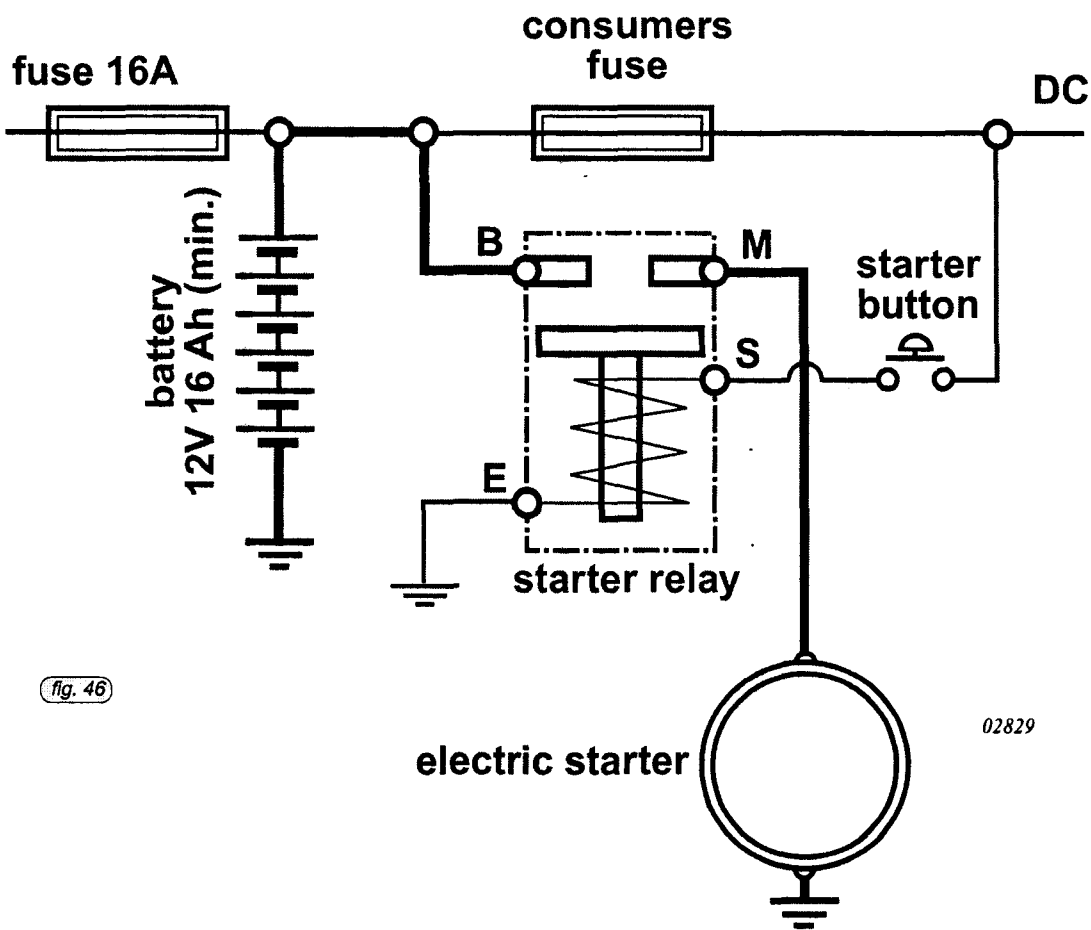

fig. 46

02829