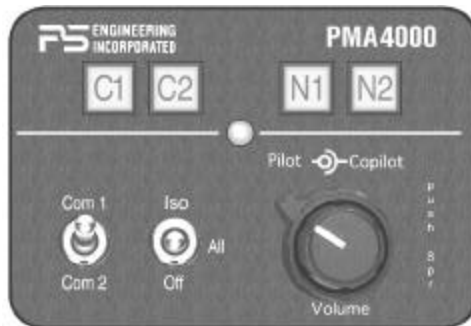


# PS ENGINEERING<sup>®</sup> INCORPORATED

*Sound Quality. Sound Engineering.*

9800 Martel Road  
Lenoir City, TN 37772

## **PMA4000 TSO** Audio Selector Panel *IntelliVox™* Intercom System *Installation and Operation Manual*



US Pat. No. 6,493,450

FAA TSO C50c

Document P/N 200-041-0001  
September 2002

**PS Engineering, Inc. ©2002**  
*Copyright Notice*

Any reproduction or retransmittal of this publication, or any portion thereof, without the expressed written permission of PS Engineering, Inc. is strictly prohibited. For further information contact the Publications Manager at PS Engineering, Inc., 9800 Martel Road, Lenoir City, TN 37772. Phone (865) 988-9800.

Table of Contents

<b>Section I GENERAL INFORMATION .....</b>	<b>1-1</b>
1.1 INTRODUCTION.....	1-1
1.2 SCOPE .....	1-1
1.3 EQUIPMENT DESCRIPTION.....	1-1
APPROVAL BASIS – FAA- TSO C50c.....	1-2
1.4 SPECIFICATIONS .....	1-2
1.5 EQUIPMENT SUPPLIED .....	1-3
1.6 Optional remote volume control (P/N 250-004-0020).....	1-3
1.7 Optional 2 ¼” mounting plate kit (250-004-0005).....	1-3
1.8 EQUIPMENT REQUIRED BUT NOT SUPPLIED .....	1-3
1.9 LICENSE REQUIREMENTS .....	1-4
<b>Section II -Installation .....</b>	<b>2-1</b>
2.1 GENERAL INFORMATION .....	2-1
2.1.1 SCOPE .....	2-1
2.2 Unpacking and Preliminary Inspection.....	2-1
2.3 Equipment Installation Procedures .....	2-1
2.3.1 Cooling Requirements .....	2-1
2.3.2 Mounting Requirements.....	2-1
2.3.3 Mounting Hole configuration.....	2-1
2.3.4 Connector Assembly.....	2-2
2.4 Cable Harness Wiring .....	2-2
2.4.1 Noise.....	2-2
2.4.2 Entertainment Input .....	2-3
2.4.3 Radio Push-to-Talk.....	2-3
2.4.4 Power and 28 VDC Dropping Resistor .....	2-4
2.4.5 Backlighting .....	2-4
2.4.6 Intercom.....	2-4
2.5 Adjustments.....	2-4
2.6 Panel Installation .....	2-5
2.7 Post Installation Checkout.....	2-5
2.7.1 Operational Checkout.....	2-5
2.8 Final Inspection.....	2-6
<b>Section III OPERATION .....</b>	<b>3-1</b>
3.1 SCOPE .....	3-1
3.2 Audio Selector.....	3-1
3.2.1 Intercom Mode Selector Switch .....	3-1
3.2.2 Speaker Amplifier .....	3-2
3.3 Mic Selector Switch.....	3-2
3.3.1 Volume Control .....	3-2

3.3.2	VOX-Squelch Control .....	3-3
3.3.3	Intercom Modes .....	3-3
3.3.4	Push to talk intercom mode .....	3-4
<b>Section IV- Warranty and Service .....</b>		<b>4-1</b>
4.1	Warranty .....	4-1
4.2	Factory Service.....	4-1
<b>Appendix A External PTT Hook Up.....</b>		<b>A</b>
<b>Appendix B- Installation Drawing and Connector Layout.....</b>		<b>B</b>
<b>Appendix C Unit Connector Wiring.....</b>		<b>C</b>
<b>Appendix D -Instructions for FAA Form 337 and Continuing Airworthiness.....</b>		<b>A</b>
<b>Appendix F RTCA DO160D (EUROCAE ED-14) Environmental Qualification Form</b>		<b>E</b>

Table of Figures

Figure 1-1	PMA4000 .....	1-2
Figure 3-1	PMA4000 .....	3-1
Figure 3-2	Mic Selector .....	3-2
Figure 6-1-	Hole Configuration.....	A
Figure 6-2	Hole Configuration to avoid rectangular cutouts.....	A
Figure 6-3	Connector Layout .....	B
Figure 6-4	Installation Diagram.....	B

Table of Tables

Table 3-1	Mic Muff <sup>TM</sup> Part Numbers .....	3-3
Table 3-1	Intercom Modes .....	3-4

## Section I GENERAL INFORMATION

### 1.1 INTRODUCTION

The PMA4000 TSO Audio Selector Panel is a right-sized solution for the audio switching needs of light aircraft. By combining basic audio selector panel, with PS Engineering's revolutionary *IntelliVox*® intercom, the aircraft owner can have audio panel functionality without an investment in panel space.

Before installing and/or using this product, please read this manual completely. This will ensure that you will take full advantage of all the advanced features.

### 1.2 SCOPE

This manual provides detailed installation and operation instructions for the PS Engineering PMA4000 TSO Audio Selector Panel/Intercom Systems. This includes the following unit:

<u>Model</u>	<u>Description</u>	<u>Part Number</u>
PMA4000 TSO	Audio Selector Panel	11942

### 1.3 EQUIPMENT DESCRIPTION

The PMA4000-series is a state of the art audio isolation amplifier and audio selector that contains an automatic voice activated (VOX) intercom system. It can switch two transceivers (Com 1, Com 2) and two receivers (Nav 1, Nav 2) In addition, there are four unswitched inputs, for additional audio requirements. Push buttons select the receiver audio source provided to the headphones. A SPR push-on switch on the volume control allows the user to listen to the receiver(s) selected on the cabin speaker. Except for the unswitched inputs, all speaker audio is muted during transmit. A toggle switch selects one of the two transceivers for the pilot and copilot positions in transmit.

A fail-safe mode connects the pilot headphone and microphone to COM 1 if power is removed for any reason, or if the Com Selector switch is in the "Off" position.

A 4-station voice activated (*IntelliVox*™) intercom is included in the PMA4000. Pilot isolate and ALL modes, a mono music input with "Soft Mute." A dual concentric knob pair controls pilot volume and copilot/passenger intercom volume.



**Figure 1-1 PMA4000**

## **APPROVAL BASIS – FAA- TSO C50c**

The PMA4000 Audio Selector Panels are FAA approved under TSO C50c (Audio Amplifiers).

**All systems comply with relevant portions of EUROCAE ED-14C/DO-160D (Environmental Conditions and Test Procedures for Airborne Equipment), ED12B/DO-178B (Software Considerations for Airborne Equipment) and ED- 18/DO-214 (Audio Systems Characteristics and Minimum Operational Performance Standards for Aircraft Audio Systems).**

Operation is subject to the following conditions:

1. This device may not cause harmful interference.
2. This device must accept any interference received, including interference that may cause undesired operation.

## **1.4 SPECIFICATIONS**

ENVIRONMENTAL Qualifications:	B1CABSRXXXXXXABBBBTMXXE2XXX
<i>Temperature Range:</i>	
Operating:	-20°C to +55°C
Storage:	-40°C to +85°C
<i>Altitude:</i>	Up to 25,000 feet in an unpressurized area of the cockpit.
<i>Audio Selector/Intercom:</i>	C50c, Class A
APPLICABLE DOCUMENTS:	RTCA/DO-214, RTCA/DO-160D
DIMENSIONS:	Height: 1.35 in. (3.4 cm) Width: 2.40 in. (6.1 cm) Depth: 6.50 in. (16.5 cm) behind panel
WEIGHT (With Connectors):	12.4 oz. (0.35 kg)
<i>Voltage:</i>	11 to 33 VDC (28 Volt w/dropping resistor)
<i>Maximum Current:</i>	1.5 Amp -Externally protected by a 3 Amp (14 VDC) or 2A (28V) breaker.
<i>Typical operating current:</i>	
Speaker off:	100 mA
Speaker on, 28V, full radio volume	250 mA
<b>Audio Selector Specifications</b>	
<i>Audio selector panel input impedance:</i>	510 Ω
<i>Input Isolation:</i>	-60 dB (min.)
<i>Speaker Muting:</i>	-60 dB (min.)
<i>Speaker Output (into 4 Ω) with no clipping</i>	
14 VDC:	2 Watts (min.)
28 VDC:	8 Watts (min.)
<i>Receiver Inputs:</i>	4 (Com 1, Com 2, Nav 1, Nav 2)
<i>Unswitched Inputs:</i>	4 (examples: ADF, DME, GPS WPT, Marker, Autopilot Disconnect, Altimeter DH)
<i>Transmitter Selections:</i>	2 (Com 1, Com 2)
<i>Speaker Impedance:</i>	4 Ω
<i>Headphone Impedance:</i>	150 – 1000 Ω
<i>Headphone Output:</i>	30 mW each headset, with < 10% THD into 150Ω
<i>Microphone Impedance:</i>	150 - 600 Ω
<b>Intercom Specifications</b>	
<i>Intercom Positions:</i>	4 places (with individual IntelliVox® circuits)
<i>Music Input:</i>	1 (Monaural)

**PS Engineering**  
PMA4000 TSO Series Audio Selector Panel and Intercom System  
Installation Manual

<i>Music Muting:</i>	>30 dB "Soft Mute"
<i>Distortion:</i>	<1% THD @ 30 mW into 150Ω
<i>Mic Freq. Response, ±3 dB:</i>	300 Hz - 6000 Hz
<i>Music Freq. Response, ± 3 dB:</i>	100 Hz - 18kHz

## 1.5 EQUIPMENT SUPPLIED

A. 1 ea. of the following units:

	Part Number
PMA4000 TSO	11942

B. PMA4000 Installation Kit: 250-0041-0001

Part Number	Description	Quantity
575-004-0005	Faceplate (Square)	1
475-632-0006	Mounting Screws 6-32X3/8" Phil-Pan Black	2
625-002-0001	Knob, outer	1
625-002-0004	Knob, inner	1
625-010-0002	Knob insert pointer	1
425-025-0005	Connector, 25-pin, male	1
425-025-0006	Connector, 25-pin, female	1
701-015-1501	Dropping Resistor, 15 Ω, 15 Watt, (required in 28 VDC installation)	1
475-002-0002	Connector Thumbscrews	4
625-025-0001	Connector Hood	2
430-400-0028	Mounting Shim - 0.028 in	1
430-400-0050	Mounting Shim - 0.050 in.	1
200-041-0000	Operator's and Installation Manual	1

## 1.6 Optional remote volume control (P/N 250-004-0020)

This kit contains:

1 ea. 10KΩ Potentiometer P/N 675-020-0103

1 ea. knob, Black 1/4" Shaft w/Set Screw P/N 625-020-0005

## 1.7 Optional 2 ¼" mounting plate kit (250-004-0005)

This kit contains:

1 ea. 2 ¼" Mounting plate for instrument hole mounting, P/N 575-004-0001

1 ea. Mounting Shim, 430-400-0090

## 1.8 EQUIPMENT REQUIRED BUT NOT SUPPLIED

- A. Speaker, 4 Ω
- B. Headphones, 150 Ω mono, up to 4 as required
- C. Microphones, up to 4 as required
- D. Interconnect Wiring
- E. Headphone Jacks (As Required)
- F. Microphone Jacks (As Required)
- G. Circuit Breaker: 1 ea. 3 amp.

## **1.9 LICENSE REQUIREMENTS**

None

## **Section II -Installation**

### **2.1 GENERAL INFORMATION**

#### **2.1.1 SCOPE**

This section provides detailed installation and interconnect instructions for the PS Engineering PMA4000-TSO Series Audio Selector Panel/Intercom System.

Please read this manual carefully before beginning any installation to prevent damage and post installation problems. Installation of this equipment requires special tools and knowledge. The equipment **must** be installed by an appropriately rated Certified Aircraft Repair Station, in accordance with applicable regulations.

#### **2.2 Unpacking and Preliminary Inspection**

Use care when unpacking the equipment. Inspect the units and parts supplied for visible signs of shipping damage. Examine the unit for loose or broken buttons, bent knobs, etc. Verify the correct quantity of components supplied with the list in Section 1.6 (B). If any claim is to be made, save the shipping material and contact the freight carrier. Do NOT return units damaged in shipping to PS Engineering. If the unit or accessories shows any sign of external shipping damage, contact PS Engineering to arrange for a replacement. Under no circumstances attempt to install a damaged unit in an aircraft. Equipment returned to PS Engineering for any other reason should be shipped in the original PS Engineering packaging, or other UPS approved packaging.

#### **2.3 Equipment Installation Procedures**

##### **2.3.1 Cooling Requirements**

Forced-air cooling of the PMA4000 is not required. However the unit should be kept away from heat producing sources (i.e. defrost or heater ducts, dropping resistors, heat producing avionics) without adequate cooling air provided.

##### **2.3.2 Mounting Requirements**

The PMA4000 must be rigidly mounted to the instrument panel of the aircraft structure and within view and reach of the pilot position(s). Installation must comply with FAA Advisory Circular AC 43.13-2A. The unit may be mounted in any area where adequate clearance for the unit and associated wiring bundle exist.

##### **2.3.3 Mounting Hole configuration**

For instrument panel mounting, make openings in the panel according to the templates and drawing supplied. Depending on the instrument panel thickness, you may elect to use the shim



supplied for the best button depth and mechanical contact. See Appendix B for mounting hole layout.

### **2.3.4 Connector Assembly**

The unit connectors are DB25 type. The unit has a male (bottom) a female (top), to prevent incorrect connections. The top connector is generally the output, and the bottom connector is generally the input connections.

## **2.4 Cable Harness Wiring**

Referring to Appendix C, assemble a wiring harness as required for the installation. All wires must be MIL-SPEC in accordance with current regulations. Two- and three-conductor with shield wire must be used where indicated, and be MIL-C-27500 or equivalent specification. Proper stripping, shielding and soldering technique must be used at all times. **It is imperative that the correct wire and techniques be used for proper operation.**

The shield should not be used as ground return. Terminate the shields with a short jumper to the appropriate pin as shown in Appendix C, as close to the unit connector as practical.

Refer to FAA Advisory Circular 43.13-2A for more information. Failure to use correct techniques may result in improper operation, electrical noise or unit failure. **Damage caused by improper installation will void the PS Engineering warranty.**

### **2.4.1 Noise**

Due to the variety and the high power of radio equipment often found in today's general aviation aircraft, there is a potential for both radiated and conducted noise interference.

The PMA4000 power supply is specifically designed to reduce conducted electrical noise on the aircraft power bus by at least 50dB. Although this is a large amount of attenuation, it may not eliminate all noise, particularly if the amplitude of noise is very high. There must be at least 13 VDC present at the bottom connector, pin 13, of the PMA4000 for the power supply to work in its designed regulation. Otherwise, it cannot adequately attenuate power line noise. Shielding can reduce or prevent radiated noise (i.e., beacon, electric gyros, switching power supplies, etc.) However, installation combinations can occur where interference is possible. The PMA4000s were designed in a RFI hardened chassis and have internal Electromagnetic Interference (EMI) filters on all inputs and outputs.

Ground loop noise occurs when there are two or more ground paths for the same signal (i.e., airframe and ground return wire). Large cyclic loads such as strobes, inverters, etc., can inject noise signals onto the airframe that are detected by the audio system. Follow the wiring diagram very carefully to help ensure a minimum of ground loop potential. Use only Mil Spec shielded wires (MIL-C-27500, or better).

Radiated signals can be a factor when low level microphone signals are "bundled" with current carrying power wires. Keep these cables physically separated. It is very important that you use

insulated washers to isolate the ground return path from the airframe to **all** headphone and microphone jacks.

## 2.4.2 Entertainment Input

A single entertainment device (CD player, cassette player, etc.) can be connected to the unit. Install a 1/8-inch stereo jack in a convenient location so that the pilot can plug in the entertainment device into the system.

For a stereo input, we recommend tying the left and right channels (tip and ring) together, so both stereo channels are provided to the monaural audio panel, and the audio amplitude available to the audio panel is increased. Audio signal at the entertainment input must be a minimum of 1V P-P for optimum music performance. We have noticed that the portable devices using 4 batteries seem to work better than the 2-cell types. Also we have found that some cigarette-lighter adapters introduce noise into the system due to the voltage switching power supply.

### 2.4.2.1 Soft Mute

The PMA4000-system incorporates a "Soft Mute" system. This will mute the entertainment devices during ICS or radio traffic. The entertainment input (P2, pin 25 and 13) is heard by everyone (except by the pilot in ISO mode).

**NOTE:** The Soft Mute Enable switch is connected between P2, Pin 5 and ground. When this pin is grounded, the soft mute is inactive, and the PMA4000 is in "Karoake" Mode.

Local oscillators and internal signals from some entertainment equipment can cause undesired interference with other aircraft systems. Before takeoff, operate the entertainment devices to determine if there is any adverse effect within the aircraft systems. If any unusual operation is noted in flight, immediately switch off the entertainment devices.

**NOTE:** Use the low-level output of any entertainment device to connect to the audio panel. Maximum signal level is **3 VAC** p-p. **DO NOT** use a speaker-level output, this will cause internal damage in the audio panel.

To use a speaker level, install an AudioLink adapter (part number 101PL2), available from Crutchfield at 1-800-955-3000

## 2.4.3 Radio Push-to-Talk

An important part of the installation is the PTT (Push-To-Talk) switches that allow the use of your aircraft communications radio for transmissions. There are three typical configurations that can be used. Select the case that best fits the installation. Only the person who presses their PTT switch will be heard over the radio. If the pilot and copilot both use the PTT, the copilot position has access to the radio. The pilot position will have PTT control regardless of the copilot when the PMA4000 is in the FAIL-SAFE mode.

*CASE I:* PTT is built into both pilot and copilot yokes.

*CASE II:* PTT is in pilot yoke only. This configuration requires a modified external PTT switch plugged into the copilot's microphone jack. (See Appendix A). When the copilot's PTT is pressed, the intercom switches the mic audio from pilot to copilot mic.

*CASE III:* No built in PTT. This requires two built in PTTs to be installed, or modified external PTT switches to be used. Modify external PTT as required (See Appendix A).

#### **2.4.4 Power and 28 VDC Dropping Resistor**

The PMA4000 is compatible with both 13.8 and 28 Volt DC systems. A three (3) Amp circuit breaker is required. Power and ground wires must be a twisted #18 AWG pair.

If installed in a 28V aircraft, a 15 $\Omega$ , 15 watt dropping resistor must be installed in the power input.

#### **2.4.5 Backlighting**

The PMA4000 has automatic lamp dimming of the buttons controlled by a photo-resistor. The photocell located at the center of the unit face will automatically adjust the intensity of the push-button lamps.

#### **2.4.6 Intercom**

All mic and headphone jacks must have insulating washers, the cable must be Teflon coated, twisted-shielded wire, and the shield must only be connected to the ground return wire **only** at the intercom connector. NOTE: This harness can be custom made by PS Engineering, Inc. Simply call the factory (1-800-ICS-AERO) and obtain a wire harness work-sheet. Or obtain at websiteThe harness will be made to your specifications and fully functionally tested. All hardware is included.

##### **2.4.6.1 Push-to-talk intercom**

PMA4000 units include a push-to-talk intercom capability. In some extremely high noise environments, it may be desirable to have a push to talk (PTT) intercom, instead of relying on voice-activation (*IntelliVox*<sup>TM</sup>).

To operate the PTT, simply ground P2, Pin 16 (PTT Enable) through a switch. Then, grounding the appropriate pin on the P2 connector through a momentary switch (Pin 4 for the pilot, Pin 17 for copilot) will open only that intercom channel. The passengers do not have PTT capability. Their *IntelliVox*<sup>TM</sup> remains active when the ICS PTT enable is grounded. If PTT is desired for the passenger position, add a momentary, normally open (NO) switch in series with the mic audio input to P2, pin 14 and 15.

#### **2.5 Adjustments**

The PMA4000 is factory adjusted to accommodate the typical requirements for most aircraft configurations. There is an adjustment for the cabin speaker volume, accessed

through the left side (viewed from the front) of the unit. To make the necessary adjustments, use a small jeweler's slotted screwdriver. Turning the adjustment counter clockwise will increase the volume.

## **2.6 Panel Installation**

1. Insert the PMA4000 from behind the instrument panel.
2. Use caution when aligning the holes for the knobs, toggle switches and push-buttons.
3. If necessary, add the shim spacers between the unit and the back side of the instrument panel, so the selector buttons are the correct depth for the shoulder of the switch to mate with the front plate.

**Note: The total panel thickness should be about 0.100" Add the necessary shims to come as close to 0.100" as possible. For instance, a .050" instrument panel, add a .050" shim.**

4. Carefully place the aluminum face-plate over the knob shafts and push-buttons, seating the push-button shoulders in the panel.
5. Secure the unit, using the two # 6-32 round head screws provided.
6. Install the knobs over the volume control shaft.

### **2.6.1.1 Instrument hole mounting**

The PMA4000 can be mounted in a 2 ¼-inch instrument hole, using the adapter plate, part number 575-004-0001 (not supplied).

1. Insert a .090" shim (430-400-0090, not supplied) between the PMA4000 and the mounting plate. Use caution to align the selector buttons in the openings.
2. Secure the mounting plate to the unit and shim assembly with the two # 6-32 round head screws provided. Use caution to align the selector buttons in the openings
3. Mount the intercom and plate to the instrument panel from behind, using aircraft instrument hardware, not supplied.
4. Install the knobs over the volume control shafts.

## **2.7 Post Installation Checkout**

After wiring is complete, verify aircraft power is ONLY on pin 13 of the bottom connector, and airframe ground on bottom connector pin 25. Failure to do so will cause serious internal damage and void PS Engineering's warranty.

To avoid stray voltages, the other avionics should be turned off.

### **2.7.1 Operational Checkout**

1. Apply power to the aircraft and avionics.
2. Plug headsets into the pilot, copilot and passenger positions.
3. Place the Mic Selector Switch to the Com 1 position.

4. Verify that the C1 light comes on. If the push-button is flashing, stop testing and troubleshoot the microphone PTT installation. A flashing indicator in the COM select button indicates that the key line is grounded.
5. Verify proper transmit and receive operation on the pilot and copilot positions, noting that the PTT switches allows proper transmission on the selected transceiver.
6. Verify that the button blinks when the selected transmitter is active.
7. Verify that switching to the C2 position causes the button to illuminate and the Com 2 receiver to be heard. Verify transmit and receive on Com 2.
8. Press the Com 1 push button, and verify that Com 1 and Com 2 receive audio can be heard.
9. Verify proper operation of the Nav 1 and Nav 2 receiver sources by selecting them using the N1 and N2 buttons. Note that the button for the receiver sources stays in, and the button illuminates to show which source is in use.
10. Push in volume control to activate the speaker (SPR) switch. Verify that all selected audio is heard in the cockpit speaker. Verify that the audio mutes when the mic is keyed.
11. Verify proper Intercom system operation in the ALL, and ISO modes.
12. Verify that the audio selector panel system does not adversely affect any other aircraft system by systematically switching the unit on and off, while monitoring the other avionics and electrical equipment on the aircraft.

## **2.8 Final Inspection.**

Verify that the wiring is bundled away from all controls and no part of the installation interferes with aircraft control operation. Move all controls through their full range while examining the installation to see that no mechanical interference exists. Verify that the cables are secured to the aircraft structure in accordance with good practices, with adequate strain relief. Ensure that there are no kinks or sharp bends in the cables. Verify that the cables are not exposed to any sharp edges or rough surfaces, and that all contact points are protected from abrasion. Complete log book entry, FAA Form 337, weight and balance computation and other documentation as required. Return completed warranty registration application to PS Engineering.

## Section III OPERATION

### GENERAL INFORMATION

#### 3.1 SCOPE

This section provides detailed operating instructions for the PS Engineering PMA4000 TSO Audio Selector Panel/Intercom Systems. Please read it carefully before using the equipment so that you can take full advantage of its capabilities.

This section is divided into three sections covering the basic operating areas of the PMA4000 systems. They are: Audio Selector, Transceiver Selection and Intercom.

#### 3.2 Audio Selector



Figure 3-1 PMA4000

Through the use of four latched, push-button, back-lit switches, it is possible to select any or all receiver audio.

When selected, an internal backlight will illuminate indicating which audio source is selected. The Com toggle switch controls what transceiver is being heard by the pilot and copilot. "C1" (Com 1) and "C2" (Com 2) push-buttons select the receiver, and are used to monitor a com that is not selected for transmit. You will always hear the audio from the transceiver that is selected by the 2-position mic selector toggle switch.

The users can identify which receivers are selected by noting which push-button switches are illuminated. Push buttons labeled N1 (Nav 1), N2 (Nav 2) are "latched" type switches. When one of these buttons is pressed, it will stay in the "in" position. Press the switch again and it be in the "out" position and remove that receiver from the audio. While selected, the switch will also be annunciated by an internal lamp.

##### 3.2.1 Intercom Mode Selector Switch



Unit power is turned on and off by the mode selector switch. In the OFF or "FAIL-SAFE" position, the pilot is connected directly to Com 1 allowing transmit and receive capability regardless of unit condition. Any time power is removed or turned OFF, the audio selector will be placed in the fail-safe mode. The switch is a 3-position mode switch that allows the pilot to tailor the intercom function to best meet the situation.

**ISO:** (Up Position): The pilot is isolated from the intercom and is connected only to the aircraft radio. He will hear the aircraft radio reception (and sidetone during radio transmissions if provided by the transceiver). Copilot and passengers will hear the intercom and music on Entertainment input, but not the aircraft radio receptions or pilot transmissions.

**ALL:** (Middle Position): All parties will hear the aircraft radio, intercom, and music from entertainment input. However, during any intercom communications, the music volume automatically decreases when SoftMute is active. The music volume increases gradually back to the original level after communications have been completed.

### 3.2.2 Speaker Amplifier

Pressing the volume control will activate the cockpit speaker. This switch will place all selected audio on the cockpit speaker when selected. The speaker is automatically muted when the radio push to talk (PTT) is active. To reduce power consumption and internal heat buildup, switch off the speaker amplifier when not in use.

### 3.3 Mic Selector Switch



**Figure 3-2 Mic Selector**

The up switch position COM 1. Both pilot and copilot will be connected to the Com 1 transceiver. While in the COM 1 or COM 2 mode, the intercom functions normally. Both the pilot and copilot have transmit capabilities on the selected transceiver. All hear the selected audio if the intercom is in the ALL mode. Only the person who presses their Push To Talk (PTT), will be heard over the aircraft radio. Placing the toggle switch in the COM 2 position will place pilot and copilot on Com 2.

The PMA4000-Series has an automatic selector mode. Audio from the selected transceiver is automatically heard in the headsets and speaker (when selected). You can check this function by switching from COM 1 to COM 2 and watch the selected audio light on the selector change from C1 to C2. This ensures the pilot will never transmit on a radio is not listening to.

When switching from COM 1 to COM 2 while Com 2 has NOT been selected, Com 1 audio will be switched off. In essence, switching the mic selector will not effect the selection of Com receiver audio.

#### 3.3.1 Volume Control

The pilot volume control knob adjusts the loudness of intercom and music in the pilot's headphones only. It has no effect on selected radio audio levels. The copilot volume control adjusts the loudness of the intercom and music in the copilot headset. The passenger volume is also adjusted by the copilot volume control. Most general aviation headsets have a built-in volume control, so volume can be adjusted "locally." The copilot volume control is also controllable through the rear connector, so a tandem aircraft can adjust the volume from a different location.



### 3.3.2 VOX-Squelch Control

The PMA4000 incorporates PS Engineering's revolutionary *IntelliVox™*. No adjustment of the squelch control is required. Through two individual signal processors, the ambient noise appearing in all four microphones is constantly being sampled. Non-voice signals are blocked. When someone speaks, only their microphone circuit opens, placing their voice on the intercom.

The system is designed to block continuous tones, therefore people humming or whistling in monotone may be blocked after a few moments.

For best performance, the headset microphone must be placed within ¼ inch of your lips, preferably against them. It is also a good idea to keep the microphone out of a direct wind path. Moving your head through a vent air stream may cause the *IntelliVox™* to open momentarily. This is normal.

For optimum microphone performance, PS Engineering, Inc. recommends installation of a Microphone Muff Kit from Oregon Aero (1-800-888-6910). This will not only optimize VOX performance, but will improve the overall clarity of all your communications.

**Table 3-1 Mic Muff™ Part Numbers**

Manufacturer	Model	Mic Muff™ Part Number
Bose	Dynamic	90010
	Electret	90015
	M87 Dynamic	90020
David Clark	H10-30	90010
	H10-20, H10-40	90015
	H10-13.4	90015
Lightspeed	15K & 20K	90015
Peltor	7003	90010
	7004	90015
Pilot	11-20 & 11-90	90015
Sennheiser		90015
Telex	Airman 750	90015
	AIR3000	90010

### 3.3.3 Intercom Modes

The audio selector panel has provisions for an entertainment input device.

While in the ISO (Isolate) mode, only the copilot and the four passengers will hear entertainment device. In normal operation, whenever a person speaks or if the aircraft radio becomes active, the music will automatically mute and then will gradually return to the original listening level when the radio or intercom activity ceases.

If a stereo entertainment device is used, the left and right channels can be combined in the plug to provide full sound.



**Table 3-1 Intercom Modes**

<b>Mode</b>	<b>Pilot Hears</b>	<b>Copilot Hears</b>	<b>Passenger Hears</b>	<b>Comments</b>
<b>Isolate</b>	A/C Radio Pilot Sidetone (during radio transmission, if provided by aircraft radio)	Copilot and passenger intercom Entertainment	Passenger and Copilot intercom Entertainment	This mode allows the pilot to communicate with the air traffic control without the copilot or passengers bothered by the conversations. Copilot and passengers can continue to talk and listen to music
<b>All</b>	Pilot Copilot A/C Radio Passengers Entertainment	Copilot Pilot A/C Radio Passengers Entertainment	Passengers Pilot Copilot A/C Radio Entertainment	This mode allows all on board to hear radio reception as well as communicate on the intercom. Music and intercom is muted during intercom and radio communications

### 3.3.4 Push to talk intercom mode

In some extremely high noise environments, it may be desirable to have a push to talk (PTT) intercom, instead of relying on voice-activation (VOX). In the PMA4000 audio panel the PTT intercom capability is added. To operate the PTT, Activate the panel-mounted VOX override switch. Then, the ICS PTT switch on the pilot or copilot side will allow voice on the intercom.

## **Section IV- Warranty and Service**

### **4.1 Warranty**

In order for the factory warranty to be valid, the installations in a certified aircraft must be accomplished by an FAA- certified avionics shop and authorized PS Engineering dealer. An FAA Form 337 must also be accompanied by the warranty card for this warranty to be in effect. If the unit is being installed in an experimental aircraft by the owner/builder, a factory-made harness must be installed for the warranty to be valid.

PS Engineering, Inc. warrants this product to be free from defect in material and workmanship for a period of one (1) year from the date of installation. PS Engineering, Inc., at its option, will send a replacement unit at our expense if the unit should be determined to be defective after consultation with a factory technician.

This warranty is not transferable. Any implied warranties expire at the expiration date of this warranty. PS Engineering SHALL NOT BE LIABLE FOR INCIDENTAL OR CONSEQUENTIAL DAMAGES. This warranty does not cover a defect that has resulted from improper or unreasonable use or maintenance as determined by us. This warranty is void if there is any attempt to disassemble this product without factory authorization. This warranty gives you specific legal rights, and you may also have other rights which may vary from state to state. Some states do not allow the exclusion of limitation of incidental or consequential damages, so the above limitation or exclusions may not apply to you.

### **4.2 Factory Service**

The unit is covered by a one-year limited warranty. See warranty information. Contact PS Engineering, Inc. at (865) 988-9800, or at [www.ps-engineering.com](http://www.ps-engineering.com) before you return the unit. This will allow the service technician to provide any other suggestions for identifying the problem and recommend possible solutions.

After discussing the problem with the technician and you obtain a Return Authorization Number, ship product to:

Note: PS Engineering will not be responsible for units shipped in US Mail.

Service Department  
PS Engineering, Inc.  
9800 Martel Rd  
Lenoir City, TN 37772  
Phone (423) 988-9800  
FAX (423) 988-6619  
Email: [intercoms@ps-engineering.com](mailto:intercoms@ps-engineering.com)

## **Appendix A**

### **External PTT Hook Up**

Part of the installation includes the installation of PTT (Push To Talk) switches that allow the use of your aircraft radio for communications transmissions.

There are three configurations that can be used; you must select the case that best fits your installation. NOTE: Only the person who presses their PTT switch will be heard over the radio.

#### **CASE I**

*The PTT is built into the pilot and copilot yokes*

Simply install the plugs from the headset into the aircraft headphone jacks. Then use the yoke mounted PTT to transmit. No other action is required.

#### **CASE II**

*Built in PTT only on the pilot side only*

This configuration requires a modified external PTT switch plugged into the copilot's mic jack. (See Details Below) When the copilot's PTT is depressed, this activates an internal relay that switches the mic audio to the aircraft radio from the pilot to the copilot.

#### **Case III**

*No built in PTT switch at all.*

Two built-in PTT must be installed, or two external, modified PTT switches will be required for both the pilot and copilot. Modifications to the PTT are required. (See details below)

<b>Push To Talk Modifications</b>
-----------------------------------

When received from the manufacturer, an after-market PTT switch opens the mic audio path to the "ring" connection of the PTT mic plug until the button is pressed. When the PTT is between the intercom and the headset, the intercom function will not work unless the PTT switch is depressed. A simple modification can be performed to allow proper intercom operation. NOTE: This mod does not alter normal operation.

Below are some examples of typical modifications. Contact PS Engineering or the PTT manufacturer for more details if necessary.

#### **Procedures For David Clark PTT**

1. Unscrew the round black plastic cover from the jack.
2. Connect the joined black wires to the red wire.
3. Replace the round black plastic cover.

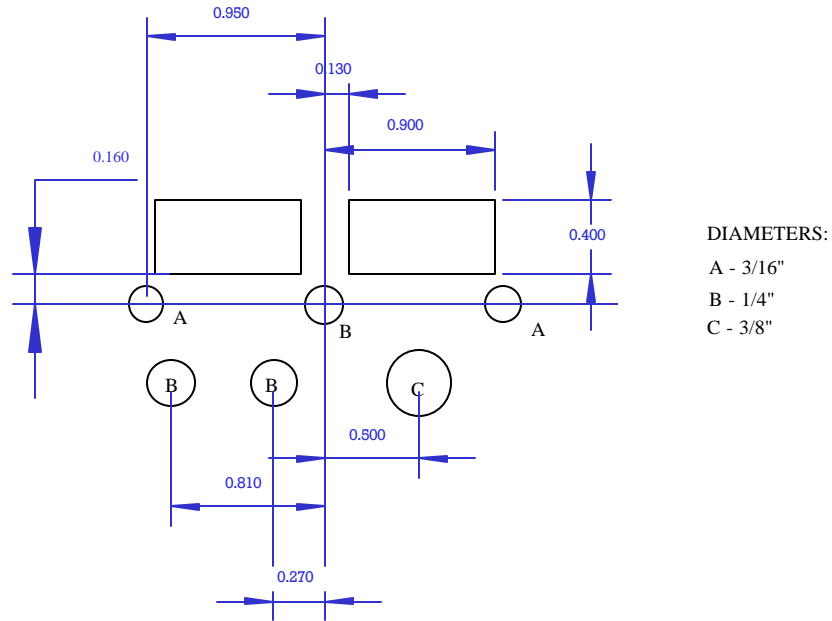
#### **Procedures for Telex PT-200**

1. Unscrew the round black plastic cover from the jack.
2. Cut the red wire in the middle of the wire.
3. Strip both ends of the insulation.
4. Solder the two ends to the ground lug to the PTT jack.
5. Replace the round black plastic cover.

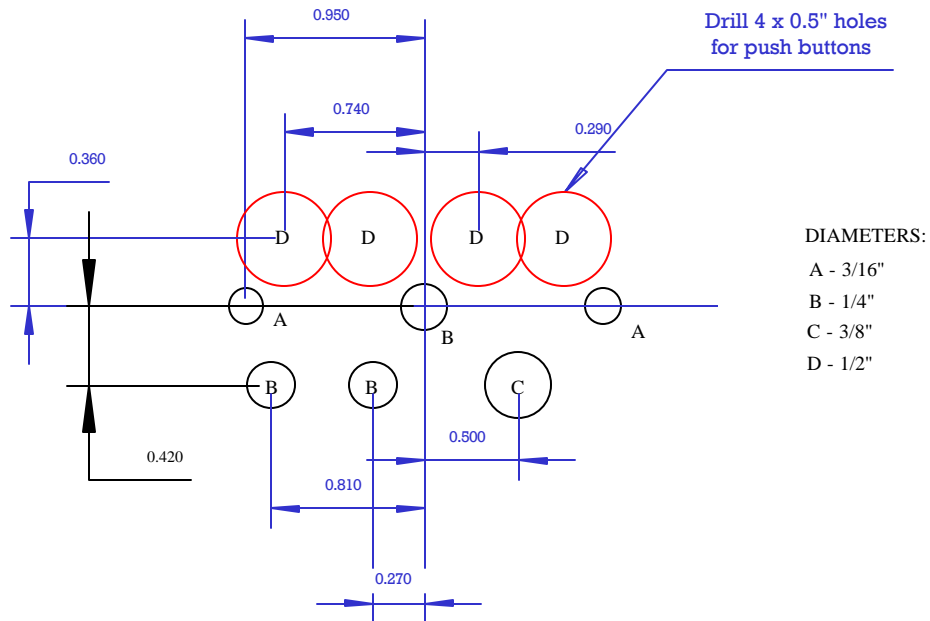
#### **Procedures for Telex PT-300**

1. Unscrew the round black plastic cover from the plug jack.
2. Remove the heat shrink material from the joined black wires.
3. Solder these two wires to the lug that has a white wire already soldered to it.
4. Replace the round black plastic cover

## Appendix B- Installation Drawing and Connector Layout



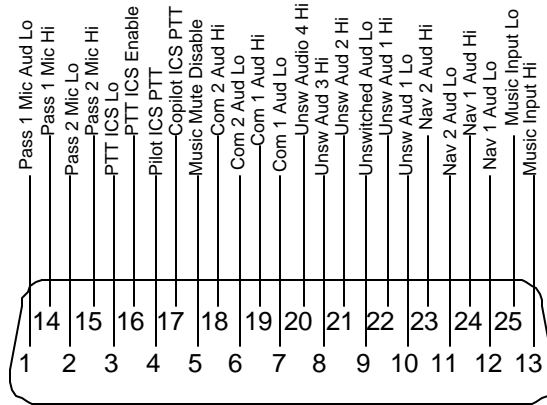
**Figure 6-1- Hole Configuration**



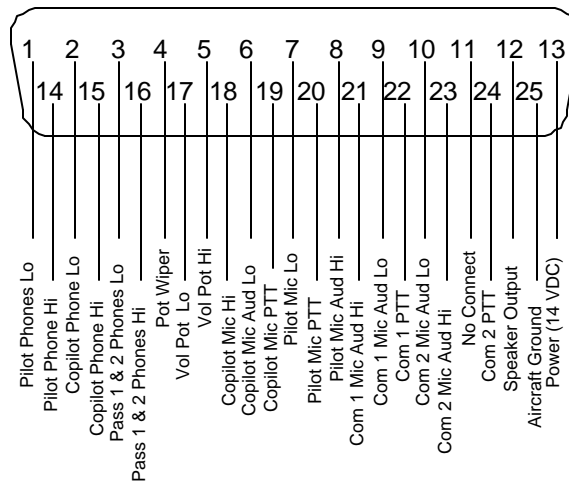
**Figure 6-2 Hole Configuration to avoid rectangular cutouts**

By pre-drilling pilot holes, and then drilling 1/2" holes as shown, the installer can avoid nibbling and filing a square opening.

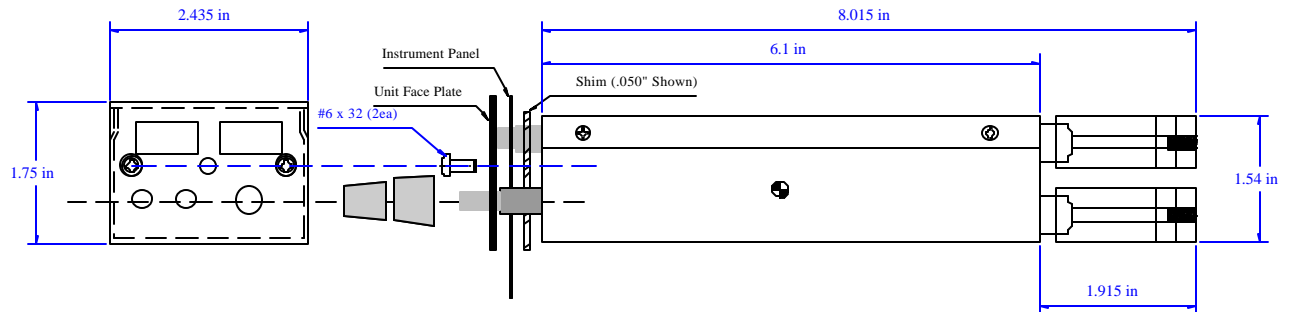
# Top Connector



# Bottom Connector

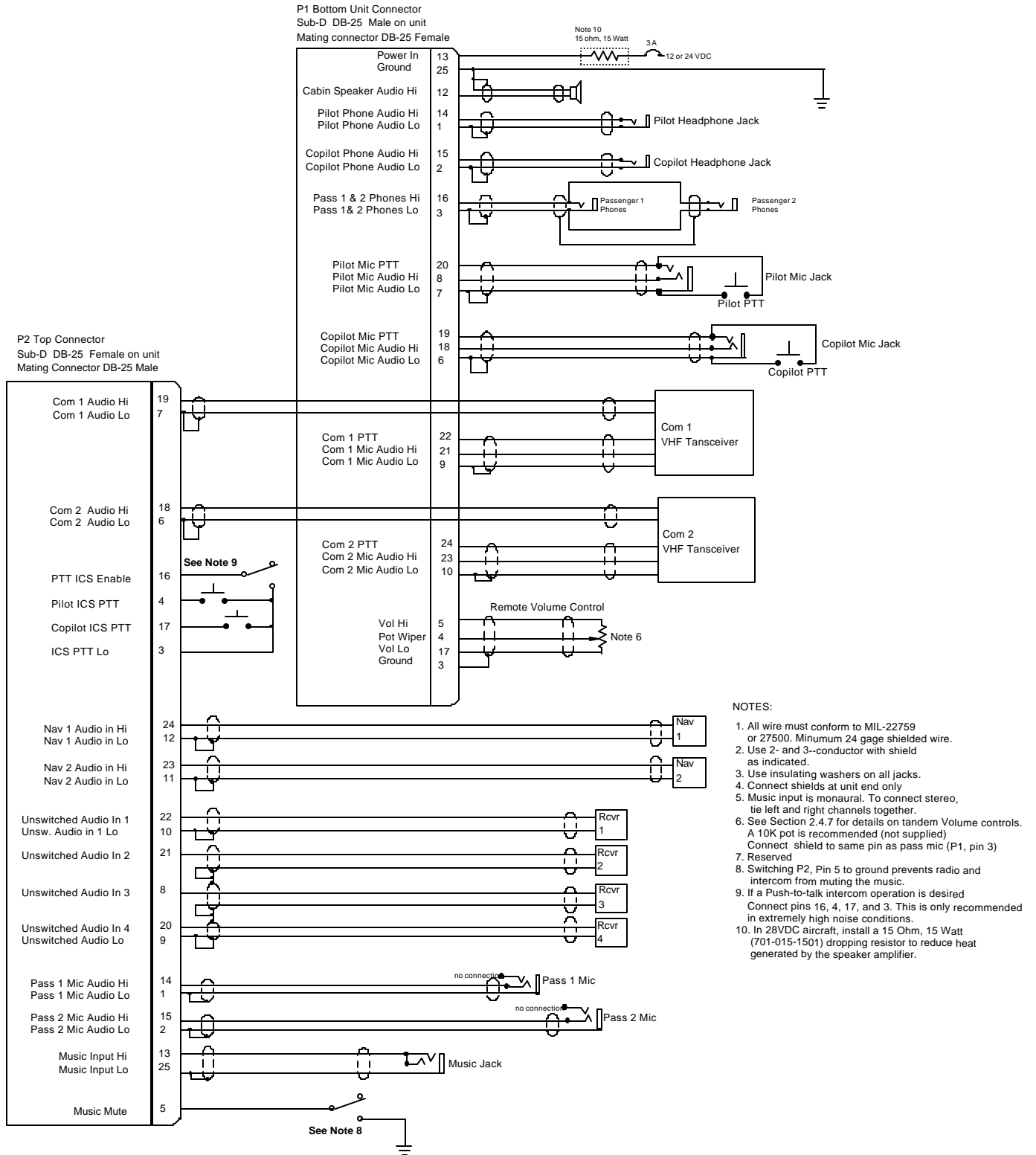


**Figure 6-3 Connector Layout**



**Figure 6-4 Installation Diagram**

## Appendix C Unit Connector Wiring



## Appendix D -Instructions for FAA Form 337 and Continuing Airworthiness

### Example for FAA Form 337

One method of airworthiness approval is through an FAA Form 337, *Major Repair and Alteration (Airframe, Powerplant, Propeller, or Appliance)* In the case of the PMA4000 TSOaudio panel you may use the following text as a guide.

Installed FAA-TSO Approved 4-place intercom/audio selector panel, PS Engineering PMA4000, part number 1194X at station    Installed per AC43.13-2, Chapter 2, paragraph 23 (Instrument Panel Mounting). Installed per PS Engineering *Installation Operators Manual* P/N 200-041-          , revision (X), dated       ,       .

Interface to existing aircraft radios in accordance with installation manual and in compliance with practices listed in *AC43.13-2*, Chapter 2. All wires are Mil-Spec 22759 or 27500. Connection to the aircraft dimmer bus is accomplished per the installation manual and   . Power is supplied to the unit through a 1A circuit breaker (type and part number), and total electrical load does not exceed       % of the electrical system capacity with the PMA4000 added.

Aircraft equipment list, weight and balance amended. Compass compensation checked. A copy of the operation instructions, contained in PS Engineering document 200-041-          , revision   ,        is placed in the aircraft records. All work accomplished listed on Work Order                           .

### Sample ICA Checklist for PS Engineering Audio Panels:

Section	Item	Information
1	Introduction	Installation of audio control panel and intercommunications system.
2	Description	Installation as described in manufacturer's installation manual referenced on FAA Form 337, including interface with other avionics audio as required.
3	Controls	See installation and operator's guide referenced on FAA Form 337.
4	Servicing	None Required
5	Maintenance Instructions	On Condition, no special instructions
6	Troubleshooting	In the event of a unit problem, place the unit into "off," "fail-safe" and/or "emergency" mode. This allows pilot communications using COM 1. Follow checkout instructions in the installation manual referenced on the FAA Form 337. For a specific unit fault, contact the manufacturer at (865) 988-9800 for special instructions.
7	Removal and replacement information	<u>Removal:</u> Remove knobs. Using a Philips screw drier, carefully remove the 2 screws through the face plate. The unit is then removed from the rear. Installation, Reverse installation procedure.
8	Diagrams	Not applicable
9	Special Inspection Requirements	Not Applicable
10	Protective Treatments	Not Applicable
11	Structural Data	Not Applicable
12	Special Tools	None

**PS Engineering**  
PMA4000 Series Audio Selector Panel and *IntelliVox*™ Intercom System  
Installation Manual

13	Not Applicable	Not Applicable
14	Recommended Overhaul Periods	None
15	Airworthiness Limitations	Not Applicable
16	Revision	To be determined by installer



## Appendix E RTCA DO160D (EUROCAE ED-14) Environmental Qualification Form

Nomenclature: Audio Selector Panel/Intercom

Part Number: 11942

FAA TSO Number: C50c

Manufacturer: PS Engineering Incorporated      9800 Martel Road      Lenoir City TN 37772

Conditions	Section	Conducted Tests
Temperature and Altitude	4.0	Equipment tested to CAT B1
Low Temperature	4.5.1	-55° C Storage, -20°C Low Operating (B1)
High Temperature	4.5.2	+85°C Storage, +70°C High Operating
In-flight Loss of Cooling	4.5.4	Not Applicable, no cooling required
Altitude	4.6.1	25,000' unpressurized
Decompression	4.6.2	Not Applicable
Overpressure	4.6.3	Not Applicable
Temperature variation	5.0	Equipment tested to Category C
Humidity	6.0	Equipment tested to Category A
Shock	7.0	Equipment tested Category B
Operational	7.2	
Crash Safety	7.3	
Vibration	8.0	Equipment tested to Category S R
Explosion	9.0	Category X, not tested
Waterproofness	10.0	Category X, not tested
Fluids Susceptibility	11.0	Category X, not tested
Sand and Dust	12.0	Category X, not tested
Fungus	13.0	Category X, not tested
Salt Spray	14.0	Category X, not tested
Magnetic Effect	15.0	Equipment tested to Category Z
Power input	16.0	Equipment tested to Category B
Voltage Spike	17.0	Equipment tested to Category B
Audio Frequency Susceptibility	18.0	Equipment tested to Category B
Induced Frequency Susceptibility	19.0	Equipment tested to Category B
Radio Frequency Susceptibility	20.0	Equipment tested to Category T
Radio Frequency Emission	21.0	Equipment tested to Category M
Lightning Induced Transient Susceptibility	22.0	Equipment tested to Category XXE2
Lightning Direct Effects	23.0	Category X not tested
Icing	24.0	Category X, not tested
Electrostatic Discharge Test	25.0	Category X, not tested