

ADS600-B™

Installation and User Manual



Business Address:

NavWorx Inc.
3906 Industrial St, Suite 100
Rowlett, TX 75088

Telephone:

(888)-NAVWORX (628-9679)

Facsimile:

888- 628-9679

Email: support@NavWorx.com

Website: www.NavWorx.com

Information in this document is subject to change without notice. NavWorx reserves the right to modify its products and documentation without notice and is under no obligation to notify anyone of such changes or improvements.

NavWorx is a registered trademark of NavWorx Incorporated. ADS600-B™ is a trademark of NavWorx Incorporated. These trademarks may not be used without the express written permission of NavWorx Incorporated.

No part of this document may be copied, reproduced, transmitted, disseminated, downloaded or stored on any storage medium without the express written permission of NavWorx. NavWorx grants permission to download a single copy of this document onto a hard drive or other electronic storage medium to be viewed for personal use as long as the downloaded or printed copy contains the complete text of this copyright notice. Unauthorized commercial distribution of any revision of this documentation is strictly prohibited.

Revision History

| Revision | Date | Comments |
|----------|------------|--|
| 01 | 04/20/2010 | Initial release |
| 02 | 05/11/2010 | Revised FCC statement |
| 03 | 08/29/2010 | Updated Wiring Diagrams. Added content to 3.4.1 GPS Antenna, 3.5.4 Cabling and Wiring, 3.5.5 Air Circulation and Cooling Sections, and 3.8.3 Mounting and Wiring Sections. |
| 04 | 09/12/2010 | Added ADS600-B to GRT Wiring Diagrams. Replaced text of Maintenance PC section with reference to Maintenance Port Tutorial document, 240-0007-00-02. |
| 05 | 09/18/2010 | Added Quick Start Guide and ADS600-B Maintenance Port Tutorial Sections. |
| 06 | 10/10/2010 | Changed download link for TeraTermPro |
| 07 | 10/17/2010 | Added GNS 430(W) (ARINC 429) Wiring Diagram. Added wiring diagrams to table of contents. |

End User License Agreement (EULA)

Terms. By installing or using the ADS600-B (“product”), you agree to be bound by the terms and conditions of the following license agreement. Please read this agreement carefully. NavWorx Incorporated (“NavWorx”) grants you a limited, non-exclusive license to use the product. Title, ownership rights, and intellectual property rights in and to the product remain with NavWorx.

Refund. If you do not agree to the terms of this EULA, NavWorx Inc. is unwilling to license the product to you. In such event, you may not use the licensed product, and you should promptly contact NavWorx for a refund. The product must not have been used or installed in order to obtain a full refund.

No Warranties. Except as expressly provided in the limited warranty section, the products’ hardware and its operating system software are provided to you “as is” without warranty of any kind, either expressed or implied, including, but not limited to, warranties of noninfringement, merchantability, and /or fitness for a particular purpose. The entire risk of the quality and performance of both the software and hardware is with the user.



Copyright. You acknowledge that the product is the property of NavWorx and is protected under United States of America copyright laws and international copyright treaties. You further acknowledge that the structure, organization, and source design of the hardware and software are valuable trade secrets of NavWorx. You agree not to open the product, break the EULA seal, nor decompile, disassemble, modify, reverse assemble, reverse engineer, or reduce to human readable form the hardware or software or any part thereof or create any derivative works based on the product.

No Liability for Consequential Damages. NavWorx Inc. and its suppliers shall not be held liable for any damages suffered or incurred by you (including, but not limited to, general, special, consequential or incidental damages for loss of business profits, business interruption, personal compensation and the like), arising from or in connection with the delivery, use, or performance of the product and its software.

Customer Remedies. NavWorx Inc. and its suppliers entire liability and your exclusive remedy shall be, at NavWorx’ option, either (1) return of the product purchase price, not to exceed list price, or (2) repair or replacement of the product which is returned to NavWorx with original proof of purchase.

Disclaimer

Symbology seen throughout this documentation highlight important information. The following table defines how to interpret these symbols:

| <i>Symbol</i> | <i>Description</i> |
|---|--------------------|
|  | Hazardous. |
|  | Warning. |
|  | Important. |



The ADS600-B is used as an aid to visual acquisition of traffic and weather and it is to be used only for pilot and crew situational awareness.



The ADS600-B does not relieve the flight crew of seeing and avoiding traffic, obstacles and weather. Installation of the ADS600-B does not relieve the pilot of consulting approved data sources prior to and during each flight.



The ADS600-B is not a *collision-avoidance-device*. Any deviation from ATC clearance, given cockpit information derived from the ADS600-B, must be approved by ATC.



The ADS600-B is a Universal Access Transceiver (UAT) that interfaces with an MFD or CDTI to display UAT, TIS-B and FIS-B products. NavWorx is not responsible for how a display device renders these products. Nor is NavWorx is not responsible for the failure of the display device to render these products.



The ADS600-B receives TIS-B and FIS-B products from ADS-R ground stations. NavWorx is not responsible for the content, or lack of content, in TIS-B and FIS-B product offerings by the FAA.



NavWorx is not responsible for the failure of ADS-R groundstations to broadcast TIS-B and FIS-B products.



NavWorx is not liable for damages as a result of use or misuse of the ADS600-B.



NavWorx has tested the product in accordance with FAA guidance material. However, issues may still be present. We'll make a best faith effort to resolve issues as they arise.



This product is licensed under an End User License Agreement (EULA). If you don't agree with the EULA, or this Disclaimer, you must return the equipment.

NavWorx Two Year Limited Warranty

Limited Warranty for FAA Certified Products. Certified NavWorx products are warranted to be free from defects in material and workmanship for two years from the date of original purchase. For the duration of the warranty period, at its option, NavWorx will repair or replace any product which fails during normal use. No charge will be made to the customer for parts and labor for product repair or replacement provided that the customer shall be responsible for all shipping cost. NavWorx, at its sole discretion, retains the exclusive right to either repair or replace the product unit with a new unit or with a newly reconditioned unit. Any replacement product will be warranted for the remainder of the original warranty period or ninety (90) days, whichever is longest.

Limited Warranty for Non-Certified Products. Non-certified NavWorx products are warranted to be free from defects in material and workmanship for two years from the date of first flight of the experimental aircraft in which the product is installed. Customer must provide proof of first flight when requesting warranty service. For the duration of the warranty period, at its option, NavWorx will repair or replace any product which fails during normal use. No charge will be made to the customer for parts and labor for product repair or replacement provided that the customer shall be responsible for all shipping cost. NavWorx, at its sole discretion, retains the exclusive right to either repair or replace the product unit with a new unit or with a newly reconditioned unit. Any replacement product will be warranted for the remainder of the original warranty period or ninety (90) days, whichever is longest.

Restrictions. This Limited Warranty does not apply if (a) the product has not been installed, operated, or maintained in accordance with instructions supplied by NavWorx, (c) has been altered, except by NavWorx or its authorized representative, or (c) has been subjected to abnormal physical or electrical stress, abnormal environmental conditions, misuse, negligence, or accident, (d) the factory applied original case seals or serial number label has been broken, altered or removed from the product.

Disclaimer of Warranty. EXCEPT AS SPECIFIED IN THIS WARRANTY SECTION, ALL EXPRESS OR IMPLIED CONDITIONS, REPRESENTATIONS, AND WARRANTIES INCLUDING, WITHOUT LIMITATION, ANY IMPLIED WARRANTY OR CONDITION OF MERCHANTABILITY, FITNESS FOR A PARTICULAR PURPOSE, STATUTORY OR OTHERWISE ARE HEREBY EXCLUDED TO THE EXTENT AN IMPLIED WARRANTY CANNOT BE EXCLUDED. SUCH WARRANTY IS LIMITED IN DURATION TO THE EXPRESS WARRANTY PERIOD. BECAUSE SOME STATES OR JURISDICTIONS DO NOT ALLOW LIMITATIONS ON HOW LONG AN IMPLIED WARRANTY LASTS, THE ABOVE LIMITATION MAY NOT APPLY. THIS WARRANTY GIVES THE CUSTOMER SPECIAL LEGAL RIGHTS AND THE CUSTOMER MAY HAVE OTHER LEGAL RIGHTS THAT MAY VARY FROM JURISDICTION TO JURISDICTION.

NAVWORX SHALL NOT BE LIABLE, IN ANY EVENT, FOR ANY INCIDENTAL, SPECIAL, INDIRECT OR CONSEQUENTIAL DAMAGES, WHETHER RESULTING FROM THE USE, MISUSE OR INABILITY TO USE THE PRODUCT OR FROM DEFECTS IN THE PRODUCT. BECAUSE SOME STATES OR JURISDICTIONS DO NOT ALLOW THE EXCLUSION OF INCIDENTAL OR CONSEQUENTIAL DAMAGES THE ABOVE LIMITATIONS MAY NOT APPLY TO YOU.

Warranty Service. Warranty repair service shall be provided directly by NavWorx. To obtain warranty service, an original copy of the sales receipt for the product from NavWorx or a retailer is required. The following steps describe how to return your unit for warranty service.

- ✓ **Step 1.** Call or email NavWorx and describe the problem that you are having and request a Return Material Authorization (RMA) tracking number. Also, provide the unit's serial number, your shipping address and daytime telephone number.

| | |
|-----------|--------------------------|
| Telephone | (888)-NAVWORX (628-9679) |
| Email | support@NavWorx.com |

- ✓ **Step 2.** Once you have received an RMA number, securely pack the unit and ship it, insured, to the following address:

NavWorx Incorporated
 RMA Number: *(insert your RMA number here)*
 3906 Industrial St, Suite 100
 Rowlett, TX 75088

ADS600-B Installation Quick Start Guide

The equipment installer must verify the items of this quick start guide prior to operating the ADS600-B unit in the National Airspace System (NAS). A log file recording the current configuration of the ADS600-B must be emailed to support@navworx.com for our support personnel to be able to answer your questions.

The following MUST be completed before powering up the ADS600-B:

- Connect (RG-400) the UAT antenna to the port labeled “UAT ANT”
- Connect (RG-400) the GPS antenna to the port labeled “GPS ANT”
- Connect ‘fused’ power to the ADS600-B unit via port 1 (DB37 connector)
- Ensure that the ADS600-B’s maintenance port (DB9 connector) is accessible
- Verify that a pressure altitude encoder source is connected to the ADS600-B (via the DB37 connector)
- Before your first flight you MUST verify the configuration of the ADS600-B unit.**
 - Position aircraft and the ADS600-B unit to have a ‘view’ of the sky and the GPS satellites
 - Load [TERATERM](#) onto your PC
 - Configure TeraTerm terminal emulator
 - Connect the (TeraTerm) COM port of your PC to the maintenance port (DB9 connector) of the ADS600-B unit
 - Enable TeraTerm logging
 - Type “READ ALL” on the TeraTerm input
 - Type “READ GPS ALL” on the TeraTerm input
 - Email log file (captured by TeraTerm) to support@navworx.com

Refer to the [ADS600-B Maintenance Port Tutorial](#) section for more detailed configuration instructions.

Table of Contents

| | |
|--|----|
| Revision History | 3 |
| List of Effective Pages | 4 |
| End User License Agreement (EULA) | 5 |
| Disclaimer | 6 |
| NavWorx Two Year Limited Warranty | 7 |
| ADS600-B Installation Quick Start Guide | 8 |
| Definitions and Acronyms | 13 |
| 1 Accessories and Packing List | 14 |
| 1.1 Unpacking Equipment | 14 |
| 1.2 Package Contents | 14 |
| 2 About this Manual | 15 |
| 2.1 FCC Grant of Equipment Authorization | 15 |
| 3 Equipment Description | 15 |
| 3.1 Overall Specifications | 16 |
| 3.2 Transmitter Specification | 18 |
| 3.3 System Interfaces | 18 |
| 3.3.1 Display | 19 |
| 3.3.2 Maintenance Port | 19 |
| 3.3.3 Annunciator Output | 19 |
| 3.4 Antenna Requirements | 19 |
| 3.4.1 GPS Antenna | 19 |
| 3.4.2 UAT Antenna | 19 |
| 3.5 Installation | 20 |
| 3.5.1 Materials Not Supplied | 20 |
| 3.5.2 Tools Required | 21 |
| 3.5.3 Equipment Mounting | 21 |
| 3.5.4 Cabling and Wiring | 22 |
| 3.5.5 Air Circulation and Cooling | 23 |
| 3.6 Electrical Connections | 23 |
| 3.6.1 Connectors | 23 |
| 3.6.2 Interface Connector Definition | 24 |
| 3.6.3 I/O Connector (P1) | 25 |
| 3.7 Functional Descriptions | 27 |
| 3.7.1 Power | 27 |

| | | |
|-------|--|----|
| 3.7.2 | Discrete Outputs..... | 27 |
| 3.7.3 | Discrete Inputs | 27 |
| 3.7.4 | PPS Time Mark Input | 28 |
| 3.7.5 | Serial Interfaces | 28 |
| 3.8 | Post Installation Check | 29 |
| 3.8.1 | Maintenance PC | 29 |
| 3.8.2 | Electrical Load Analysis..... | 29 |
| 3.8.3 | Mounting and Wiring Check | 30 |
| 3.8.4 | Functional Test..... | 31 |
| 3.8.5 | Weight and Balance | 31 |
| 4 | Limitations | 31 |
| 4.1 | Traffic Display..... | 31 |
| 5 | Troubleshooting | 31 |
| 6 | Maintenance | 31 |
| 6.1 | Altitude Source | 31 |
| 6.2 | Calibration | 31 |
| 6.3 | Tune-Up..... | 31 |
| 6.4 | Battery Replacement..... | 31 |
| 6.5 | Cleaning..... | 32 |
| | Product Registration..... | 33 |
| | ADS600-B Maintenance Port Tutorial | 34 |
| | ASSUMPTIONS | 34 |
| | POWERING UP THE ADS600-B..... | 35 |
| | ADS600-B COMMAND FORMAT | 36 |
| | CONFIGURING ICAO ADDRESS..... | 36 |
| | CONFIGURING ADS600-B FOR TRAFFIC/WEATHER DISPLAY DEVICES | 37 |
| | PRESSURE ALTITUDE INPUT | 37 |
| | DETERMINING GPS RECEPTION | 38 |
| | MONITORING TRAFFIC OUTPUT | 39 |
| | VIEW CURRENT ADS600-B CONFIGURATION & STATUS | 40 |
| | VERIFYING ADS600-B TO TRAFFIC DISPLAY INTERFACE | 40 |
| | UPGRADING ADS600-B SOFTWARE | 41 |
| | TERA TERM | 48 |
| | MAINTENANCE PORT TIPS | 51 |
| | MAINTENANCE PORT HELP COMMANDS | 52 |

| | |
|--|----|
| VERIFYING ADS600-B CONFIGURATION..... | 55 |
| Interconnect Diagram: ADS600 to GPSMAP® TIS-A | 56 |
| Interconnect Diagram: Bluetooth Display Port..... | 57 |
| Interconnect Diagram: Display Port | 58 |
| Interconnect Diagram: ADS600 Maintenance Port to Computer | 59 |
| Interconnect Diagram: Composite-TIS™ | 60 |
| Interconnect Diagram: ADS600 to AFS (TIS Traffic) | 61 |
| Interconnect Diagram: ADS600-B to GRT | 62 |
| Interconnect Diagram: ADS600-B to GRT HX/HS/WS (TIS Traffic) | 63 |
| Interconnect Diagram: GNS 480 ARINC 743A Position Source | 64 |
| Interconnect Diagram: ADS600-B to GNS 480 Traffic (ARINC 429) | 65 |
| Interconnect Diagram: ADS600-B to GNS 480 Traffic (RS-232 TIS) | 66 |
| Interconnect Diagram: ADS600-B to GNS 430 Traffic (ARINC 429) | 67 |
| Interconnect Diagram: ADS600 to Chelton..... | 68 |
| Interconnect Diagram: ADS600 to Chelton (Composite TIS™)..... | 69 |

List of Tables

| | |
|--|----|
| Table 1-1: Package Contents | 14 |
| Table 1-2: ADS600-B Installation Kit Contents (P/N 210-0004-00-00) | 14 |
| Table 3-1: Acceptable ADS600-B UAT Antennas..... | 20 |
| Table 3-2: Acceptable ADS600-B GPS Antennas..... | 21 |
| Table 3-3: Crimp Tools for High Density 22-24 AWG Socket Contact..... | 21 |
| Table 3-4: Connectors | 23 |
| Table 3-5: I/O Connector Pin-Out (P1) | 26 |
| Table 3-6: Recommended Circuit Breaker | 30 |
| Table 3-7: ADS600-B Weights | 31 |

List of Figures

| | |
|---|----|
| Figure 3-1: Top view of ADS600-B UAT Data Link Transceiver | 15 |
| Figure 3-2: ADS600-B UAT Data Link Transceiver System Diagram | 18 |
| Figure 3-3: ADS600-B Mounting Bracket Pattern | 22 |
| Figure 3-4: ADS600-B DB37, UAT and GPS Connectors | 24 |
| Figure 3-5: 37 Pin D-Sub Male Connector (P1) | 25 |

Definitions and Acronyms

| | |
|-----------------|---|
| ADC | Air Data Computer |
| ADS600-B | Automatic Dependent Surveillance universal access transceiver |
| ADS-B | Automatic Dependent Surveillance Broadcast |
| ADS-R | Automatic Dependent Surveillance Rebroadcast |
| AHRS | Attitude Heading Reference System |
| ATC | Air Traffic Control |
| CDTI | Cockpit Display of Traffic Information |
| FCC | Federal Communications Commission |
| FAA | Federal Aviation Administration |
| FIS-B | Flight Information Services Broadcast |
| MFD | Multifunction Display |
| GBT | Ground Based Transceiver (also known as ADS-R) |
| PC | Personal Computer |
| STC | Supplemental Type Certificate |
| TIS-A | Traffic Information Services provided by Mode S transponder |
| TIS-B | Traffic Information Services Broadcast |
| TSO | Technical Standard Order |
| UAT | Universal Access Transceiver |
| WAAS | Wide Area Augmentation System |

1 Accessories and Packing List

1.1 Unpacking Equipment

Carefully unpack the equipment from the shipping container. Inspect the ADS600-B unit and the package contents for evidence of shipping damage. Retain the shipping container and packaging material for reshipment if necessary.

1.2 Package Contents

The items included in the ADS600-B package are listed in Tables 1-1 and 1-2.

Table 1-1: Package Contents

| Part # | Quantity | Description |
|----------------|-----------------|---|
| 210-0004-00-00 | 1 | ADS600 Installation Kit (see Table 1-2 for details) |
| 200-0012-XX-XX | 1 | ADS600-B UAT Data Link Transceiver |

Table 1-2: ADS600-B Installation Kit Contents (P/N 210-0004-00-00)

| Part # | Quantity | Description |
|-------------------|-----------------|--|
| 201-205167-1 | 1 | Receptacle Female, DSUB 37-pin |
| 201-205161-1 | 1 | Receptacle Female, DSUB 9-pin |
| 201- DC-24660-33 | 1 | DSUB 37-pin back-shell |
| 201-5745407-1 | 1 | Connector DSUB Latch Slide 37 position |
| 201-M39029/63-368 | 20 | Crimp contact, DSUB, 20 to 24 AWG wire |

2 About this Manual

This manual describes the installation and checkout procedures for the ADS600-B UAT Data Link Transceiver.

The ADS600-B unit is intended to be installed in aircraft that do not require an STC for installation.

2.1 FCC Grant of Equipment Authorization

This equipment has been issued an FCC Grant of Equipment Authorization. The FCC ID is marked on the equipment nameplate.

3 Equipment Description

The ADS600-B UAT Data Link Transceiver contains a GPS/WAAS receiver and a Universal Access receiver and transmitter. This unit transmits a GPS position and aircraft information message once per second. Additionally, this unit receives messages from other UAT equipped aircraft and receives TIS-B/FIS-B messages from ADS-Rs. Data received by the ADS600-B is output to a display device.

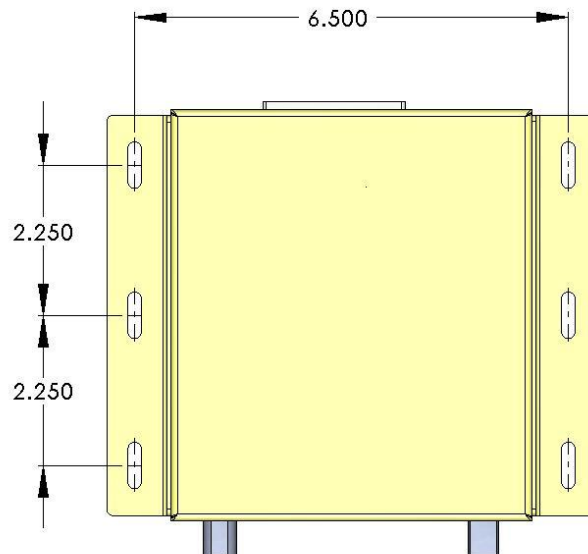

Figure 3-1: Top view of ADS600-B UAT Data Link Transceiver

3.1 Overall Specifications

This section includes the physical, electrical, performance and environmental specifications for the ADS600-B UAT Data Link Transceiver.

❖ Physical

| | |
|---------|---|
| Height: | 2.1 inches |
| Width: | 5.4 inches (w/o mounting bracket) 7.3 inches (w/ mounting bracket) |
| Depth: | 6.2 inches |
| Weight: | 1.5 lbs (w/o mounting bracket, excluding cables) 1.6 lbs (w/ mounting bracket, excluding cables) |

❖ Electrical

| | |
|------------------------------|---|
| Voltage: | 9-36VDC |
| Input Current (10W nominal): | Steady State: 0.7A @ 14VDC, 0.41A @ 24VDC Transmit Peak: 1.1A @ 14VDC, 0.59A @ 24VDC |

❖ UAT Performance

| | |
|-----------------------|---------------------------------|
| Regulatory: | DO-282B |
| Frequency: | 978MHz |
| Tolerance: | +/- 20ppm |
| Data Rate: | 1.04167 Mbps |
| Receiver Sensitivity: | Exceeds 90%MSR@-95dBm |
| Transmit Power: | 40W nominal at antenna |
| Equipment Class: | A1S (single bottom UAT antenna) |

❖ GPS/WAAS Receiver Performance

| | |
|---|-----------------------------------|
| Number of channels: | 20 |
| Frequency: | 1575.42MHz L1 |
| Sensitivity (Tracking Mode): | -159dBm (Tracking mode) |
| Sensitivity (Acquisition Mode): | -142dBm (Acquisition mode) |
| TTFH Hot (valid almanac, position, time and ephemeris): | 1 second |
| TTFH Warm (valid almanac, position and time): | < 35 seconds |
| TTFH Cold (valid almanac): | < 35 seconds |
| Reacquisition (<10seconds obstruction): | 0.1seconds |
| Position Update Interval: | 5Hz |
| Velocity: | 1,000 Kts maximum @ 60,000 ft MSL |
| Datum: | WGS-84 |

❖ Environmental

| | |
|------------------------------|----------------|
| Operating temperature: | -20°C to +55°C |
| Storage temperature: | -55°C to +85°C |
| Temperature variation: | 5°C per minute |
| Humidity: | 94% at 65°C |
| Maximum continuous altitude: | 40,000 feet |
| Decompression: | 40,000 feet |
| External Cooling: | Not required |

❖ Avionics Interfaces

| | |
|--------------------------|---|
| Annunciator Outputs: | Capable of sinking 500mA for turning on annunciator lamp |
| Altitude Encoder: | RS232 asynchronous serial, ARINC429 ADC/AHRS source |
| Maintenance Port: | RS232 asynchronous serial |
| External Position Input: | From ARINC743A source |
| Display: | RS232 asynchronous serial (Pass-through or Traffic interfaces) RS422 asynchronous serial (Pass-through or Traffic interfaces) ARINC735 Traffic interface TIS-A Traffic interface |

3.2 Transmitter Specification

The ADS600-B is a non-TSO device that complies with RTCA DO-282B.

3.3 System Interfaces

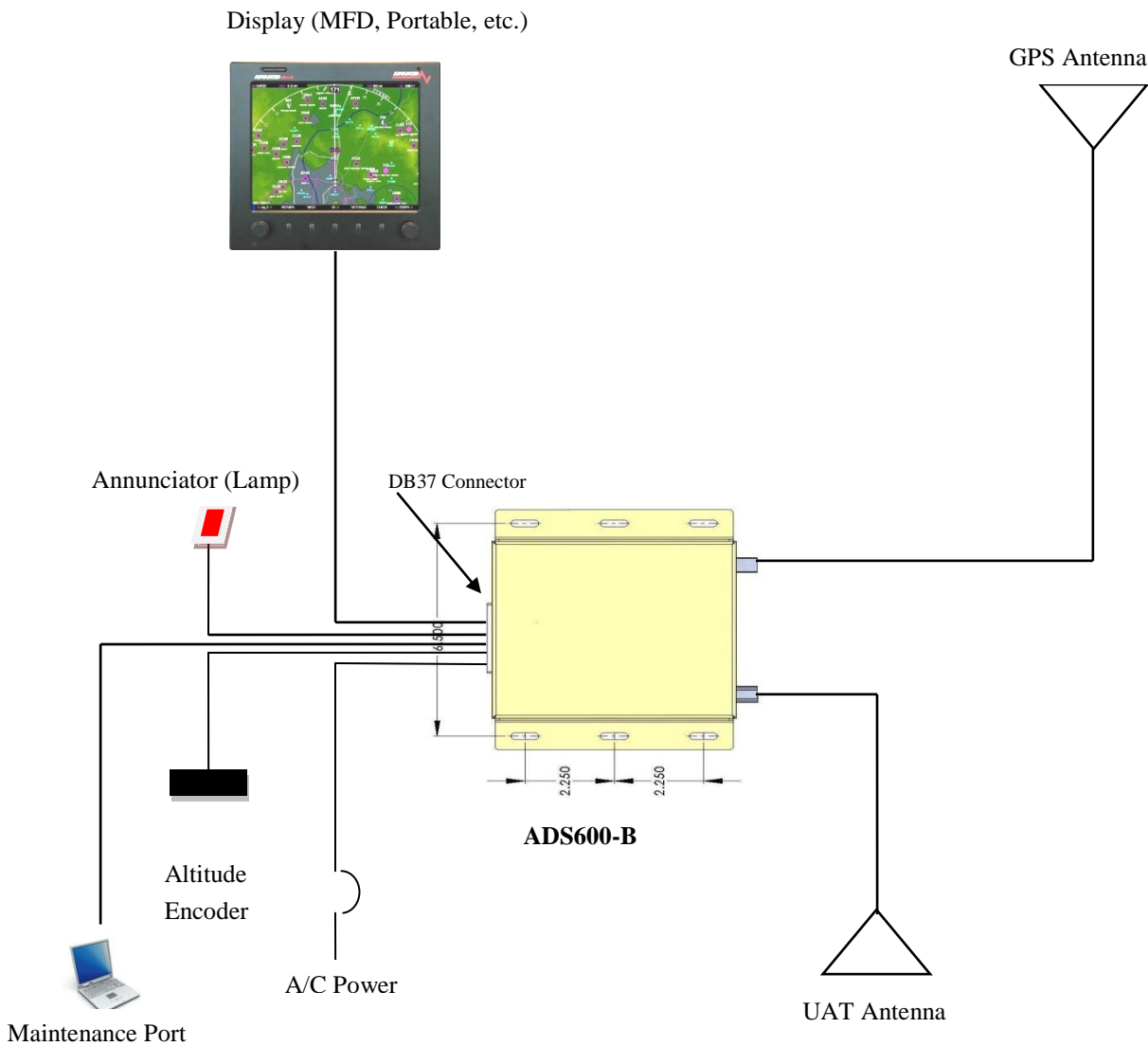

Figure 3-2: ADS600-B UAT Data Link Transceiver System Diagram

3.3.1 Display

The ADS600-B outputs traffic and weather information to compatible display. The ability to display traffic and/or weather depends on the display device.

3.3.2 Maintenance Port

The ADS600-B provides an RS232 communication port that is used to configure and monitor the status of the ADS600-B system via a computer. The maintenance port is required to be installed and connected.

3.3.3 Annunciator Output

The ADS600-B can drive an external annunciator lamp.

3.4 Antenna Requirements

3.4.1 GPS Antenna

The ADS600-B requires one GPS antenna. GPS antenna performance is critical to the operation of the ADS600-B GPS/WAAS receiver. Table 3-2 contains a list of GPS antennas that are recommended for use with the ADS600-B. Other GPS antennas may meet the installation requirements of the ADS600-B. Contact the factory to ensure antenna compatibility prior to installing your ADS600-B.

3.4.2 UAT Antenna

The ADS600-B requires one UAT antenna meeting the following specification: standard 50Ω vertically polarized antenna with a VSWR < 1.7:1 at 978MHz. Table 3-1 contains a list of UAT antennas that are recommended for use with the ADS600-B.



Some types (1030 and 1090MHz) of transponder antennas use very thin radiator elements. These types of antennas should be closely evaluated to determine their suitability as UAT data link antennas.



Operating the ADS600-B without RF terminations on the UAT Antenna port can result in equipment damage. Operate the ADS600-B with the UAT antenna port terminated with a VSWR ratio of 3.0:1 or less.

3.5 Installation

This section describes the installation of the ADS600-B including mounting, wiring and connections.

Read this entire section before proceeding with the installation of the ADS600-B.

Follow avionics installation practices per FAA Advisory Circular (AC) 43.13-1B, 43-13-2A, or FAA approved revisions to these documents.

Perform an electrical load analysis in accordance with AC 43.13-1B, Chapter 11, on the aircraft prior to installation to ensure that the aircraft's electrical system is capable of carrying the ADS600-B load. Section 3.1 describes the power consumption of the ADS600-B.

3.5.1 Materials Not Supplied

The following items are required for the ADS600-B installation, but are not supplied:

- UAT Antenna (Table 3-1 provides a list of recommended UAT Antennas)
- GPS Antenna, if installing an external GPS input for ADS600-B (Table 3-2 provides a list of recommended GPS Antennas)
- Wire (MIL-W-22759/16 or equivalent)
- Shielded wire (MIL-C-27500 or equivalent)
- Circuit Breakers
- Ring Terminals (for grounding)

Table 3-1: Acceptable ADS600-B UAT Antennas

| Manufacturer | Part Num | Connector | Hole Template |
|--------------|-----------|-----------|---|
| RAMI | AV-74 | BNC | http://www.rami.com/files/2/AV-74-Footprint.pdf |
| RAMI | AV-741 | BNC | http://www.rami.com/files/2/AV-741-Footprint.pdf |
| Comant | CI-105 | BNC | |
| Comant | CI-105-11 | TNC | |
| Delta Pop | ADSB-UAT | BNC | http://www.deltapopaviation.com/Delta_Pop_Aviation/Mounting_Detail.html |

Table 3-2: Acceptable ADS600-B GPS Antennas

| Manufacturer | Part Num | Connector | Hole Template |
|---------------------|-----------------|------------------|---|
| RAMI | AV-GPS | BNC | http://www.rami.com/files/2/AV-GPS-Footprint.pdf |
| Comant | CI-2480-400 | GPS Uses TNC | |
| Comant | CI-420-200 | TNC | |
| Comant | CI-429-200 | TNC | |

3.5.2 Tools Required

The D-Sub connector supplied with the ADS600-B uses crimp contacts. Table 3-3 identifies the crimp tool required to ensure consistent and reliable crimp contact connections for the D-Sub connector.

Table 3-3: Crimp Tools for High Density 22-24 AWG Socket Contact

| Type | Hand Crimping Tool | Positioner | Insertion/Extraction Tool |
|--------------|---------------------------|-------------------|----------------------------------|
| Military P/N | M22520/2-01 | M22520/2-09 | M81969/1-04 |
| Positronic | 9507 | 9502-3 | M81969/1-04 |
| AMP | 601966-1 | 601966-6 | 91067-1 |
| Daniels | AFM8 | K42 | M81969/1-04 |
| Astro | 615717 | 615725 | M81969/1-04 |

3.5.3 Equipment Mounting

The ADS600-B may be mounted in either a portable or remote mount configuration.

3.5.3.1 ADS600-B Portable Mount

The ADS600-B may be mounted in a portable configuration. The unit may be placed on a glare shield or any hard surface and affixed in place using Velcro®. The unit may also be portably attached to the aircraft using a RAM® mounting system.

3.5.3.2 ADS600-B Remote Mount

This option is recommended for non-certified, experimental or light sport aircraft to remotely mount the ADS600-B to the aircraft. The ADS600-B may be ordered with optional mounting brackets. Figure 3-3 describes the ADS600-B mounting bracket bolt pattern.

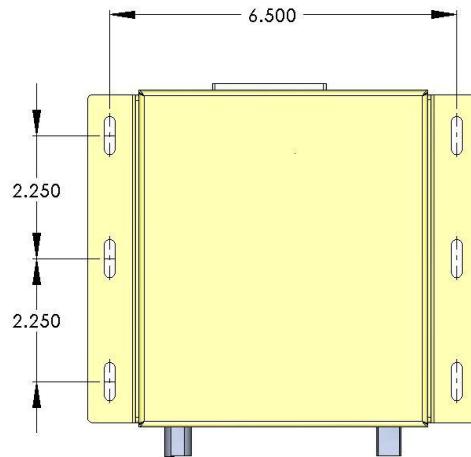

Figure 3-3: ADS600-B Mounting Bracket Pattern

3.5.3.3 Antenna Placement

3.5.3.3.1 GPS Antenna

The GPS Antenna placement guidelines can be found in AC 20-138A section 16. Refer to [http://rgl.faa.gov/REGULATORY_AND_GUIDANCE_LIBRARY/REGADVISORYCIRCULAR.NSF/0/8a2ae2491c85226f86256e35004c638b/\\$FILE/AC20-138A.pdf](http://rgl.faa.gov/REGULATORY_AND_GUIDANCE_LIBRARY/REGADVISORYCIRCULAR.NSF/0/8a2ae2491c85226f86256e35004c638b/$FILE/AC20-138A.pdf)

3.5.3.3.2 UAT Antenna

⚠ The UAT Antenna **MUST** be installed no less than 5 feet from any Transponder /TCAS/TAS or DME antenna. Failure to adhere to this critical installation note will result in failure of the ADS600-B and void your warranty.

3.5.4 Cabling and Wiring

The ADS600-B should be installed in accordance with Refer to AC 43.13-1B Chapter 11. Refer to [http://rgl.faa.gov/Regulatory_and_Guidance_Library/rgAdvisoryCircular.nsf/list/AC%2043.13-1B/\\$FILE/Chapter%2011.pdf](http://rgl.faa.gov/Regulatory_and_Guidance_Library/rgAdvisoryCircular.nsf/list/AC%2043.13-1B/$FILE/Chapter%2011.pdf)

- ✓ The cable harness should not be exposed to wire chafing
- ✓ The cable harness should not be located near the fuel lines.
- ✓ The cable harness should not be located near high electrical capacity lines.
- ✓ The cable harness should not be routed near high energy sources.
- ✓ The cable harness should not be located near the flight control cables.
- ✓ Isolate the cable harness from the engine. Install cable harness in a protected area of the aircraft.
- ✓ Grounding pigtails should not exceed more than 4 inches in length.

- ✓ RG-400 coaxial cable is required for UAT Antenna. UAT Antenna cable loss should not exceed 3 dB. The 11 foot cable supplied with the ADS600-B has 1.5 dB loss. Limit the RG400 cable length to 15 feet.
- ✓ RG-400 coaxial cable is recommended for the GPS Antenna. The GPS Antenna coaxial cable loss, including connectors, must be less than 10dB.
- ✓ Use 24 AWG or larger for all wiring except for power. See Wiring Diagrams section at the end of this document for recommended power and ground wiring.

3.5.5 Air Circulation and Cooling

The ADS600-B meets all DO-282B requirements without external cooling. However, as with all electronic equipment, lower operating temperatures will extend equipment life. It is not recommended to use outside forced air to cool the unit. Instead it is recommended that an electric forced air fan be installed to cool the equipment. If forced air cooling is installed, ensure that rainwater cannot enter or be sprayed on the ADS600-B.

3.6 Electrical Connections

3.6.1 Connectors

Table 3-4 describes the connectors supplied with the ADS600-B installation kit. The kit also contains crimp contacts for the D-Sub connector. Table 3-3 identifies the crimp tool required to ensure consistent and reliable crimp contact connections.

Table 3-4: Connectors

| Ref | Description | Connector Type | Crimp Contact |
|------------|--------------------|-------------------------|--------------------------|
| P1 | I/O | 37 Pin D-Sub Receptacle | 20-24 AWG socket contact |
| P2 | UAT Antenna | TNC connector. | N/A |
| P3 | GPS Antenna | TNC connector. | N/A |

3.6.2 Interface Connector Definition

The following figure shows the side view of the ADS600-B depicting the DSUB and TNC connectors.

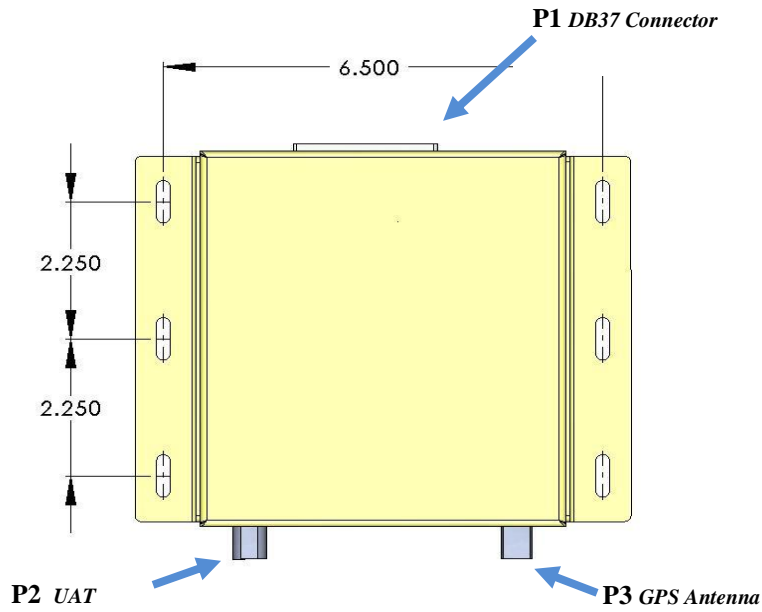
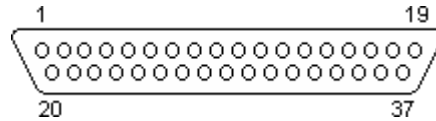

Figure 3-4: ADS600-B DB37, UAT and GPS Connectors

3.6.3 I/O Connector (P1)

A 37 pin D-Sub connector interfaces to external equipment and aircraft power. This connector can be found at the rear of the ADS600-B unit.



View looking at ADS600-B.

Figure 3-5: 37 Pin D-Sub Male Connector (P1)

The pin-out description for the I/O connector is defined in Table 3-5.

Table 3-5: I/O Connector Pin-Out (P1)

| Pin # | I/O | Name | Description |
|-------|-----|----------------------|--|
| 1 | -- | RESERVED | RESERVED |
| 2 | I | Time mark In - | ARINC 743A Time Mark In - |
| 3 | -- | Ground | RS232 Maintenance Port Ground |
| 4 | I | RS232 Maintenance RX | RS232 Maintenance Port Serial Data Input |
| 5 | O | RS232 TX | RS232 Display Serial Data Output |
| 6 | -- | Ground | RS232 Altitude Encoder and TIS Output Ground |
| 7 | I | Altitude Encoder RX | RS232 Altitude Encoder Input |
| 8 | O | 429 OUT 1B | ARINC 429 Output Channel 1B |
| 9 | I | 429 IN 1A | ARINC 429 Input Channel 1A |
| 10 | -- | RESERVED | RESERVED |
| 11 | I | External PPS TTL In | External PPS TTL In |
| 12 | O | RS422 TX - | RS422 Display Channel Data Output - |
| 13 | I | RS422 RX + | RS422 Display Channel Data Input + |
| 14 | O | UAT Fail Out | UAT Fail Output (active low) |
| 15 | I | TCAS RA Active In | TCAS Resolution Advisory Active Discrete In (active low) |
| 16 | -- | RESERVED | RESERVED |
| 17 | -- | RESERVED | RESERVED |
| 18 | -- | Power + | Main Aircraft Power Input (+9 to +36VDC) |
| 19 | -- | Power + | Main Aircraft Power Input (+9 to +36VDC) |
| 20 | -- | RESERVED | RESERVED |
| 21 | I | Time mark In + | ARINC 743A Time Mark In + |
| 22 | O | RS232 Maintenance TX | RS232 Maintenance Port Serial Data Output |
| 23 | -- | Ground | RS232 Display Ground |
| 24 | I | RS232 RX | RS232 Display Serial Data Input |
| 25 | O | TIS TX | TIS Serial Data Output |
| 26 | -- | RESERVED | RESERVED |
| 27 | O | 429 OUT 1A | ARINC 429 Output Channel 1A |
| 28 | I | 429 IN 1B | ARINC 429 Input Channel 1B |
| 29 | -- | RESERVED | RESERVED |
| 30 | O | RS422 TX + | RS422 display channel data output + |
| 31 | I | RS422 RX - | RS422 display channel data input - |
| 32 | -- | RESERVED | RESERVED |
| 33 | I | TCAS Operational In | TCAS Operational Discrete Input (active low) |
| 34 | I | Air/Ground In | Air / Ground Discrete Input (active low) |
| 35 | O | Suppression Output | Suppression Output (active high) |
| 36 | I | Power Ground | Main Aircraft Power Ground |
| 37 | I | Power Ground | Main Aircraft Power Ground |

3.7 Functional Descriptions

3.7.1 Power

Aircraft power is provided to the ADS600-B on the P1 I/O connector. The ADS600-B accepts input power from +9 to +36 VDC.

| | |
|-------|--------------|
| P1-18 | Power + |
| P1-19 | Power + |
| P1-36 | Power Ground |
| P1-37 | Power Ground |

3.7.2 Discrete Outputs

The ADS600-B provides discrete outputs to provide status and drive annunciator lamps or other equipment. All discrete outputs are active low (i.e. grounded when active) and are of open collector design, capable of sinking up to 500 mA.

3.7.2.1 UAT Fail Indicator

The UAT Fail Out (P1-14) is used to indicate the status of the ADS600-B receiver. UAT Fail Out will be grounded when the ADS600-B has detected a system failure. Otherwise, this output will be open.

3.7.2.2 Suppression Output

The Suppression Output (P1-35) is intended to suppress other L-band equipment (such as a transponder) when the UAT transmits. It will provide a high signal ($V_{in} - 1.0V$) whenever the UAT is transmitting and ground otherwise.

3.7.3 Discrete Inputs

The ADS600-B accepts discrete inputs to provide additional status information from the aircraft systems or equipment. All inputs are active low (i.e. grounded when active) and each input presents a load of greater than 100 k Ω .

3.7.3.1 Air/Ground Discrete Input

The Air/Ground In (P1-34) is reserved for future use. It provides air/ground status input to the ADS600-B. The function of this input is configurable via the Maintenance PC (refer to section 3.8.1). The Air/Ground Input must be configured for one of the following options:

- A grounded Air/Ground In indicates that the aircraft is on the ground. Otherwise, an open indicates that the aircraft is in the air.
- An open Air/Ground In indicates that the aircraft is on the ground. Otherwise, a grounded Air/Ground In indicates that the aircraft is in the air.

- An air/ground switch is not installed. The air/ground state is set automatically based on the GPS ground speed. The air/ground speed threshold is configurable.

3.7.4 PPS Time Mark Input

When used with an external ARINC 743A position source, the time mark signals from the navigation sensor are connected to the ADS600-B time mark input pins (P1-2 and P1-21).

3.7.5 Serial Interfaces

The ADS600-B provides two bi-directional RS-232 serial interfaces, one receive only RS232 interface, one transmit only RS232 interface, one bi-directional RS-422 interface and one ARINC 429 input/output. These serial interfaces can be connected to:

- Display(s)
- Maintenance PC
- Altitude Encoder

The serial port pin-outs are:

| | |
|-------|--|
| P1-13 | RS422 Display Serial Data Input + |
| P1-31 | RS422 Display Serial Data Input - |
| P1-12 | RS422 Display Serial Data Output - |
| P1-30 | RS422 Display Serial Data Output + |
| P1-9 | ARINC 429 Input Channel 1A |
| P1-27 | ARINC 429 Output Channel 1A |
| P1-28 | ARINC 429 Input Channel 1B |
| P1-8 | ARINC 429 Output Channel 1B |
| P1-7 | RS232 Altitude Encoder Serial Data Input |
| P1-25 | RS232 TIS Serial Data Output |
| P1-6 | RS232 Altitude Encoder and TIS Output Ground |
| P1-24 | RS232 Display Serial Data Input |
| P1-5 | RS232 Display Serial Data Output |
| P1-23 | RS232 Display Ground |
| P1-4 | RS232 Maintenance Port Serial Data Input |
| P1-22 | RS232 Maintenance Port Serial Data Output |
| P1-3 | RS232 Maintenance PC Ground |

3.7.5.1 RS232 Altitude Encoder Input

An altitude encoder input may be provided through a RS232 serial data input (P1-7 and P1-6) to the ADS600-B. The maintenance PC commands (see section 3.8.1) describe how to enable the serial port for the Altitude Encoder Input. The baud rate for this port is also configurable via a maintenance command.

3.7.5.2 RS232 TIS Output (Garmin portables GPSMAP® x96)

The ADS600-B may be configured to output TIS data via a RS232 serial data output (P1-6 and P1-25) to a portable GPSMAP® display device. The maintenance PC commands (see section 3.8.1) describe how to enable the serial data port for the TIS Output. The baud rate for this port is also configurable via a maintenance command.

3.7.5.3 RS422 In/Out Display

The ADS600-B may be configured to output to a display device using the RS422 serial interface (P1-12, P1-13, P1-30, and P1-31). The type of display device is configurable. The maintenance PC commands (see section 3.8.1) allow the installer to select a display device, as well as, a baud rate for the RS422 serial interface.

3.7.5.4 RS232 In/Out Display

The ADS600-B may be configured to output to a display device using the RS232 serial interface (P1-5, P1-23, and P1-24). The type of display device is configurable. The maintenance PC commands (see section 3.8.1) allow the installer to select a display device, as well as, a baud rate for the RS232 serial interface.

3.7.5.5 RS232 Maintenance PC

The ADS600-B communicates with the maintenance PC using a RS232 serial interface (P1-3, P1-4, and P1-22). This interface is used to view system status and to set the configuration of the ADS600-B. The maintenance PC serial channel is fixed at 115,200 baud, 8 data, no parity, 1 stop bit.

3.7.5.6 ARINC429

The ADS600-B provides one ARINC 429 input and output (P1-8, P1-9, P1-27, and P1-28) interface.

3.8 Post Installation Check

3.8.1 Maintenance PC

Refer to the [ADS600-B Maintenance Port Tutorial](#) section for a description of how to configure the ADS600-B unit via the Maintenance Personal Computer (PC).

3.8.2 Electrical Load Analysis

The ADS600-B is powered via a separate circuit breaker. For aircraft with multiple power buses, this circuit breaker is sourced from the non-essential bus. Circuits should be protected in accordance with guidelines in AC 43.13-1B, Chapter 11.

An electrical load analysis should be completed on each aircraft prior to installation in accordance with AC 43.13-1B, Chapter 11.

Table 3-6: Recommended Circuit Breaker

| ADS600-B/ADS600-B-B | 14 VDC | 28 VDC |
|----------------------------|---------------|---------------|
| Circuit Breaker | 3 AMP | 2 AMP |

The circuit breaker placard should be labeled “UAT.”

3.8.3 Mounting and Wiring Check

Verify that the ADS600-B is secured to the aircraft as described in section 3.5.3. Verify that both the UAT and GPS antennas are securely cabled to the appropriate connectors as depicted in Section 3.6.2. Verify that the display port, maintenance port and power/ground are securely cabled to the DB37 connector of the ADS600-B. Ensure that the slide lock of the DB37 is in the locked position. If any ADS600-B cabling is routed near the aircraft controls, verify free movement of the aircraft controls.

3.8.4 Functional Test

3.8.5 Weight and Balance

An aircraft weight and balance is required after installation of the ADS600-B. Follow the guidelines in AC 43.13-1B, Chapter 10, Section 2. Update the aircraft equipment list indicating the items relocated, added or removed. Table 3-8 identifies the weight of the ADS600-B equipment.

Table 3-7: ADS600-B Weights

| Item | Weight |
|---------------------------------|---------|
| ADS600-B Only | 1.5 lbs |
| ADS600-B with Mounting brackets | 1.6 lbs |

4 Limitations

4.1 Traffic Display

5 Troubleshooting

6 Maintenance

6.1 Altitude Source

The altitude source provide to the ADS600-B must be tested and inspected every 24 months as referenced in FAR 91.411

6.2 Calibration

There are no user-serviceable adjustments. There are no periodic maintenance functions to be performed on the ADS600-B product.

6.3 Tune-Up

The ADS600-B is tuned at the factory. No tune-up procedure or servicing is required by the user.

6.4 Battery Replacement

The internal GPS/WAAS receiver utilizes a lithium cell battery to store the GPS Almanac when the unit is not in operation. The lithium battery has an approximate service life of 7 years. The unit should be sent back to the factory for battery replacement every 7 years.

If the battery is not replaced per this interval, and becomes discharged, the ADS600-B will still remain fully functional and accurate; however the GPS acquisition time (during initial turn-on) will be increased.

6.5 Cleaning

The ADS600-B does not require regular cleaning.

Product Registration

Record the serial number of your unit here: _____

Please help us better support you by connecting to the NavWorx website (www.navworx.com) and completing the online product registration. Select the Product Registration link on the home page. You'll need to provide your product serial number when registering your unit.

ADS600-B Maintenance Port Tutorial

ASSUMPTIONS

This tutorial assumes that the ADS600-B is connected to a Personal Computer (PC) which is running a terminal emulator such as TeraTerm . The TeraTerm terminal emulator can be downloaded from: <http://en.sourceforge.jp/projects/ttssh2/releases/>

The baud rate of the terminal emulator must match that of the ADS600 maintenance port. The terminal emulator is configured for: baud rate 115200 bps, 8 bits, 1 stop bit, no parity and no flow control. Refer to the **Error! Reference source not found.** section for a diagram of the ADS600 maintenance port to PC serial port connection. Refer to the TERATERM section for a description on how configure the terminal emulator.

The aircraft should be located outside so as to allow the ADS600-B to receive the best GPS reception.

Unless otherwise noted, the commands described in this manual apply to both the ADS600 Receiver and ADS600-B Transceiver units.

POWERING UP THE ADS600-B

When the ADS600-B powers up, it will send a power up message to the terminal emulator display. See Figure A below for an example of the power up message.

```

COM1:115200baud - Tera Term VT
File Edit Setup Control Window Help
Serial Number: 713
SW Version Number: 2.2.0

Protocols:
  SKY UISION
    Compatible Displays: SKY UISION EXTREME
    Services: FIS-B, TIS-B, TIS-A
    Port Assigned: RS232 (115200 BPS)
  TIS
    Compatible Displays: Advanced Flight Systems, Gra
    nd Rapids, Garmin GPSMAP 396/495/496/695/696
    Services: TIS-B, TIS-A
    Uses TIS port

Max targets: 32
ICAO Address: 0x000000
A/C Category: Light ICAO < 15500LBS
A/C Callsign:
CSID Logic: enabled
GPS Antenna: Lat Axis left 0.00m, Long Axis nose 0.00m
Flight ID: 1200
Self Assigned Address: disabled
A/C Emergency Code: No Emergency
Target Containment Altitude FT: 4000
Target Containment Distance NM: 25.00
Ghost Containment Altitude feet: 1000
Ghost Containment Distance nautical miles: 1.00
Ghost Containment Track Degrees: 60
Ghost Containment Ground Speed knots: 30
Ghost changed 0 times
No ghost found 0 times
Target Coasting Time: 6 seconds
ARINC429 Installed: FALSE
Composite-TIS Enabled: false
Transmitter Enabled: true
Primary Source: GEOMETRIC: 00498 MSL
Secondary Source: UNKNOWN: ----- MSL
GPS Position Source: Internal
FIS: Total 4 Messages Displayed; From ANY Station
TX PWR: 40 Watts
  
```

Figure A: ADS600-B Power Up Message

ADS600-B COMMAND FORMAT

ADS600-B maintenance port commands fall into 4 categories:

- 1) **SET** commands that allow the user to configure the ADS600-B
- 2) **READ** commands that display the status or configuration of the ADS600-B,
- 3) **MAP** commands that map a display protocol to a display port, and
- 4) **ENABLE|DISABLE** commands that enable or disable ADS600-B features.

Some commands are repeatable, as opposed to one-time commands. One-time commands elicit a single response from the ADS600-B. Repeatable commands are those whose repetition rate can be selected by the user and will display information at the repetition rate provided until the user interacts to stop the display. An example of a repeatable command is **READ GPS 2**. This command displays the reception status of the GPS receiver every 2 seconds. An example of a one-time command is **READ GPS ALL**. This displays the reception status of the GPS receiver one time.

[MAINTENANCE PORT HELP COMMANDS](#) contains a list of the ADS600-B commands. Also, entering the **HELP** command will list all of the available commands. The following sections describe some of the more commonly used ADS600-B commands.

[MAINTENANCE PORT TIPS](#) contains tips on entering maintenance port commands.

CONFIGURING ICAO ADDRESS

It is required to set the ICAO address for your aircraft. Go to the www.faa.gov website and find your aircrafts Mode-S code. This number is in octal format. Use an appropriate calculator to convert this octal number to a hex number. Use the **SET ICAO 0x<hex_number>** command to set your ICAO address. Use either **READ ICAO** or **READ ALL** command to verify that your ICAO is correctly set.

CONFIGURING ADS600-B FOR TRAFFIC/WEATHER DISPLAY DEVICES

To configure the ADS600-B traffic and weather display port, the port type and speed, and the type of protocol to be mapped to the display port must be specified. For example, to configure the ADS600-B traffic and weather output for the SkyVision Extreme, the following commands would be entered:

```
SET PROTOCOL SKY
MAP SKY RS232
SET BAUD RS232 115200
```

Since the TIS-A protocol has a dedicated port on the ADS600-B it is possible to output traffic to the TIS-A port, as well as, the serial display port. For example, to configure the ADS600-B traffic and weather output for the SkyVision Extreme and a TIS-A display (such as the Garmin® GPSMAP 496), the following commands would be entered (note the baud rate is only applicable to the SkyVision display as the TISA is always 9600):

```
SET PROTOCOL SKY TISA
MAP SKY RS232
SET BAUD RS232 115200
```

The **READ ALL** command can be used to verify the correct display port configuration.

The ADS600-B supports several display protocols and display port types. [MAINTENANCE PORT HELP COMMANDS](#) lists the protocols specified by the **SET PROTOCOL type**, the baud rates for the **SET BAUD RS232|RS422 baud-rate** command, and the display-protocol to port-mapping options of the **MAP protocol port-type** command.

ENABLING COMPOSITE TIS (OPTIONAL)

If the ADS600-B is wired to accept TIS-A traffic sent from a Mode S transponder, then Composite TIS must be enabled. Enabling Composite TIS will allow the ADS600-B to forward both TIS-A traffic and UAT traffic to the configured traffic display devices. Enter the **ENABLE COMPTIS** command to enable Composite TIS. Enter **DISABLE COMPTIS** to disable the Composite TIS command.

PRESSURE ALTITUDE INPUT

Provide the ADS600-B with a pressure altitude input. This can be accomplished with either the dedicated serial input, or if the unit has the optional ARINC-429 interface, it will take Arinc label 203.

 If the ADS600-B is not configured to use a pressure altitude encoder input, it uses the geometric altitude (GPS altitude) for all altitude references. The geometric and pressure altitudes may differ by many hundreds of feet. This becomes critical when determining how close a traffic target is to your ownship. Today, all traffic targets report pressure altitude to ATC (via the aircrafts altitude encoder). If the ADS600-B is using the geometric altitude for its ownship altitude reference, the accuracy of the altitude distance measure of a traffic target to the ownship altitude may be inaccurate by many hundreds of feet.

To confirm that the pressure altitude encoder input is configured and indicates the correct pressure altitude, enter the **READ ALL** command and verify that the PRIMARY altitude indicates the pressure altitude source.

DETERMINING GPS RECEPTION

To determine if the ADS600-B is receiving signals from the GPS constellation the user may enter either a repeatable or one-time GPS command. The repeatable command format is **READ GPS *num_of_seconds***, where *num_of_seconds* can be specified from 1 to 30 seconds. For example if **READ GPS 5** is entered, the GPS constellation status will be displayed every 5 seconds. The one-time command format is **READ GPS ALL**. This command will display the GPS constellation status one time.

Figure B shows the display output of the **READ GPS 5** command. To determine whether you have good GPS satellite reception verify that the #SVs (Space Vehicle) is greater than or equal 7. When “DGPS Corrections” is displayed WAAS is enabled.

#SVs reporting less 7 may indicate that your GPS antenna and/or cable may need maintenance.

```

COM1:115200baud - Tera Term VT
File Edit Setup Control Window Help
UTC: 9/12/2010 : 20:12:36 - LAT:32.905842 LONG:-96.565300 ALT:511 HDG:22 sHDG:2206 HU:2 UU:0 m100uv:-8
NU:0x0000 >=5SU
NT:0x0284 4 or more SU KF no alt hold DGPS Corrections nav overdetermined
#SU:5 SUList:0x20100C8 HPE:1.4m, UPE:1.6m, HUE:0.0m/s (S4,AZ190,EL30,CN41) (S8,AZ166,EL43,CN44) (S17,AZ321,EL69,
CN20) (S7,AZ156,EL10,CN35) (S26,AZ249,EL15,CN40) (S138,AZ198,EL50,CN42)
UTC: 9/12/2010 : 20:12:41 - LAT:32.905834 LONG:-96.565300 ALT:508 HDG:25 sHDG:2484 HU:1 UU:0 m100uv:-10
NU:0x0000 >=5SU
NT:0x0284 4 or more SU KF no alt hold DGPS Corrections nav overdetermined
#SU:5 SUList:0x20100C8 HPE:1.4m, UPE:1.7m, HUE:0.0m/s (S4,AZ190,EL30,CN41) (S8,AZ166,EL43,CN44) (S17,AZ321,EL69,
CN20) (S7,AZ156,EL10,CN35) (S26,AZ249,EL15,CN40) (S138,AZ198,EL50,CN42)
UTC: 9/12/2010 : 20:12:46 - LAT:32.905842 LONG:-96.565292 ALT:508 HDG:21 sHDG:2123 HU:2 UU:0 m100uv:-6
NU:0x0000 >=5SU
NT:0x0284 4 or more SU KF no alt hold DGPS Corrections nav overdetermined
#SU:5 SUList:0x20100C8 HPE:1.4m, UPE:1.7m, HUE:0.0m/s (S4,AZ190,EL30,CN41) (S8,AZ166,EL43,CN44) (S17,AZ321,EL69,
CN20) (S7,AZ156,EL10,CN35) (S26,AZ249,EL15,CN40) (S138,AZ198,EL50,CN41)
UTC: 9/12/2010 : 20:12:51 - LAT:32.905834 LONG:-96.565308 ALT:515 HDG:23 sHDG:2419 HU:1 UU:0 m100uv:-9
NU:0x0000 >=5SU
NT:0x0284 4 or more SU KF no alt hold DGPS Corrections nav overdetermined
#SU:6 SUList:0x20104C8 HPE:1.3m, UPE:1.6m, HUE:0.0m/s (S4,AZ190,EL30,CN41) (S8,AZ166,EL43,CN44) (S17,AZ322,EL69,
CN21) (S7,AZ156,EL10,CN35) (S11,AZ49,EL30,CN21) (S26,AZ249,EL15,CN40) (S138,AZ198,EL50,CN42)
UTC: 9/12/2010 : 20:12:56 - LAT:32.905815 LONG:-96.565323 ALT:524 HDG:36 sHDG:3724 HU:0 UU:0 m100uv:-1
NU:0x0000 >=5SU
NT:0x0284 4 or more SU KF no alt hold DGPS Corrections nav overdetermined
#SU:5 SUList:0x20004C8 HPE:1.3m, UPE:1.6m, HUE:0.0m/s (S4,AZ190,EL30,CN41) (S8,AZ166,EL43,CN44) (S7,AZ156,EL10,C
N35) (S11,AZ49,EL30,CN21) (S26,AZ249,EL15,CN40) (S138,AZ198,EL50,CN41)

```

Figure B: READ GPS 5 Command Output

VIEW CURRENT ADS600-B CONFIGURATION & STATUS

The **READ ALL** command displays the current status and configuration of the ADS600-B. Figure D shows the output of the **READ ALL** command.

```

COM1:115200baud - Tera Term VT
File Edit Setup Control Window Help
READ ALL
Serial Number: 713
SW Version Number: 2.2.0
Protocols:
  SKY UISION
    Compatible Displays: SKY UISION EXTREME
    Services: FIS-B, TIS-B, TIS-A
    Port Assigned: RS232 <115200 BPS>
  TIS
    Compatible Displays: Advanced Flight Systems, Grand Rapids, Garmin GPSMAP 396/495/496/695/696
    Services: TIS-B, TIS-A
    Uses TIS port
Max targets: 32
ICAO Address: 0x000000
A/C Category: Light ICAO < 15500LBS
A/C Callsign:
CSID Logic: enabled
GPS Antenna: Lat Axis left 0.00m, Long Axis nose 0.00m
Flight ID: 1200
Self Assigned Address: disabled
A/C Emergency Code: No Emergency
Target Containment Altitude FT: 4000
Target Containment Distance NM: 25.00
Target Coasting Time: 6 seconds
ARINC429 Installed: FALSE
Composite-TIS Enabled: false
Transmitter Enabled: true
Primary Source: UNKNOWN: ---- MSL
Secondary Source: UNKNOWN: ---- MSL
GPS Position Source: Internal
FIS: Total 4 Messages Displayed; From ANY Station
TX PWR: 40 Watts

```

Figure D: READ ALL Command Output

VERIFYING ADS600-B TO TRAFFIC DISPLAY INTERFACE

To verify that the ADS600-B is correctly connected to your traffic display device(s) enable the ADS600-B simulation mode. To do this, enter **ENABLE SIM** at the terminal emulator input. Your display device should display 1 traffic target. If your ownship's heading is north then the traffic targets should be displayed at 0°, 45° and 90°. Note, while in simulation mode the ADS600-B is still receiving UAT signals from other UAT equipped aircraft and the ADS-B ground stations so you may see more than 3 traffic targets on your traffic display device.

The simulation mode is disabled either by cycling power on the ADS600-B or entering the **DISABLE SIM** command. Remember to disable the simulation mode prior to flying.

UPGRADING ADS600-B SOFTWARE

Power up the ADS600-B, connect the maintenance port and run the terminal program (TeraTerm).

Verify that the ADS600-B powered up correctly by viewing the startup info on the terminal program. It should look something like this:

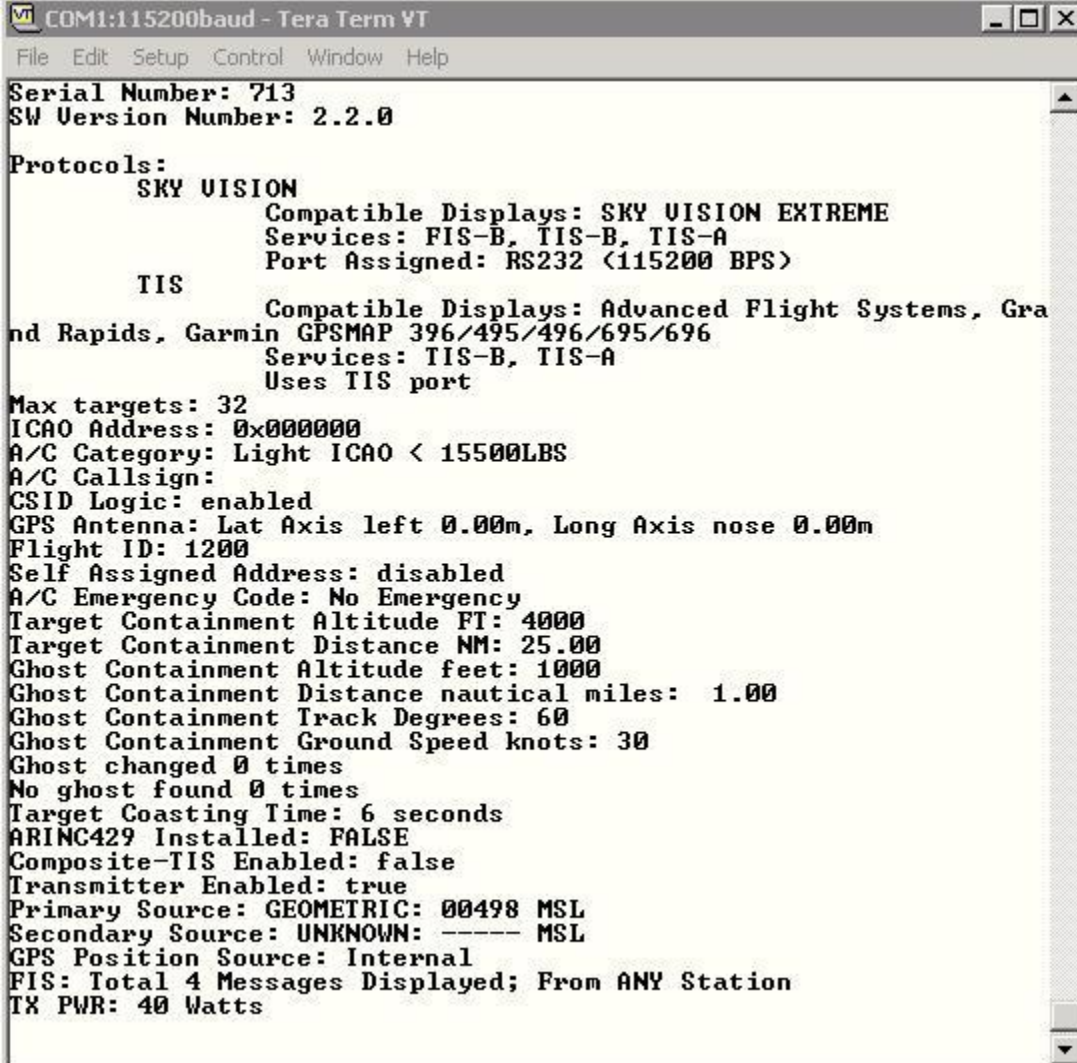

```

COM1:115200baud - Tera Term VT
File Edit Setup Control Window Help
Serial Number: 713
SW Version Number: 2.2.0

Protocols:
  SKY VISION
    Compatible Displays: SKY VISION EXTREME
    Services: FIS-B, TIS-B, TIS-A
    Port Assigned: RS232 <115200 BPS>
  TIS
    Compatible Displays: Advanced Flight Systems, Gra
nd Rapids, Garmin GPMAP 396/495/496/695/696
    Services: TIS-B, TIS-A
    Uses TIS port
Max targets: 32
ICAO Address: 0x000000
A/C Category: Light ICAO < 15500LBS
A/C Callsign:
CSID Logic: enabled
GPS Antenna: Lat Axis left 0.00m, Long Axis nose 0.00m
Flight ID: 1200
Self Assigned Address: disabled
A/C Emergency Code: No Emergency
Target Containment Altitude FT: 4000
Target Containment Distance NM: 25.00
Ghost Containment Altitude feet: 1000
Ghost Containment Distance nautical miles: 1.00
Ghost Containment Track Degrees: 60
Ghost Containment Ground Speed knots: 30
Ghost changed 0 times
No ghost found 0 times
Target Coasting Time: 6 seconds
ARINC429 Installed: FALSE
Composite-TIS Enabled: false
Transmitter Enabled: true
Primary Source: GEOMETRIC: 00498 MSL
Secondary Source: UNKNOWN: ----- MSL
GPS Position Source: Internal
FIS: Total 4 Messages Displayed; From ANY Station
TX PWR: 40 Watts
  
```

Save the ADS600-B release to your PC. The following example shows where the ADS600-B releases are saved:

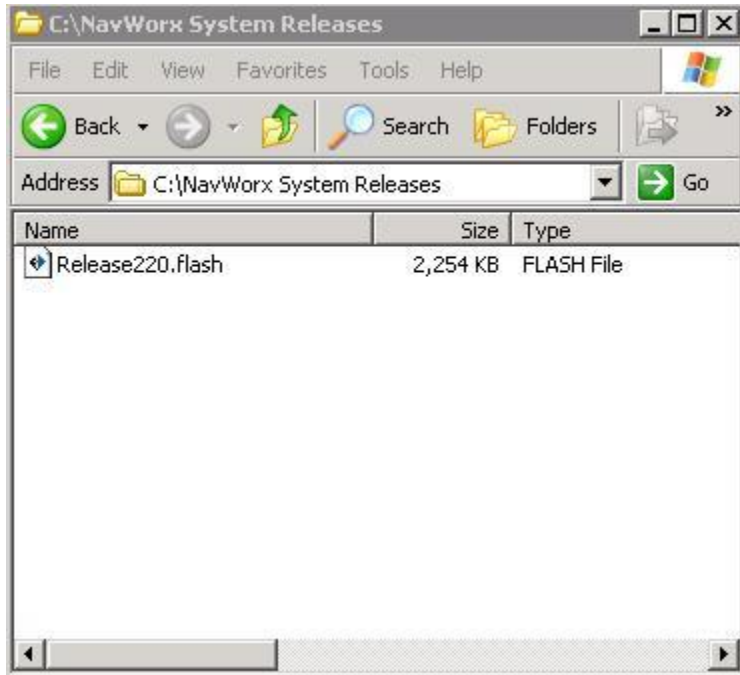

Figure E: ESTABLISH ADS600-B SOFTWARE RELEASE DIRECTORY ON PC

Now type in the “**SET LOADER**” command. The terminal should look something like this:

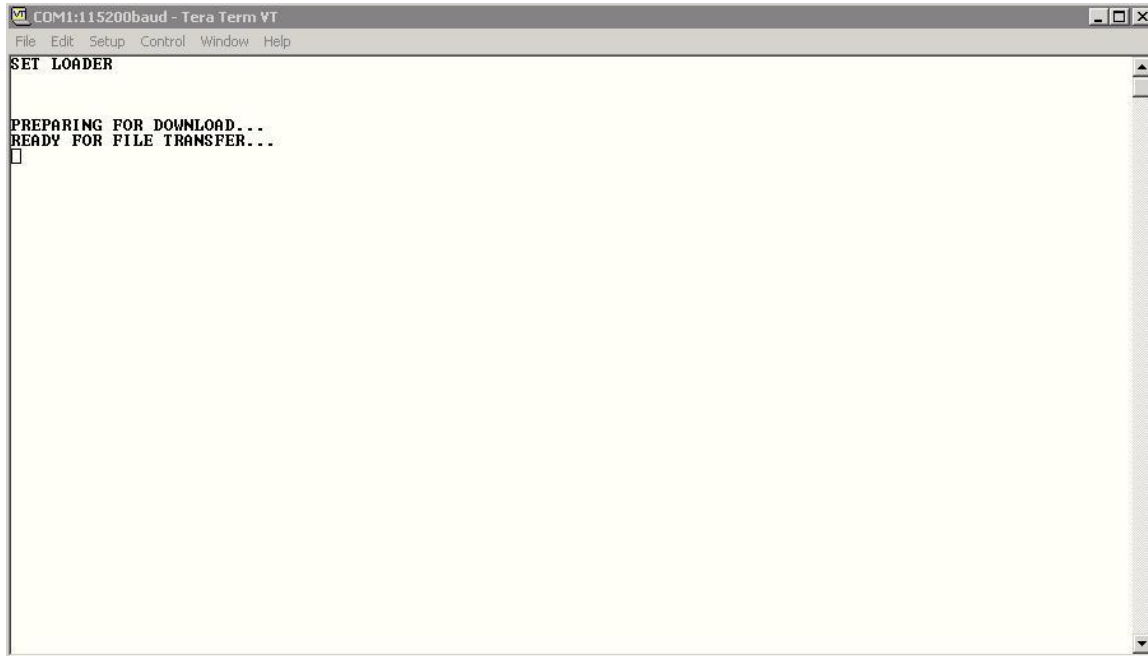

Figure F: SET LOADER COMMAND

After the “READY FOR FILE TRANSFER” message appears, send the attached “flash” file (file with the extension of .flash). Using the TeraTerm program, browse to the flash file that will be loaded. TeraTerm should look something like this:

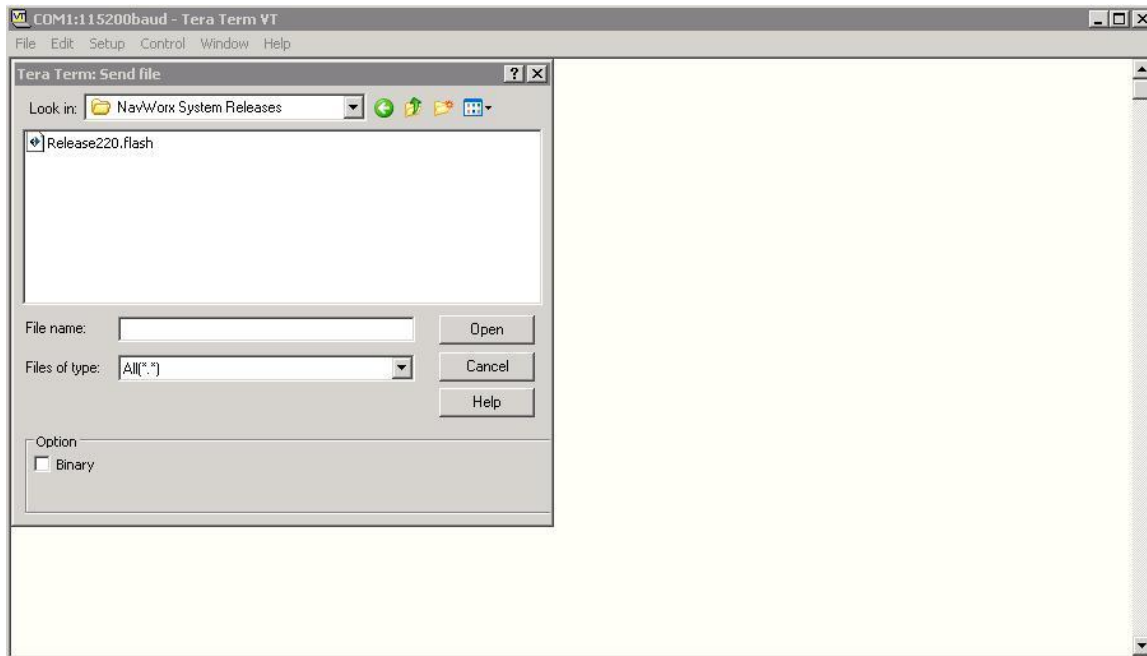

Figure G: TeraTerm SELECT FILE TO TRANSFER TO ADS600-B

From the terminal program, send this file to the ADS600-B just once. To send the file, select “Open”.

The file takes about 3 minutes to load. During this time, the terminal program will display an increasing number of "." characters:

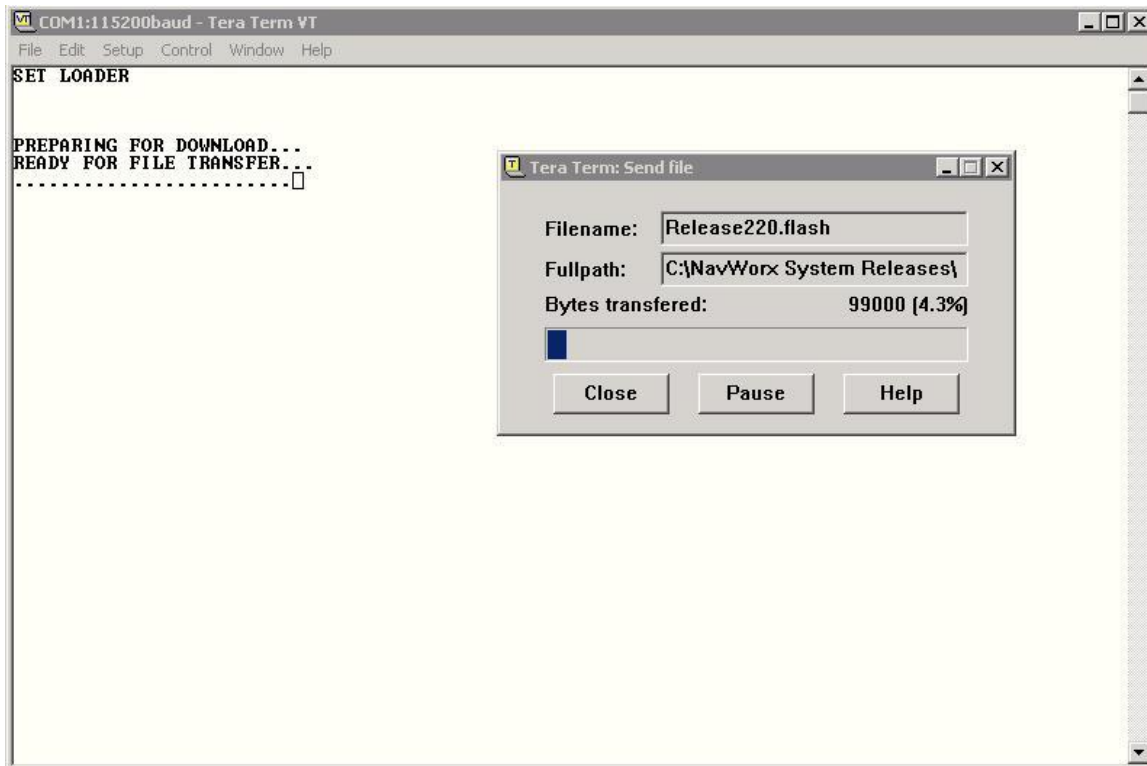

Figure H: ADS600-B FILE TRANSFER STATUS

The ADS600-B now instructs that the power should be cycled (turned off, then on). When powered up, the ADS600-B will show its startup screen, and you should verify that the new software release number is displayed (see Figure A). That's it! Your ADS600-B is now ready for flight!

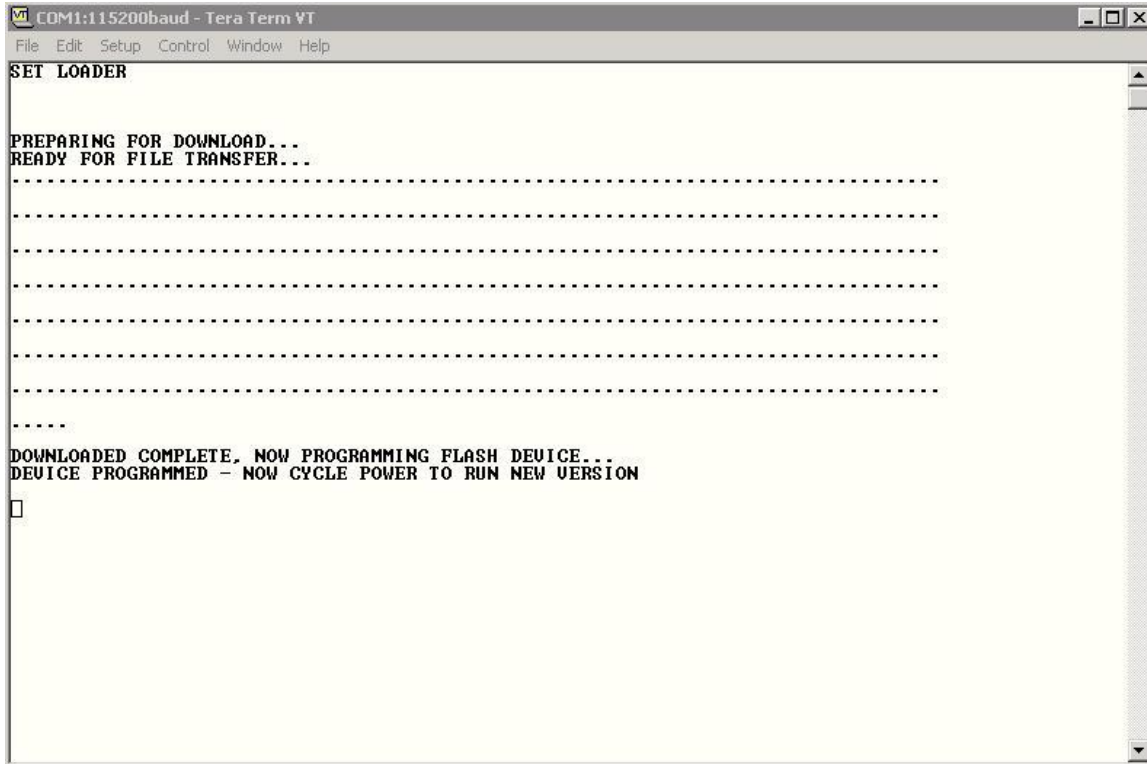

Figure J: POWER CYCLE ADS600-B

TERATERM

DOWNLOAD:

<http://ttssh2.sourceforge.jp>

ABOUT TeraTerm:

TeraTerm 4.6.7 is the latest version as of this document release.

After launching TeraTerm go to the Setup/Terminal page and set both the Transmit and Receive New Line to CR+TX. Also, set the Terminal ID to VT320. Verify that Local Echo is unselected.

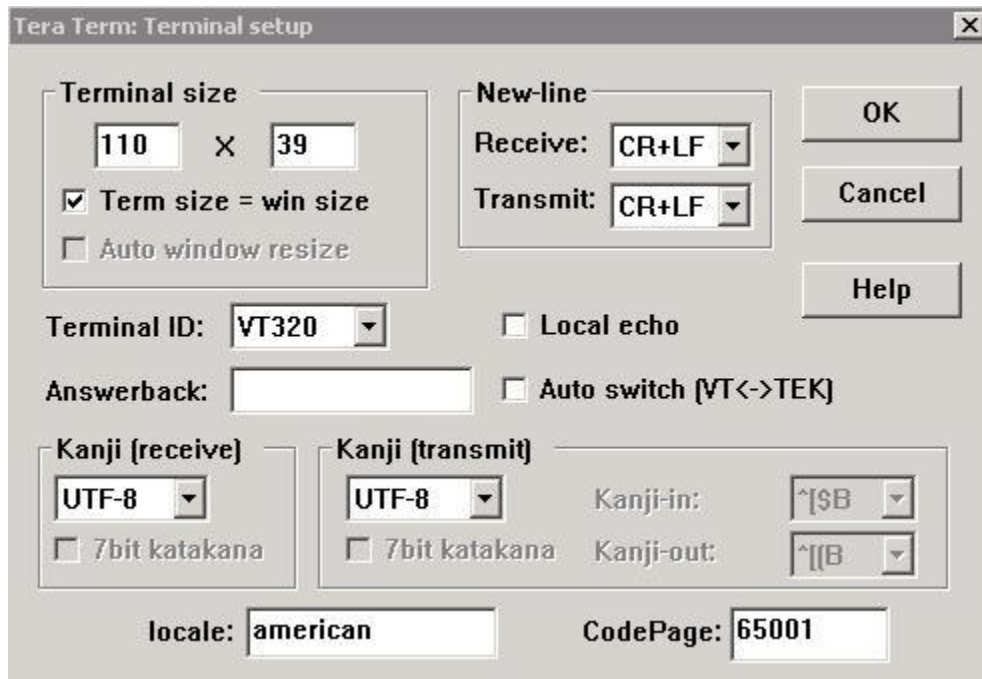

Figure K: TeraTerm TERMINAL SETUP

The baud rate of the terminal emulator must match that of the ADS600-B maintenance port so go to Setup/Serial Port and use the COM port of your choice configured for: baud rate 115200 bps, 8 bits, 1 stop bit, no parity and no flow control.

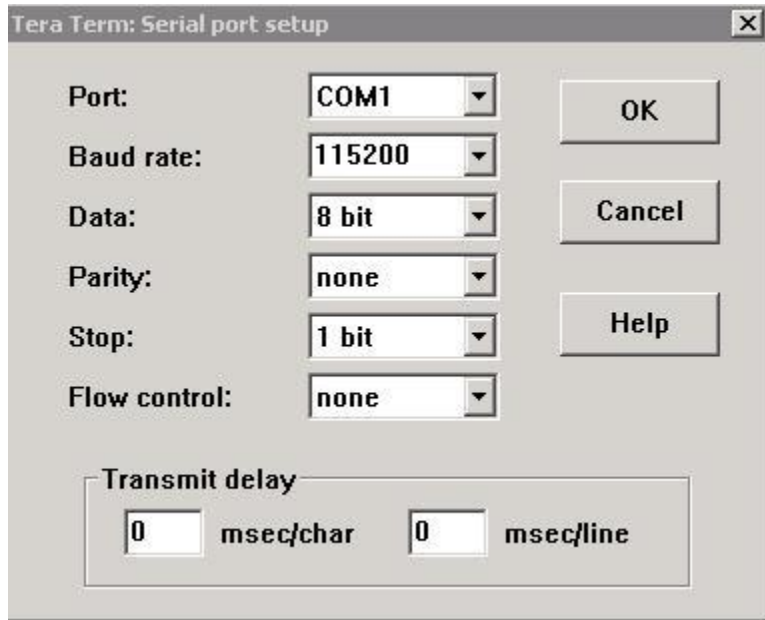

Figure L: TeraTerm PORT SETUP

These properties assume COM 1 port. If your computer is using another port, you should modify the "Port: COM1" selection above.

To log the output of the ADS600-B unit go to the TeraTerm Log page and select the file to save the output:

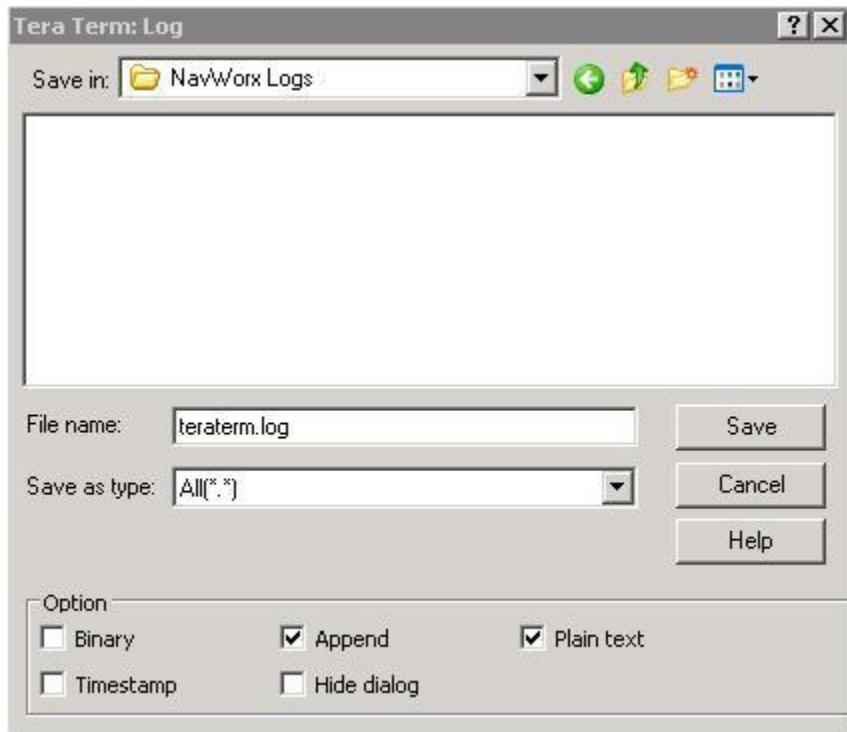

Figure M: LOG ADS600-B OUTPUT TO A FILE

MAINTENANCE PORT TIPS

This section lists ADS600-B maintenance port tips.

- To stop the display of a repeating command press any key “A through Z” and then press enter.
- The ADS600-B maintenance port has no editing functionality (such as backspace, etc.). When a command doesn’t appear to work, press enter several times and then reenter the command.
- A good way to troubleshoot the connection between the terminal emulator software and the ADS600-B is to note whether a key is shown on the terminal display after entering it via the keyboard. The character of the key that is depressed should be displayed on the terminal emulator display. Should a key be depressed at the keyboard and no character is displayed on the terminal emulator display, then either the ADS600-B is not connected to the PC, the terminal emulator baud rate is not configured correctly (baud rate 115200 bps, 8 bits, 1 stop bit, no parity bit, no flow control) or the ADS600-B is not powered on.

MAINTENANCE PORT HELP COMMANDS

Type **HELP** command to get list of available maintenance commands.

READ Commands

| Command | Option | Description |
|---------|---------------|--|
| HELP | | List maintenance commands. |
| READ | ALL | Display all pertinent status and configuration for unit. |
| READ | PORTS | Display mapping of protocol to RS232/RS422 ports. |
| READ | GPS ALL | Display GPS configuration and status. |
| READ | GPS SV | Display GPS service vehicle status. |
| READ | GPS <seconds> | Display GPS statistics at an interval as specified by seconds. |
| READ | ICAO | Display aircraft 24-bit ICAO address. |
| READ | OWNSHIP | Display ownship message. |
| READ | RS232 | Display configuration of RS232 interface. |
| READ | RS422 | Display configuration of RS422 interface. |
| READ | TM <seconds> | Display traffic manager information at an interval as specified by <seconds>. |
| READ | UM <seconds> | Display uplink manager (FIS-B) information at an interval as specified by <seconds>. |

DISPLAY Commands

| Command | Option | Description |
|---------|--|---|
| DISABLE | COMPTIS | Disable Composite-TIS mode. |
| ENABLE | COMPTIS | Enable Composite-TIS mode. |
| MAP | <SKY PASS TA A429S> <RS232 RS422> | Map protocols to physical port. |
| SET | BAUD ARINC429 <LOW HIGH> | Set ARINC429 clock speed. |
| SET | BAUD RS232 <9600 19200 38400 57600 115200> | Set baud rate for RS232 display port. |
| SET | BAUD RS422 <9600 19200 38400 57600 115200> | Set baud rate for RS422 display port. |
| SET | FIS [number] | Set maximum number of FIS-B messages sent to the display. |
| SET | FIS NRST <ALL NRST> | Display FIS-B messages received from nearest ground station or display FIS-B messages received from all ground stations. |
| SET | MAXDIST [x.y] | Set maximum distance in 1/10 th s of a nautical mile for traffic targets. Traffic targets that are greater than this distance from the ownship location will not be passed on to the display(s). |
| SET | MAXALT [feet] | Set maximum vertical distance in feet for traffic targets. Traffic targets that are greater than this distance from the ownship location will not be passed on to the display(s). |
| SET | PROTOCOL <PASS TA A429 SKY NONE> <TISA A429 A429S> | Enter 1 or 2 protocols. |

TRANSMITTER Commands

| Command | Option | Description |
|---------|---|--|
| ENABLE | CSID | Enable call sign identification flag logic. |
| DISABLE | CSID | Disable call sign identification flag logic. |
| ENABLE | PALT | Enable pressure altitude input. |
| DISABLE | PALT | Disable pressure altitude input. |
| ENABLE | TX | Enable UAT transmitter. |
| DISABLE | TX | Disable UAT transmitter. |
| SET | CALLSIGN <1-8 character callsign> | Assign aircraft call-sign. The call-sign may not exceed 8 characters. Must be Alpha-Numeric characters only. No other characters allowed. |
| SET | CAT <NOTYPE LIGHT SMALL LARGE VERYLARGE HEAVY MANEUVERABLE ROTORCRAFT GLIDER LIGHTERTHANAIR PARACHUTIST ULTRALIGHT UAV SPACEVEHICLE EMERGENCY SERVICE POINTOBSTACLE CLUSTEROBSTACLE LINEOBSTACLE> | Assign aircraft category to one of the following categories. |
| SET | GPSANT <left right> <x.y> | Set GPS antenna lateral axis [left or right of centerline] position in meters. |
| SET | GPSANT nose <x.y> | Set GPS antenna longitudinal axis [from nose] position in meters. |
| SET | GS <knots> | Assign speed in knots which determines when aircraft is airborne. |
| SET | ICAO <hexadecimal> | Assign the aircraft's ICAO address in a hexadecimal format. http://www.smalluas.com/download/ICAO_Annex_10_Volume_III.pdf |
| SET | LENGTH <x.y> | Set length of aircraft in meters. |
| SET | WIDTH <x.y> | Set width of aircraft in meters. |

TRANSMITTER (Pilot Input) Commands

| Command | Option | Description |
|---------|---|---|
| SET | EMERGENCY <NONE GENERAL MEDICAL MINFUEL NOCOMM HIJACK ACFTDOWN> | Set emergency code. |
| SET | FLIGHTID O:<octal-number> | Set flight ID as an octal 4 to 6 digit number. E.g. SET FLIGHTID O:1200 |
| IDENT | | Start IDENT. Mode status message is transmitted for 20 +/- 4 seconds. |
| ENABLE | SAA | Enable transmission of the temporary self-assigned address. The self-assigned address will be transmitted instead of the ICAO address. |
| DISABLE | SAA | Disable transmission of the temporary self-assigned address. The ICAO address will be transmitted instead of the self-assigned address. |

UTILITY Commands

| Command | Option | Description |
|----------------|-------------------|---|
| RESET | | Reset unit. |
| ENABLE | SIM | Enable simulation mode. |
| DISABLE | SIM | Disable simulation mode. |
| SET | GPSSRC <INT A743> | Set source of GPS: internal or external (ARINC 743A). |
| SET | LOADER | Used for updating unit software. |

VERIFYING ADS600-B CONFIGURATION

- ✓ Power up the ADS600-B.
- ✓ Type “READ ALL” on TeraTerm input.
- ✓ Observe the output on the TeraTerm monitor. This output is saved to a log file that you specified above when logging was enabled.
 - Verify the ICAO address. If the ICAO address is not correct, set the address using the **SET ICAO <hexadecimal number>** as described in the [CONFIGURING ICAO ADDRESS](#) section.
 - Verify the aircraft category. If the aircraft category is incorrect, set the category using the **SET CAT <category>** command as described in the [MAINTENANCE PORT HELP COMMANDS](#).
 - Verify the aircraft callsign. If the aircraft callsign is incorrect, set the callsign using the **SET CALLSIGN <8 characters>** command as described in the [MAINTENANCE PORT HELP COMMANDS](#).
 - Verify that the flight ID is set to 1200. If the flight ID is not set to 1200, use **SET FLIGHTID O:<octal number>** command as described in the [MAINTENANCE PORT HELP COMMANDS](#).
 - Verify that the transmitter is enabled. **WARNING: If the transmitter is enabled, the UAT antenna must be connected to the ADS600-B; otherwise damage to the ADS600-B will occur and your warranty will not be honored.** If the transmitter is not enabled, use the **ENABLE TX** command as described in the [MAINTENANCE PORT HELP COMMANDS](#).
 - If a pressure altitude encoder is connected to the ADS600-B, the output of **READ ALL** command will indicate the PRIMARY SOURCE is PRESSURE and the SECONDARY SOURCE is GEOMETRIC.
- ✓ Type **READ GPS ALL** command. The [DETERMINING GPS RECEPTION](#) section describes how to interpret the GPS reception status. Verify that the ADS600-B reports good GPS reception.

Interconnect Diagram: ADS600 to GPSMAP® TIS-A

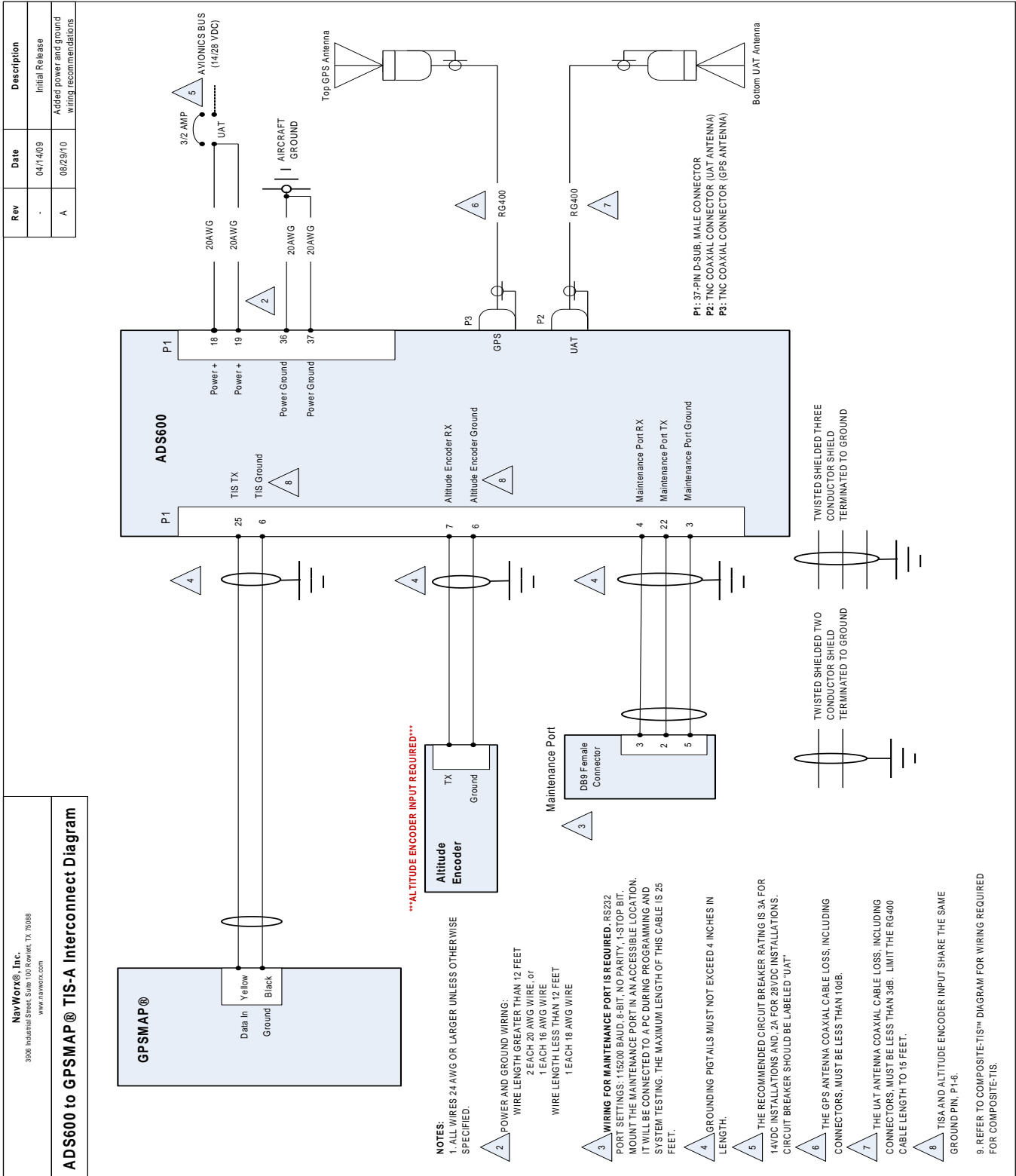

Interconnect Diagram: Bluetooth Display Port

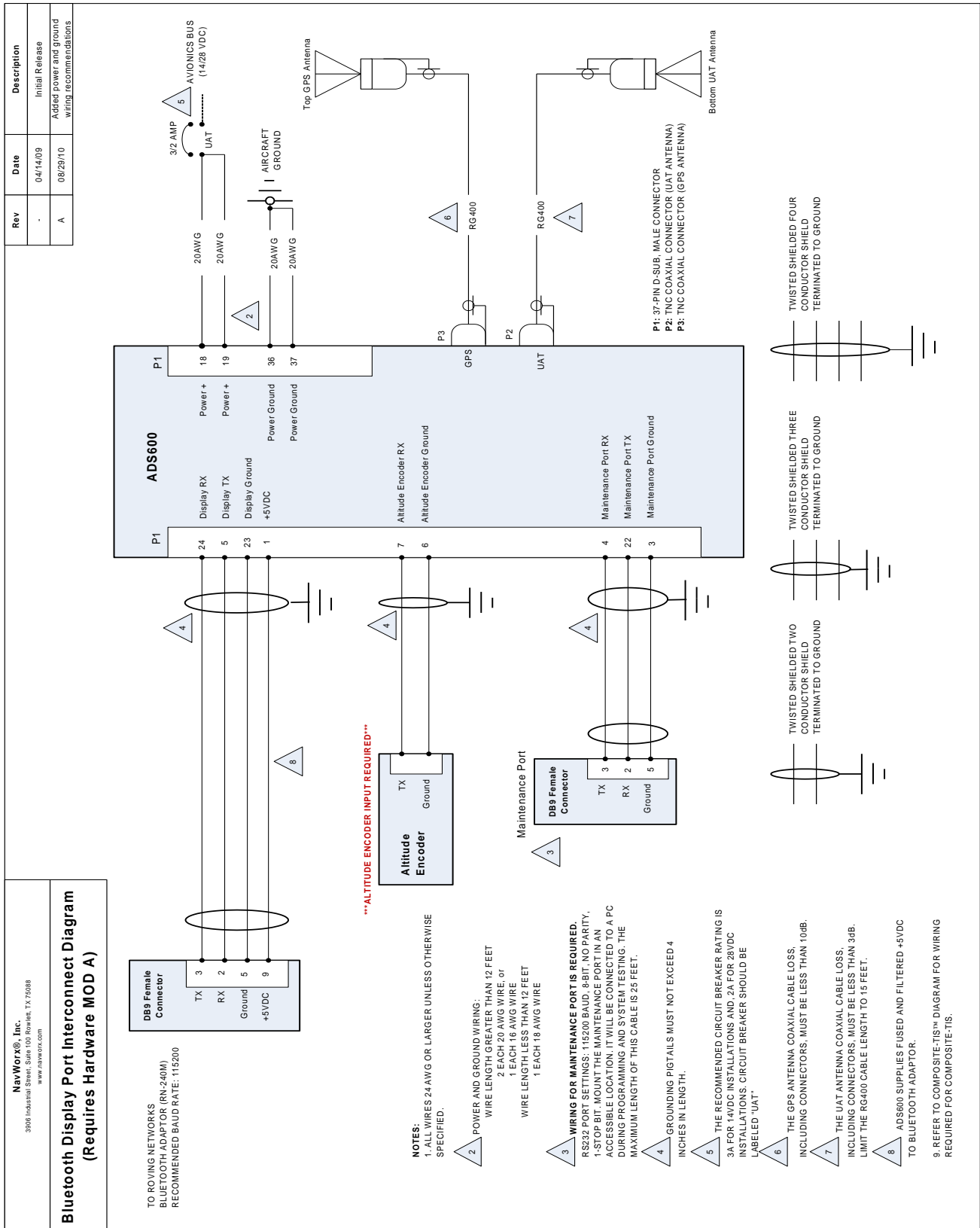

Interconnect Diagram: Display Port

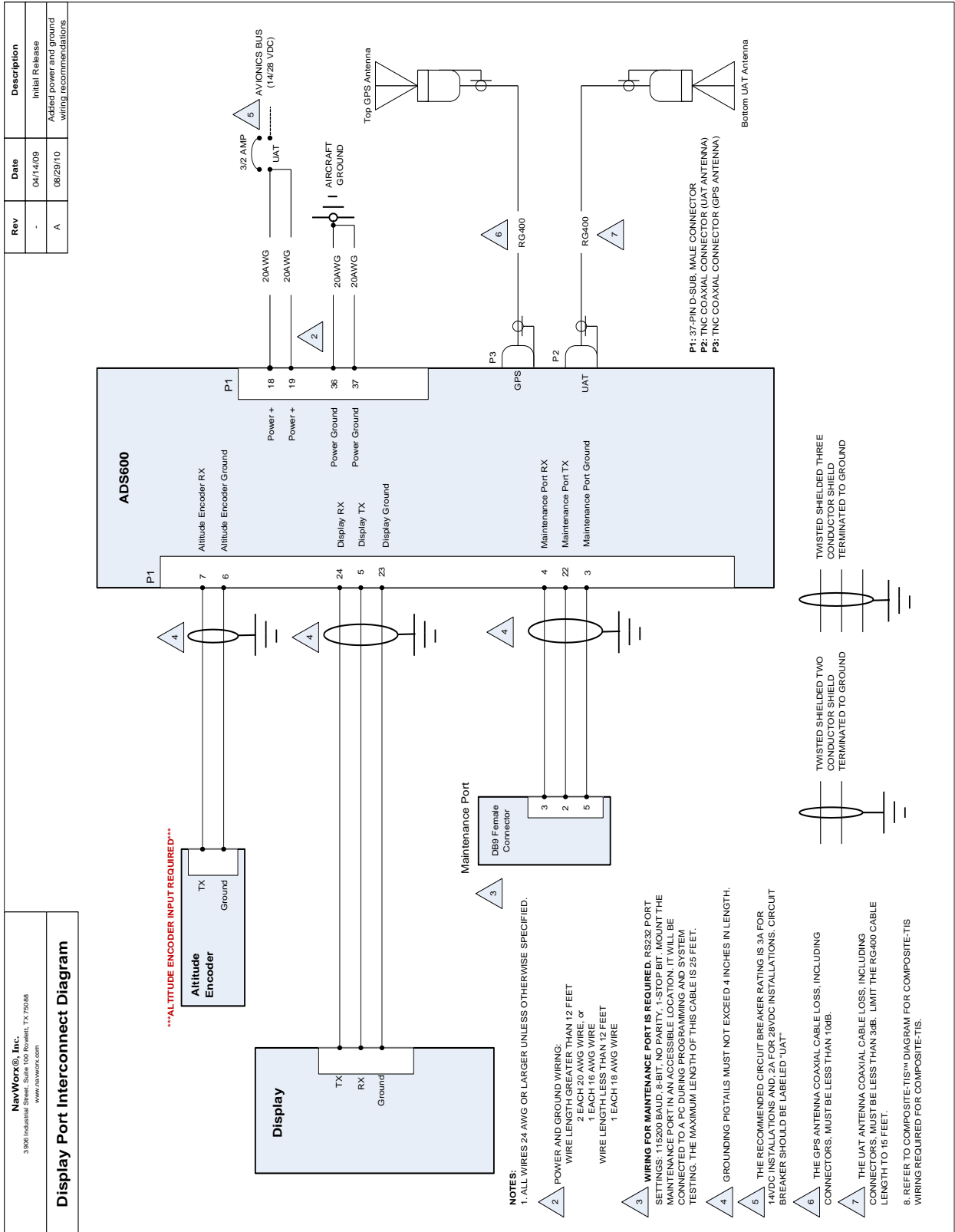

ADS600 Maintenance Port to Computer Interconnect Diagram

Interconnect Diagram: ADS600 Maintenance Port to Computer

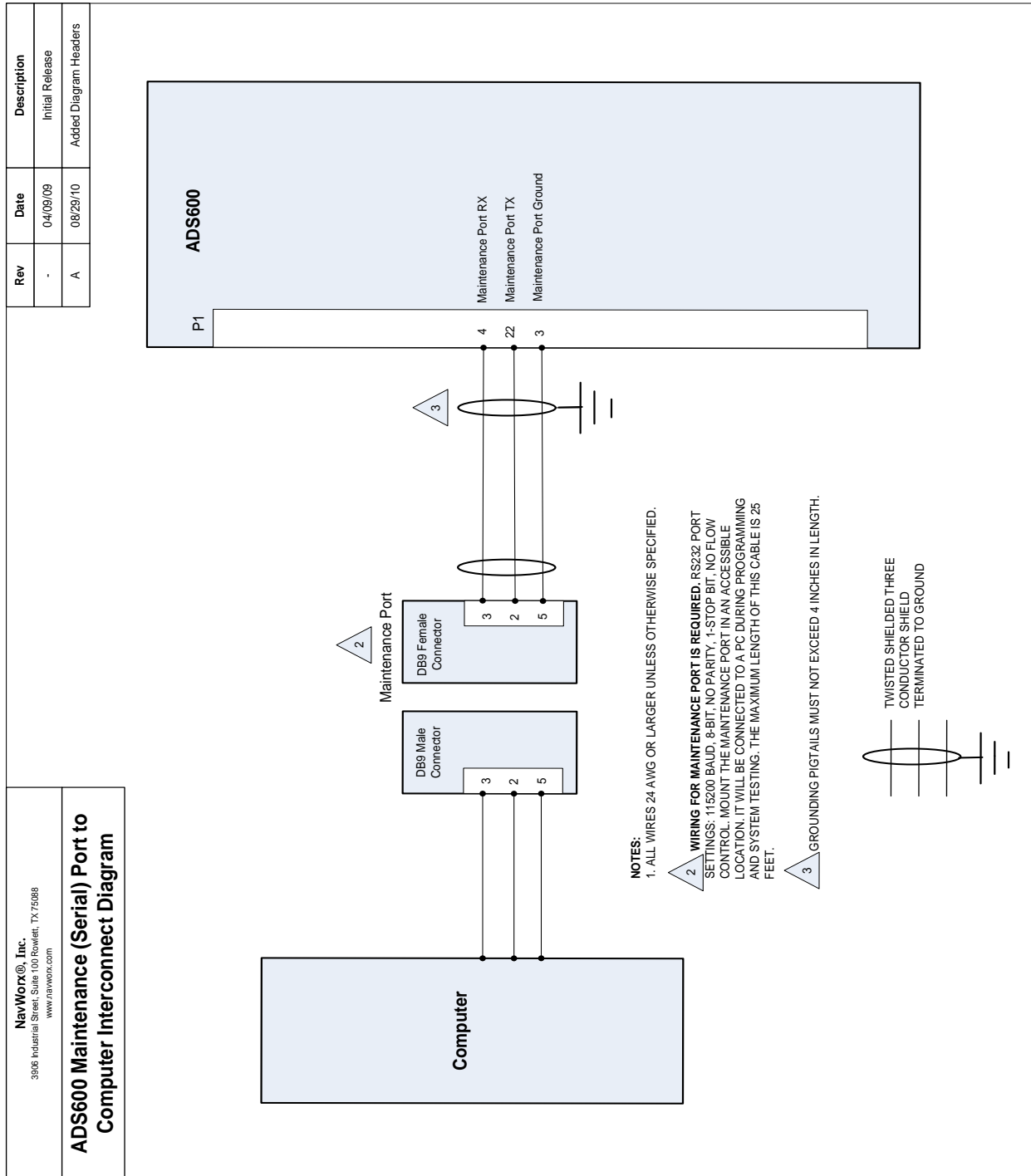

Interconnect Diagram: Composite-TIS™

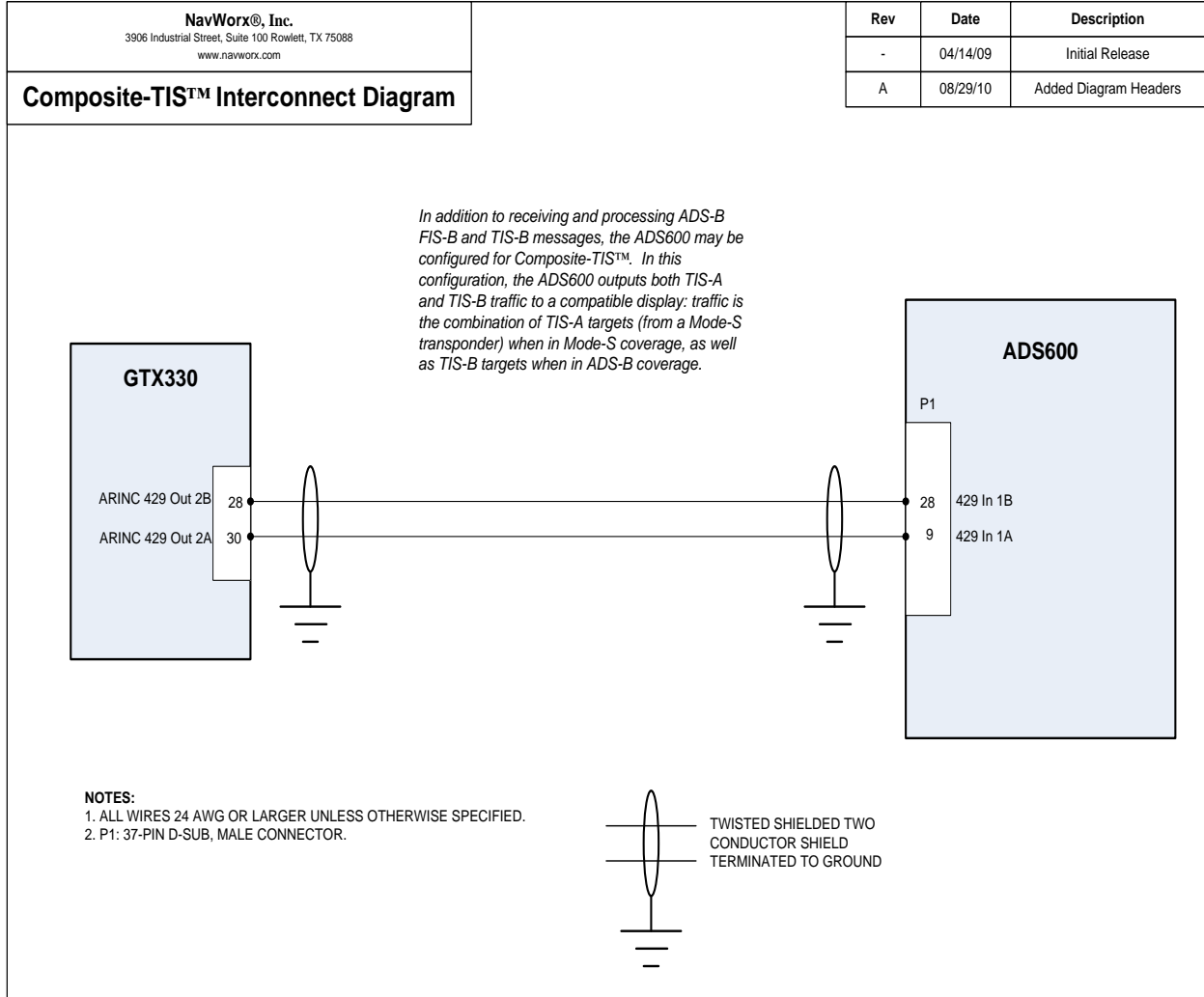

Interconnect Diagram: ADS600 to AFS (TIS Traffic)

| Rev | Date | Description |
|-----|----------|---|
| - | 04/14/09 | Initial Release |
| A | 08/29/10 | Added power and ground wiring recommendations |

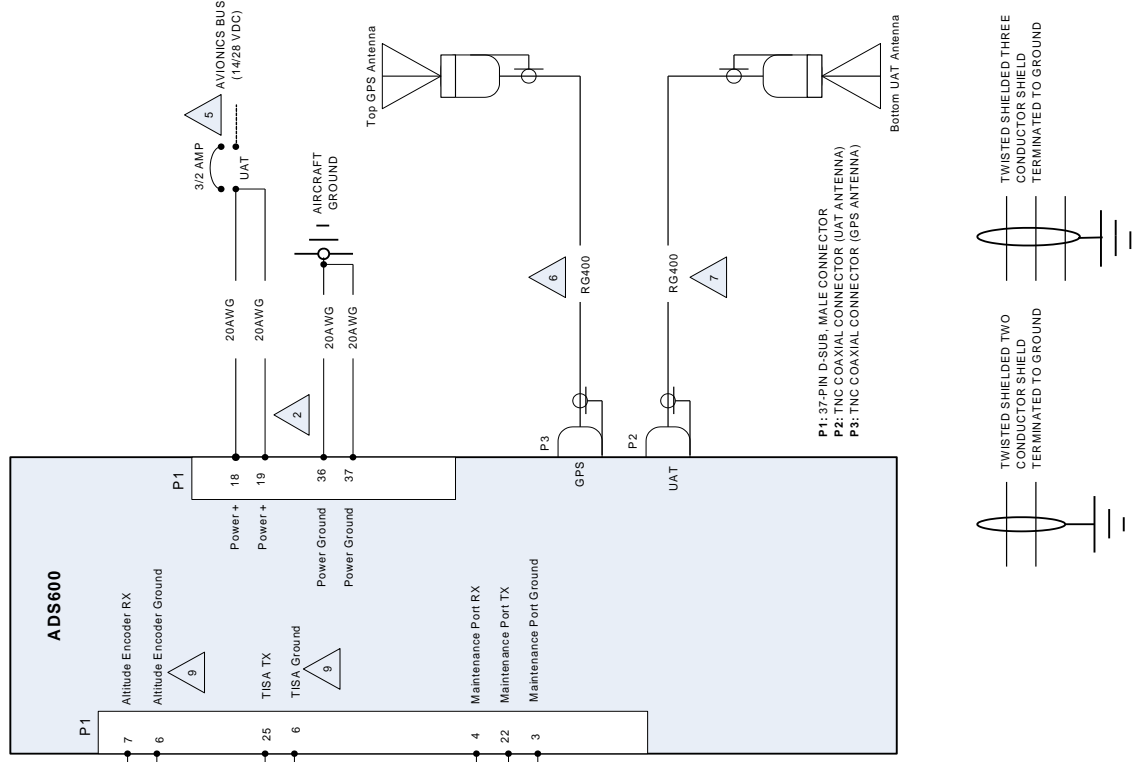

NavWorx® Inc.
3906 Industrial Street, Suite 100 Rowlett, TX 75088
www.navworx.com

ADS600 to AFS Interconnect Diagram TIS Traffic Interface

ALTIITUDE ENCODER INPUT REQUIRED

- NOTES:**
1. ALL WIRES 24 AWG OR LARGER UNLESS OTHERWISE SPECIFIED.
 2. POWER AND GROUND WIRING:
WIRE LENGTH GREATER THAN 12 FEET
2 EACH 20 AWG WIRE, or
1 EACH 16 AWG WIRE
1 EACH 18 AWG WIRE.
 3. **WIRING FOR MAINTENANCE PORT IS REQUIRED.** RS232 PORT SETTING (500K BAUD), 8 DATA BITS, STOP BIT LENGTH THE SAME AS THE MAINTENANCE PORT. ACCESSIBLE LOCATION WILL BE CONNECTED TO A PC DURING PROGRAMMING AND SYSTEM TESTING. THE MAXIMUM LENGTH OF THIS CABLE IS 25 FEET.
 4. GROUNDING PIGTAILS MUST NOT EXCEED 4 INCHES IN LENGTH.
 5. THE RECOMMENDED CIRCUIT BREAKER RATING IS 3A FOR 14VDC INSTALLATIONS AND .2A FOR 28VDC INSTALLATIONS. CIRCUIT BREAKER SHOULD BE LABELED "UAT".
 6. THE GPS ANTENNA COAXIAL CABLE LOSS, INCLUDING CONNECTORS, MUST BE LESS THAN 1.0dB.
 7. THE UAT ANTENNA COAXIAL CABLE LOSS, INCLUDING CONNECTORS, MUST BE LESS THAN 3dB. LIMIT THE RG400 CABLE LENGTH TO 15 FEET.
 8. AFS PROVIDES 4 SERIAL PORTS THAT ARE CAPABLE OF DISPLAYING TRAFFIC (PORT 1: RX-PIN 22, GROUND-PIN 9, PORT 2: RX-PIN 25, GROUND-PIN 21, PORT 3: RX-PIN 5, GROUND-PIN 21, PORT 4: RX-PIN 6, GROUND PIN 9).
 9. TISA AND ALTIITUDE ENCODER INPUT SHARE THE SAME GROUND PIN, P1-6.
 10. REFER TO COMPOSITE-TIS™ DIAGRAM FOR WIRING REQUIRED FOR COMPOSITE-TIS.

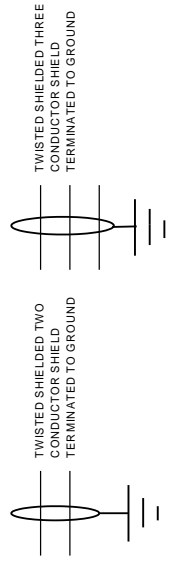

Interconnect Diagram: ADS600-B to GRT

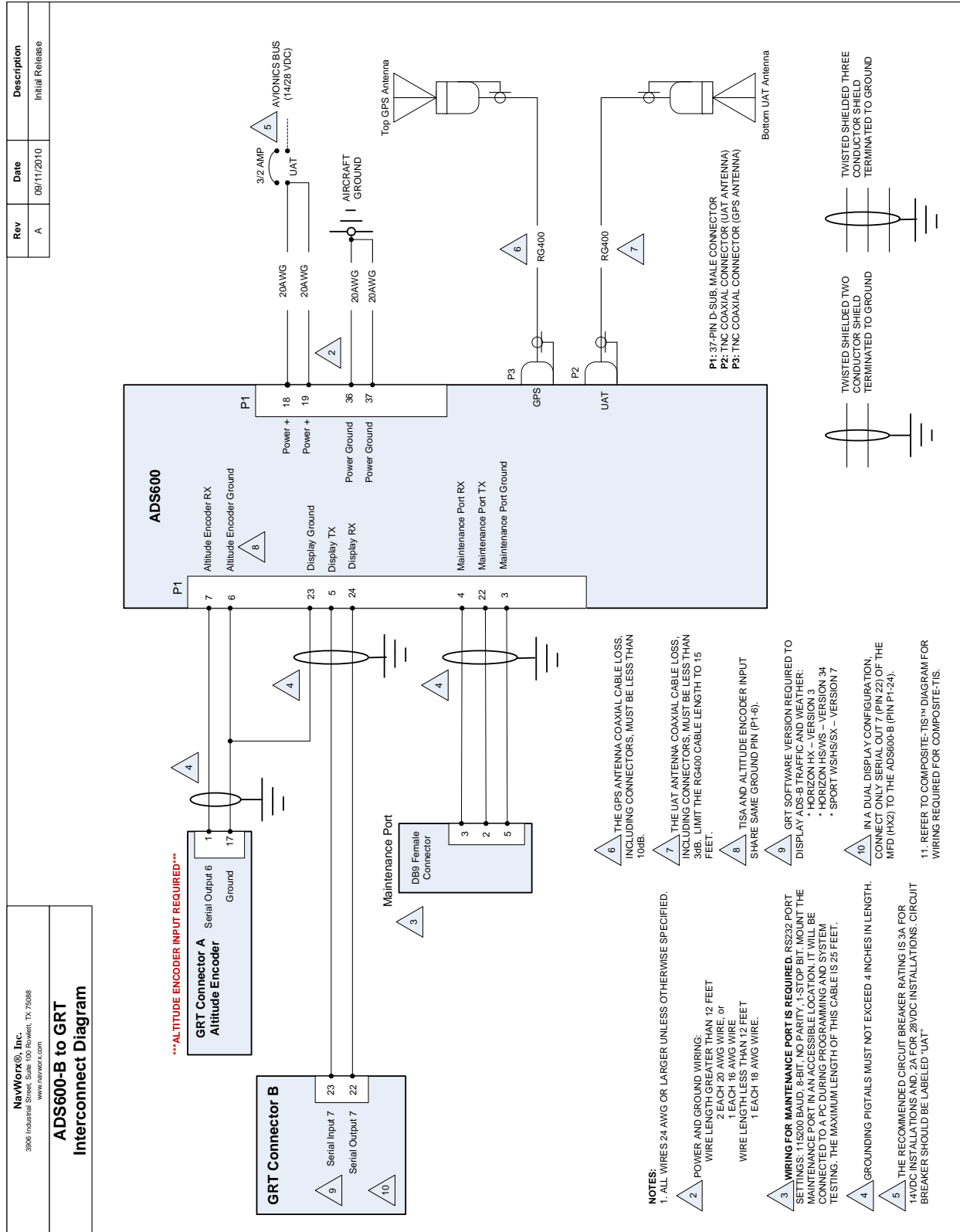

Interconnect Diagram: ADS600-B to GRT HX/HS/WS (TIS Traffic)

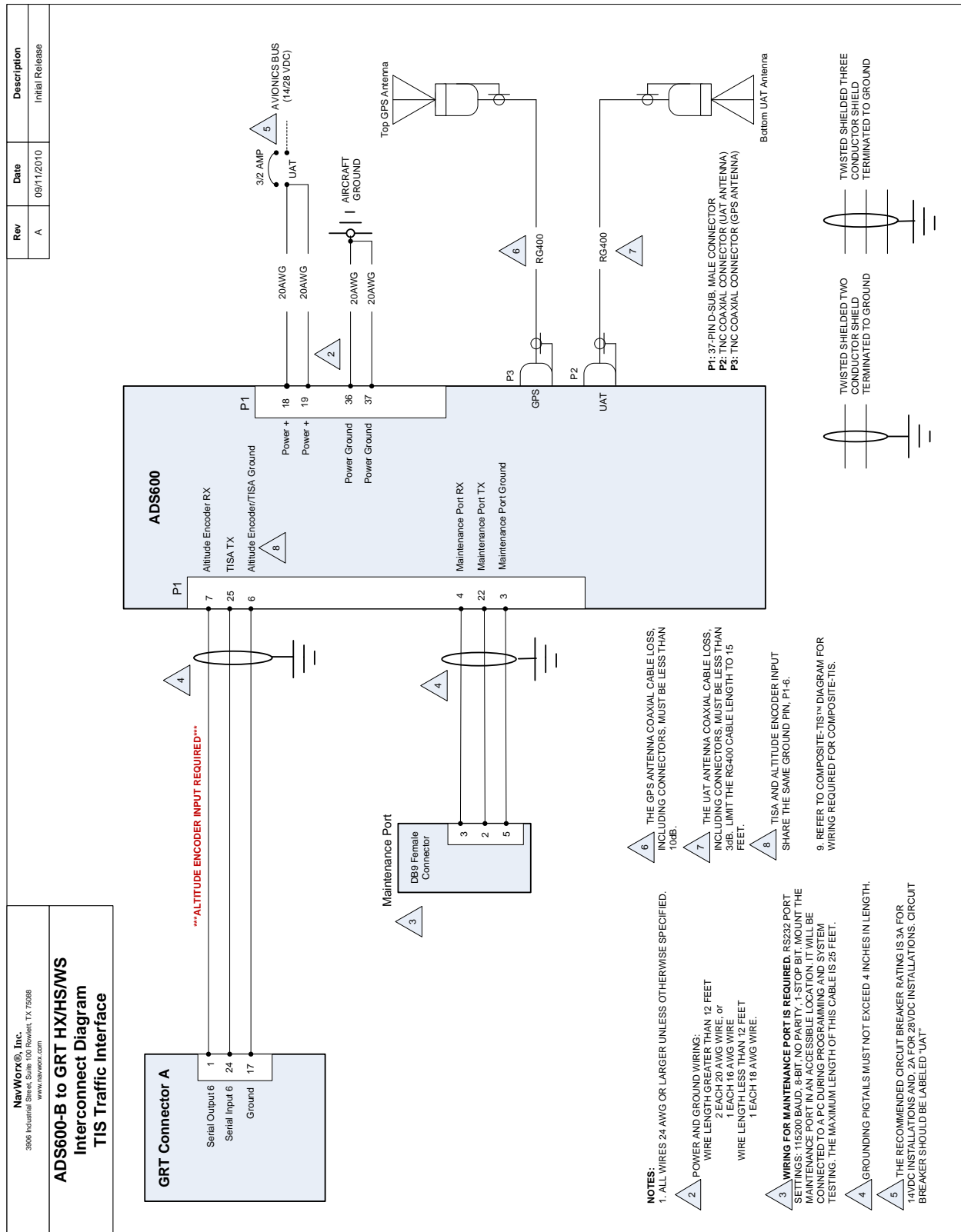

Interconnect Diagram: GNS 480 ARINC 743A Position Source

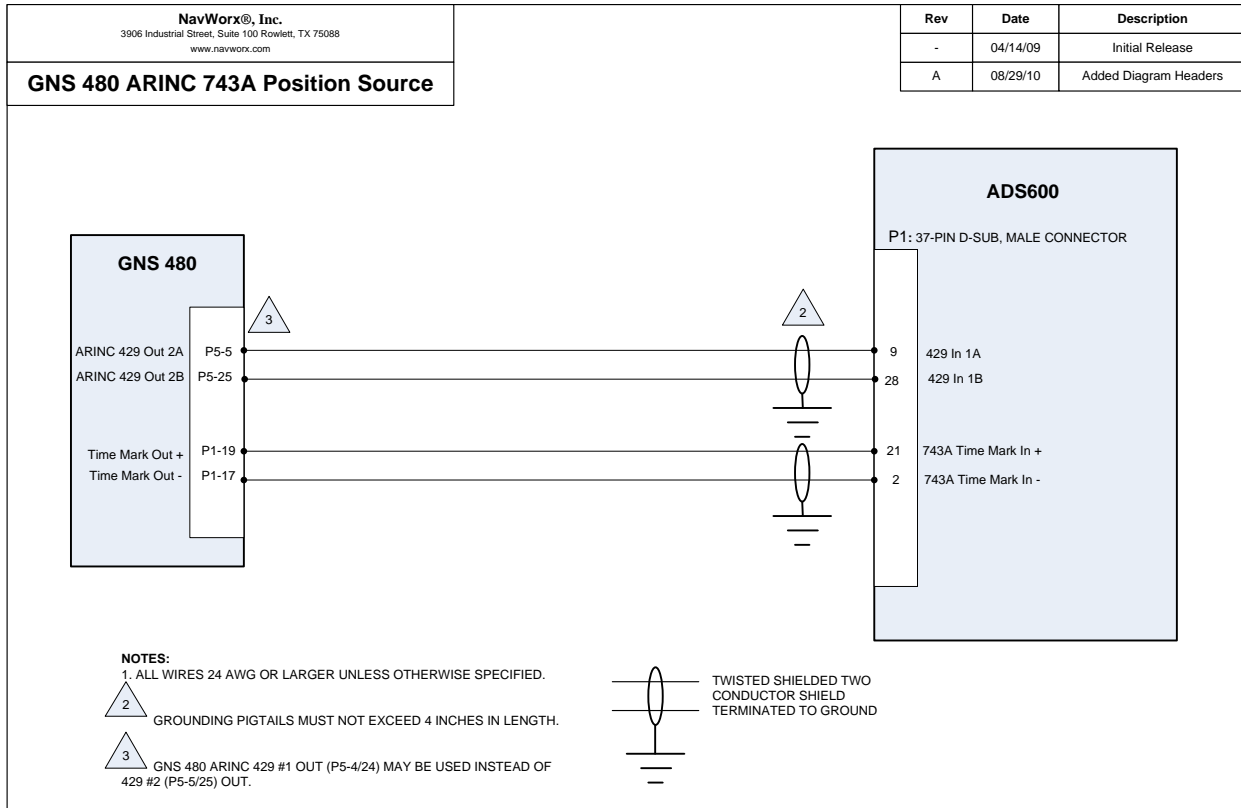

Interconnect Diagram: ADS600-B to GNS 480 Traffic (ARINC 429)

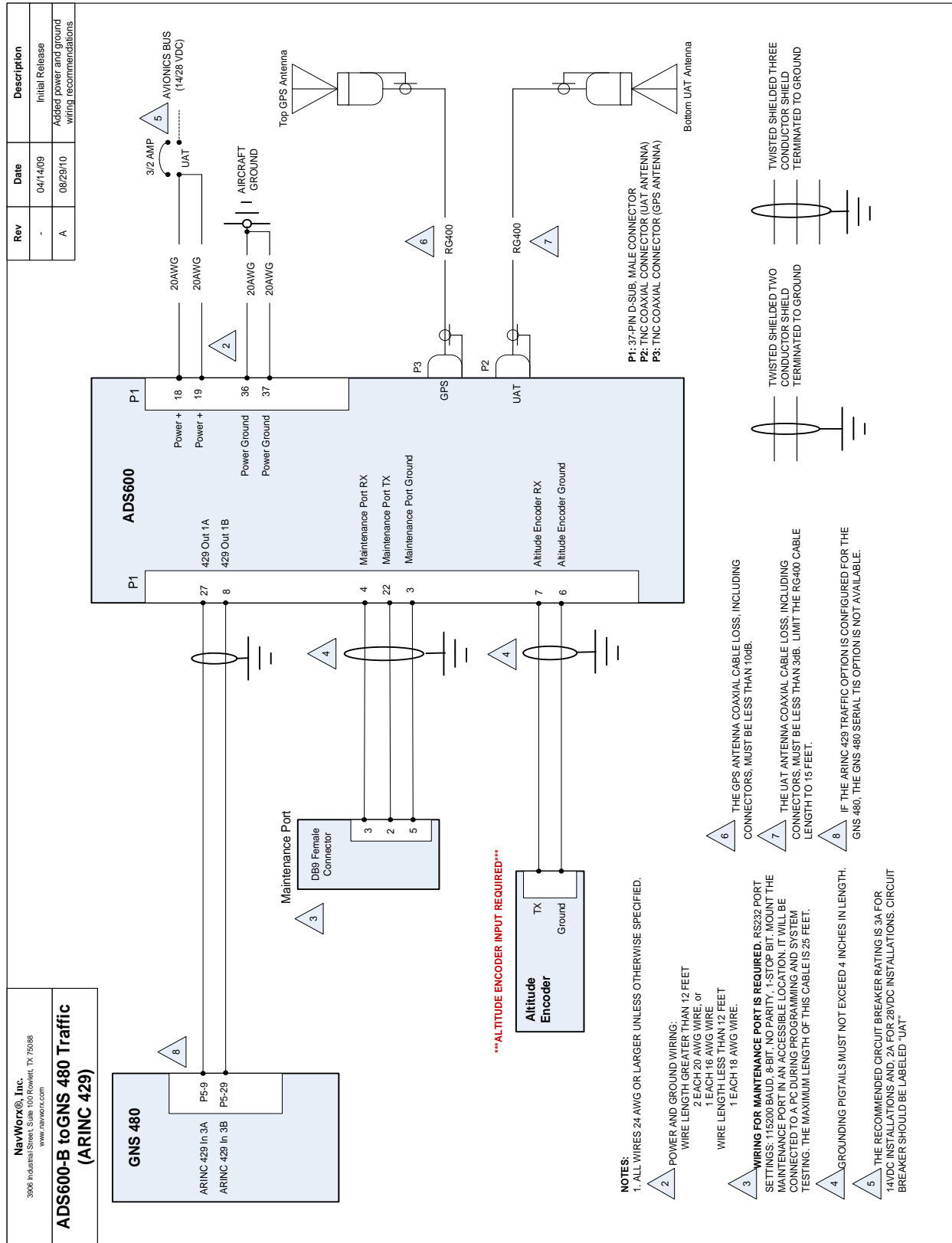

Interconnect Diagram: ADS600-B to GNS 480 Traffic (RS-232 TIS)

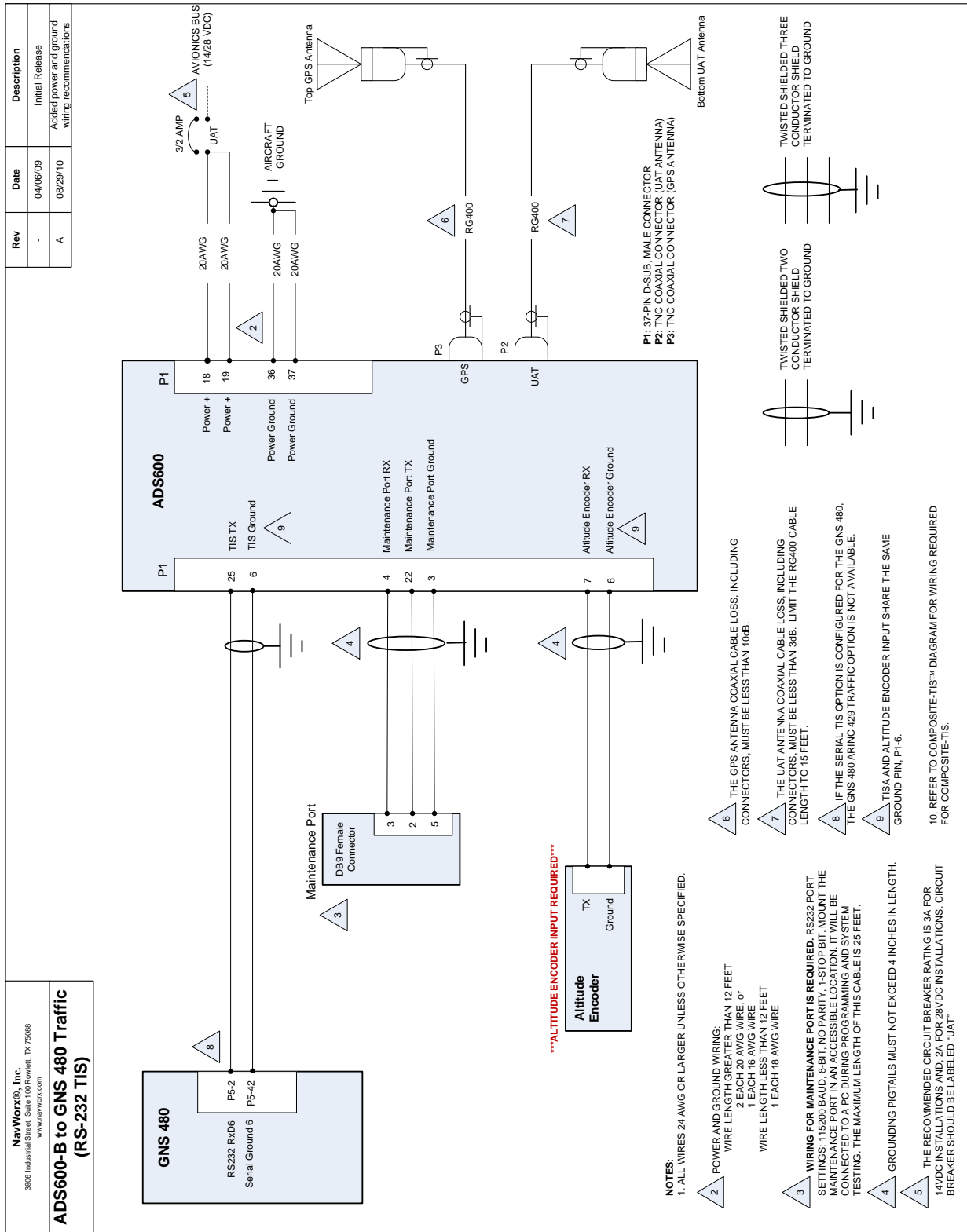

Interconnect Diagram: ADS600-B to GNS 430 Traffic (ARINC 429)

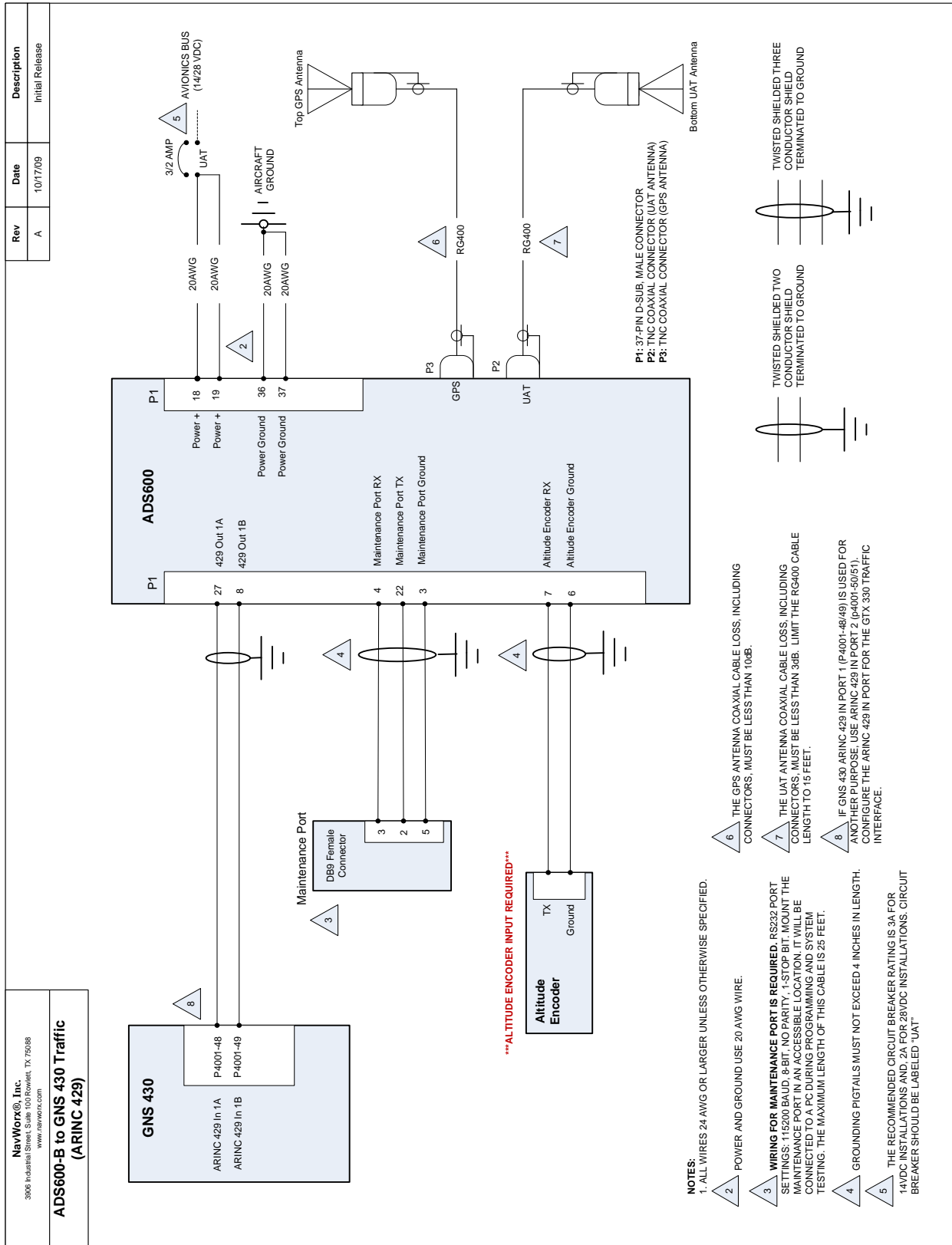

Interconnect Diagram: ADS600 to Chelton

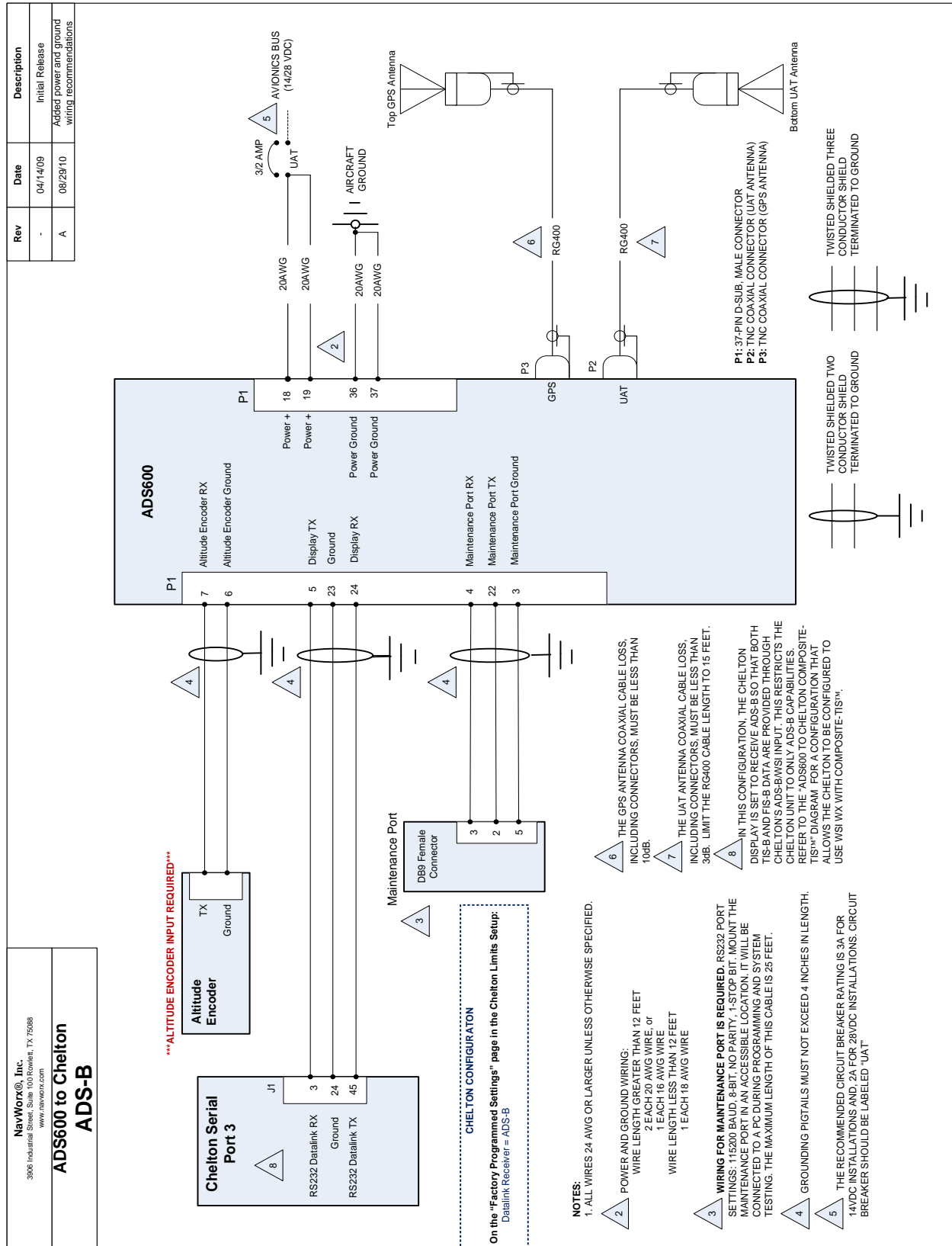

Interconnect Diagram: ADS600 to Chelton (Composite TIS™)

