

AR850 ALTITUDE REPORTER  
(L/C) 30,700ft

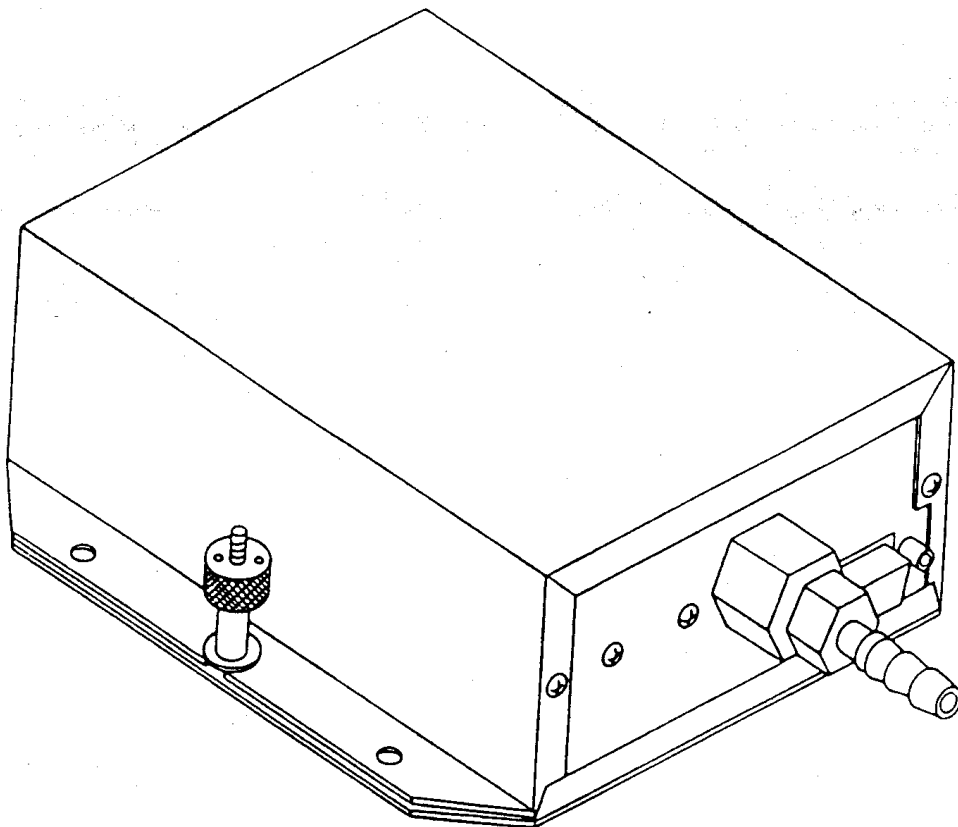

INSTALLATION/OPERATION MANUAL  
30,700 FEET  
MANUAL PART NO. 03753-0623

◆<sup>®</sup> NARCO AVIONICS INC.  
270 COMMERCE DRIVE  
FORT WASHINGTON, PENNSYLVANIA, 19034  
U.S.A.

©COPYRIGHT, NARCO AVIONICS INC., 1990

NOTICE

While every effort has been made by Narco Avionics Inc. to ensure accuracy in the preparation of this Installation Manual, Narco assumes no responsibility for errors or omissions.

NARCO AVIONICS INC. CAN BE REACHED BY CALLING:

PHONE: 215-643-2900

FAX: 215-643-0197

CUSTOMER SERVICE LINE: 215-643-2905

TABLE OF CONTENTS

SECTION	TOPIC	PAGE
1.1	Introduction .....	1-1
1.1.1	Manual Organization .....	1-1
1.2	Product Description .....	1-1
1.3	Design Features .....	1-2
1.4	Product Specifications .....	1-2
1.5	Ordering Information for units/accessories .....	1-4
1.6	Licensing Requirements .....	1-4
1.7	TSO Explanation .....	1-5
1.8	Environmental Qualification Form .....	1-7
2.1	Introduction .....	2-1
2.2	Preliminary Procedures .....	2-1
2.2.1	Preliminary Inspection .....	2-1
2.2.2	Preliminary Bench Check .....	2-1
2.3	Mechanical Installation .....	2-3
2.4	Electrical Installation .....	2-9
2.4.1	AR850 to Transponder Compatibility .....	2-9
2.4.2	AR850 ENABLE Requirements .....	2-9
2.4.3	Primary Power Requirement .....	2-10
2.4.4	AR850 Altitude Code Line Characteristics .....	2-10
2.4.5	Interconnect Cable Fabrication .....	2-11
2.4.6	Correspondence Test .....	2-12
2.4.6.1	Test Equipment Requirements .....	2-12
2.4.6.2	Test Procedure .....	2-12
2.4.7	Interconnect Wiring Diagrams .....	2-14
2.4.7.1	AR850 to AT155/AT150/AT50/50A Installation .....	2-14
2.4.7.2	AR850 to KING KT76/78 .....	2-15
2.4.7.3	AR850 to KING KT76A/78A/79 .....	2-16
2.5	Post Installation Tests .....	2-17
2.5.1	Preflight Tests .....	2-17
3.1	General .....	3-1
3.2	Operation .....	3-1

#### LIST OF ILLUSTRATIONS

FIGURE NO.	TITLE	PAGE
2-1	Bench Test Set-up .....	2-1
2-2	AR850 Mechanical Dimensions .....	2-4
2-3A	AR850 Tray Template .....	2-5
2-3B	AR850 Case Template .....	2-7
2-4	P101 Assembly .....	2-11
2-5	P101 Pin Assignments .....	2-12
2-6	AR850 to AT155/AT150/AT50/50A Interconnections .....	2-14
2-7	AR850 to KT76/78 Interconnections .....	2-15
2-8	AR850 to KT76A/78A/79 Interconnections .....	2-16

THIS PAGE LEFT INTENTIONALLY BLANK

## 1.1 INTRODUCTION

In support of the Narco Avionics AR850 Altitude Reporter, this manual provides detailed installation and maintenance procedures. This manual is intended for use by persons who are qualified to service the equipment described in this manual pursuant to current regulatory requirements.

### 1.1.1 MANUAL ORGANIZATION

Organized into three sections, this manual provides the following:

- |           |   |
|-----------|---|
| SECTION 1 | GENERAL INFORMATION - Product description, ordering information, specifications, environmental category and licensing requirements.           |
| SECTION 2 | INSTALLATION - Detailed information for performing the mechanical and electrical installation.  |
| SECTION 3 | OPERATION - Operation of the AR850 system is covered only to the extent of making the electrical tests necessary to confirm proper operation. |

NOTE : Maintenance Manuals are not available to the field because all maintenance not covered in this installation manual must be performed at the factory for the following reasons :

1. Sensor Scaling selected parts.
2. Special Programmed PROM for linearization of the sensor output.

## 1.2 PRODUCT DESCRIPTION

The AR850 Altitude Reporter is a TSO'd pressure altitude digitizer. Sensing atmospheric pressure, the AR850 converts pressure/altitude information into digitized altitude data, ready for transmission to air traffic control centers via the aircraft's transponder during a Mode C interrogation.

The AR850 L/C (30,700 ft.) differs from the 25,000 and 30,700 ft. versions in mechanical packaging and altitude limit only. The pin out (because of the smaller connector) is different from the original model. The electronics remain the same.

The AR850 L/C (30,700 ft.) is not pin compatible and requires different mounting holes than Narco's older AR500 Altitude Reporter.

1.3 DESIGN FEATURES

- Reports altitude up to 30,700 feet (9,357 meters).
- Incorporates a Piezoresistive pressure sensor.
- No complex gears, shafts or optical discs are used which increases the unit's reliability.
- Directly compatible with most current production transponders.
- Meets FAA TSO C88(a).
- Lightweight: less than 1 pound.
- Compact: Remote mounts easily within the aircraft's structure.
- Operates on either 14 or 28 Vdc.

1.4 PRODUCT SPECIFICATIONS

ALTITUDE REPORTING RANGE

-1,000 to 30,700 feet referenced to 29.92 inches of mercury.

CODE OUTPUT

The digitized output format is in accordance with the U.S. National Standard for Common System Component Characteristics for the IFF Mark X (SIF)/Air Traffic Control Radar Beacon System, SIF/ATCRBS as amended December 27, 1963 and is the same code specified in the International (ICAO) Standard Code for SSR Pressure Altitude Transmission.

ACCURACY

The digitizer reproduces the pressure altitude in digital form with a tolerance of  $\pm 50$  feet referenced to 29.92 inches of mercury as measured at any transition point of the digital code over the range of -1,000 to 30,700 feet, as shipped from the factory.

MECHANICAL

SIZE : See UNIT DIMENSIONS on page 2-4.

WEIGHT : AR850 Unit 0.7 lbs. ( 0.318 kg.)  
AR850 Tray 0.090 lbs. (0.041 kg.)

1.4 PRODUCT SPECIFICATIONS, Continued

ELECTRICAL

INPUT POWER : 11 to 32 Vdc at 1.4 amps maximum during  
the first 3 minutes of operation. 0.35  
amps average after 3 minutes of operation.

ENVIRONMENTAL

TSO C88 (a)

DO160B ENVIRONMENTAL CATAGORY B1B/A/NOM/XXXXXXBBBBBB

CODE LINE OUTPUT CHARACTERISTICS

Data bit outputs are compatible with DTL, TTL, MOS,  
CMOS, ECL or any other logic interface requiring the  
following characteristics:

BIT OFF OUTPUT STATE : Will accept from the transponder  
a voltage pullup of +50 Vdc at a leakage current of 100  
microamps.

BIT ON OUTPUT STATE : 0.75 Vdc at 50 ma. Sinking  
current  
1.1 Vdc at 100 ma. sinking  
current

DIGITIZER ENABLE SIGNAL INPUT

The AR850 will accept continuous type digitizer enable signal  
information.

DIGITIZER ENABLED:

1. J101-6 : When pin 6 is grounded the digitizer is  
enabled.

DIGITIZER INHIBITED:

1. J101-6 : When pin 6 is open circuited or a DC  
voltage greater than 0.5 volts is applied, the  
digitizer is inhibited.

NARCO AVIONICS AR850

1.5 ORDERING INFORMATION FOR UNITS AND ACCESSORIES

The following list identifies the AR850 system and the order number to use to obtain the complete system. The accessory items of the system may be ordered by using the part numbers listed opposite the item.

Item No.	Order No.	Description	Accessory/ Individual Part No.
1	03753-0306	AR850 L/C (30,700 ft.) With : Installation Kit Environmental Qualification Form (03753-0621) (DOES <u>NOT</u> INCLUDE MOUNTING TRAY)	01447-0103
		ACCESSORIES :	
		Mounting Tray Kit	03753-0305
		Installation Kit	03753-0503
	Quantity	Installation Kit :	
2	1	15 Pin Connector (P101)	41364-0004
3	1	Connector Hood (P101)	41307-0011
4	15	Connector Pins (P101)	41372-0010
6	2	Screw, 4-40 x 5/8	84536-0708
7	1	Cockpit Label, 30,700 ft.	04968-0001

1.5.1 Miscellaneous Items Required but Not Supplied:

1. Sufficient length of #22 AWG stranded hook-up wire
2. A resettable circuit breaker or fuse rated at 2 amps for device protection.
3. Sufficient length of 1/4 inch ID hosing to connect to the AR850's plastic static adapter for venting to atmosphere.
4. Mounting Hardware.

1.6 LICENSING REQUIREMENTS

There are no operator or aircraft license requirements for this type of equipment.



1.7 TSO EXPLANATION

The AR850 is designed to be remote mounted within a non-pressurized but controlled temperature location within an aircraft that is operated up to 30,700 MSL.

This equipment requires direct current power, but may be installed in aircraft having additional on-board alternating current sources.

There are 18 "Environmental Test Procedures" established in RTCA Document DO-160B, dated July 1984. These are identified on the TSO Nameplate. The following identifies the Environmental Categories to which the AR850's are designed, the sections of DO-160B covering the test procedures, and an explanation of each category.

Temperature and Altitude (Section 4.0 Rev. 1)																				
Temperature Variation (Section 5)																				
Humidity (Section 6)																				
Vibration (Section 8)																				
Explosion (Section 9)																				
Waterproofness (Section 10)																				
Fluid Susceptibility (Section 11)																				
Sand and Dust (Section 12)																				
	B1/B/A/NMO/X	X	X	X	X	X	X	X	X	Z	B	B	B	B	B	B	B	B	B	B
Fungus Resistance (Section 13)																				
Salt Spray (Section 14)																				
Magnetic Effect (Section 15)																				
Power Input (Section 16)																				
Voltage Spike (Section 17)																				
Audio Frequency Conducted Susceptibility (Section 18)																				
Induced Signal Susceptibility (Section 19)																				
Radio Frequency Susceptibility (Section 20)																				
Emission of Radio Frequency Energy (Section 21)																				

\* AR850 also tested for shock operation (Sections 7, 7.2, 7.3).

Temperature and Altitude - Category B1

Temperature, Operating:

Low Operating Temperature	-20°C (-4°F)
High operating Temperature	+55°C (+131°F)
Short Time Operating Temperature, High	+70°C (+158°F)

Temperature, Non-Operating:

Ground Survival Temperature, Low	-55°C (-67°F)
Ground Survival Temperature, High	+85°C (+185°F)

Altitude, Non-Pressurized: 7,620 M (25,000 ft.)

Temperature Variation - Category B

Low Operation (-20°C) to  
High Operation (+55°C).

Temperature may vary between  
high and low limits at a  
rate of 5 degrees C minimum  
per minute.

Humidity - Category A

These limits have been tested under the Standard Humidity Environment of: +50°C (+122°F) at 95% relative humidity, reduced to +38°C (+100°F) with a relative humidity maintained in excess of 85%.

This cycle was repeated twice for a total of 48 hours of exposure. Within 15 minutes after exposure, the units were operated and met all specifications.

[TSO requires that all specifications be met within 4 hours after exposure.]

Vibration - Category NMO

Maximum vibration limits are:

- 0.100" double amplitude from 5 Hz. to 17 Hz.
- 1.5 G constant acceleration from 17 Hz. to 500 Hz.
- 0.5 G constant acceleration from 500 Hz. to 2000 Hz.

Not Applicable - Category X

The following six Environmental Conditions do not normally exist in Civil Aircraft, when recognized installation practices are adhered to and are, therefore, not tested.

- Explosion - Category X
- Waterproofness - Category X
- Hydraulic Fluid - Category X
- Sand and dust - Category X
- Fungus Resistance - Category X
- Salt Spray - Category X

Magnetic Effect - Category Z

With this equipment operating, it may be placed at a distance less than 0.3 meter from a free magnet with a 1° or less deflection of the magnet.

Power Input - Category B

This equipment is designed for use in aircraft electrical systems supplied by an engine driven alternator/rectifiers or DC generator with a battery of significant capacity floating on the DC bus at all times.

	<u>28V System</u>	<u>14V System</u>
Normal Operating Conditions (Vdc) are:		
Maximum	30.3	15.1
Nominal	27.5	13.8
Minimum	24.8	12.4

Voltage Spike - Category B

This equipment has been designed to withstand the transient voltage characteristics specified by RTCA Document DO-160B.

Audio Frequency Conducted Susceptibility - Category B

This equipment has been designed and tested to assure compliance with the requirements of RTCA Document DO-160B.

Induced Signal Susceptibility - Category B

This equipment has been designed to withstand the effects of audio frequency electric and magnetic fields and induced voltage spikes as specified by Category B.

Radio Frequency Susceptibility - Category B

This equipment has been tested and is not affected by interference from other on-board electronic equipment which meet Category B, Emission of Radio Frequency Energy Test of RTCA Document DO-160B.

Emission of Radio Frequency Energy - Category B

This equipment has been tested and does not emit radio frequency energy in excess of that specified.

1.8 ENVIRONMENTAL QUALIFICATION FORM

An Environmental Qualification Form (Number 03753-0621) is included with each AR850 shipped from the factory. This two page form identifies the TSO categories to which the AR850 was designed and tested as outlined in RTCA Document DO-160B dated July 1984.

The installing agency must ensure that the owner of the AR850 is given this form which he should place in his avionics equipment file.

THIS PAGE INTENTIONALLY LEFT BLANK

2.1 INTRODUCTION

This section provides all the electrical and mechanical installation information. Electrical and Mechanical Installation sections are independent and self-supporting. This permits their removal from the manual allowing the electrical and mechanical installation efforts to proceed in parallel.

2.2 PRELIMINARY PROCEDURES

2.2.1 Preliminary Inspection

Carefully unpack the equipment, noting any damage to shipping cartons or avionics. If damage is noted, retain the cartons to corroborate damage claims.

Inventory the received items against the lists in Section 1.5 to assure a complete order.

2.2.2 Preinstallation Bench Check

A preinstallation bench check may be performed without connection to the transponder. The test equipment required is :

- a. 14/28 Vdc, 2 amp power supply
- b. Ohmmeter
- c. Pitot Static System Test Set

Prepare an AR850 mating connector (similar to the connector in section 2.4.5) as shown in Figure 2-1. Connect a clip lead to the wire on pin 6.

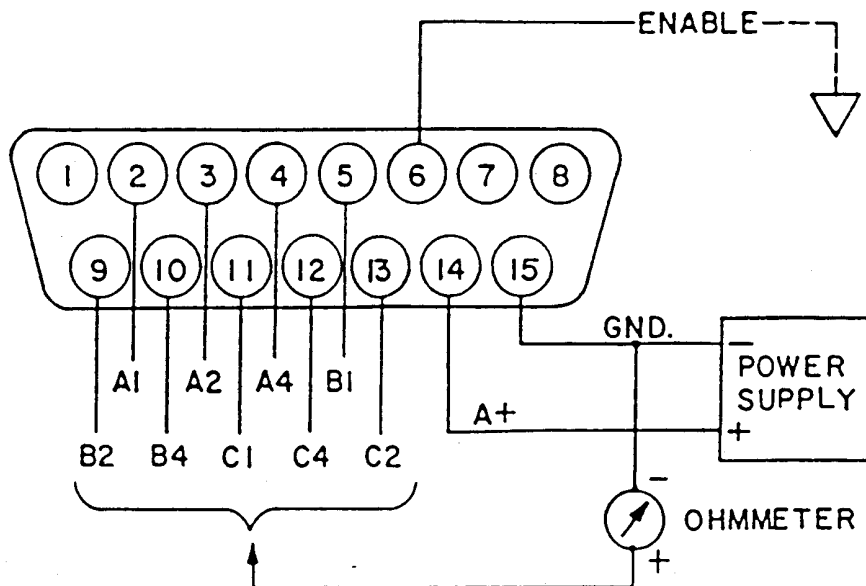

FIGURE 2-1 BENCH TEST SET UP

2.2.2 Continued

1. Connect the AR850 to the Pitot Static System Test Set. Apply 14V or 28V power and allow the system to stabilize for 5 minutes.
2. Check pins 3, 4, 5, 9, 10, 11, 12, 13 with the ohmmeter. They should all read a high resistance of 1 megohm or higher.
3. Clip pin 6 to ground.
4. Pump the AR850 to the following altitudes to check for operation of all the code lines. An active code line will read a low resistance of 200 ohms or lower.

USE EITHER LOWER OR HIGHER ALTITUDE TESTS

PIN NO.	2	3	4	5	9	10	11	12	13
CODE LINE	A1	A2	A4	B1	B2	B4	C1	C4	C2
ALTITUDE									
2400	HI	HI	HI	LO	HI	HI	LO	HI	LO
2800	HI	HI	LO	LO	HI	HI	HI	LO	HI
5500	HI	HI	LO	HI	LO	LO	HI	HI	LO
7500	HI	LO	LO	HI	HI	LO	HI	HI	LO
15500	LO	LO	HI	HI	HI	LO	HI	HI	LO
6500	HI	HI	LO	HI	HI	HI	HI	HI	LO
7300	HI	LO	LO	HI	HI	LO	LO	HI	HI
8600	HI	LO	LO	HI	LO	HI	HI	LO	LO
9500	HI	LO	LO	LO	LO	LO	HI	LO	LO
15500	LO	LO	HI	HI	HI	LO	HI	HI	LO

NOTE : LO denotes Low resistance  
 HI denotes High resistance

This completes the preinstallation bench check.

2.3 MECHANICAL INSTALLATION

The AR850 must be located within the internal structure of the aircraft. The location area to be non-pressurized and temperature controlled. It should be located away from the heater or fresh air vents that lead to very rapid changes of temperature. It may be mounted in any plane as well as inverted. The mounting base should be adequately secured in accordance with all applicable FARs. NO safety wire is necessary on the securing nut as a friction locking material is incorporated on the screw.

Refer to Figure 2-2 for the mechanical dimensions of the unit and tray. Figure 2-3A is a 1:1 Tray Template. Figure 2-3B is a 1:1 Case Template.

2.3.1 Static Connections

As shown here, a plastic static adapter is shipped installed on the AR850 to facilitate preinstallation bench checks and/or installation with 1/4 inch ID hosing to the aircraft's static system.

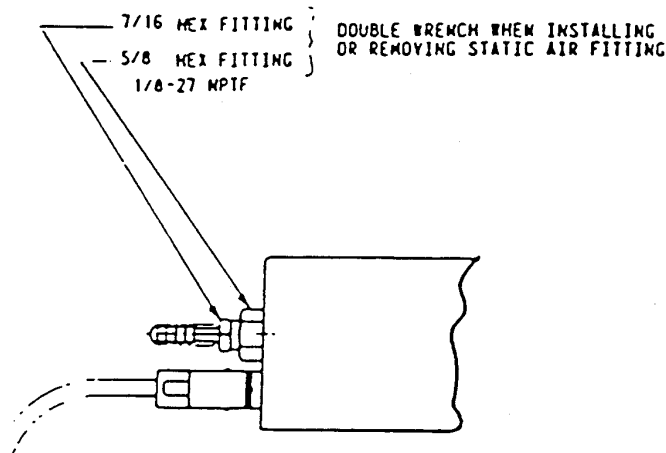

If another static connection is desired, the plastic adapter may be removed and replaced with any other acceptable 1/8-27 NPTF fitting.

The 5/8 inch hex fitting is permanently secured to the AR850 and should NOT be turned. Use a double wrench technique when installing or removing connections or adapters. Secure the static line adequately to the fitting.

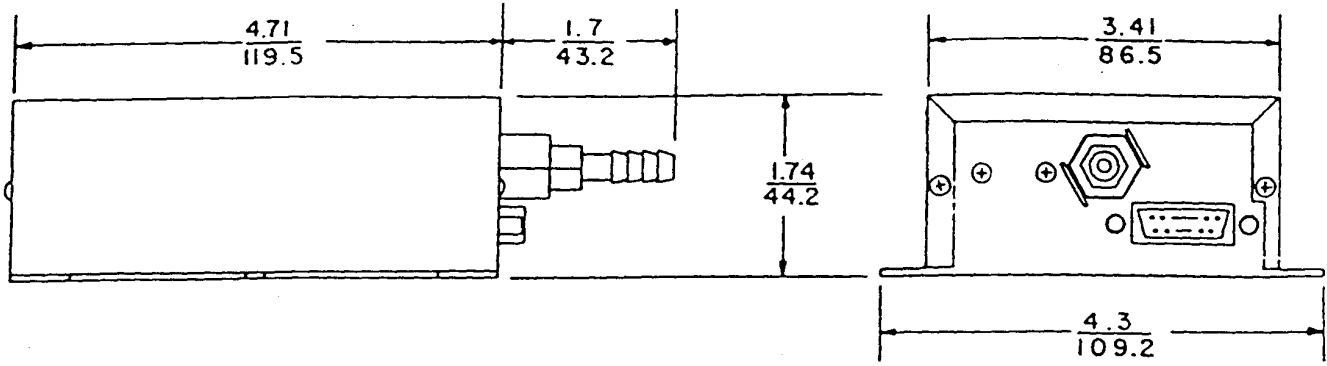

DIMENSIONS  $\frac{\text{IN.}}{\text{MM.}}$  (TYPICAL)

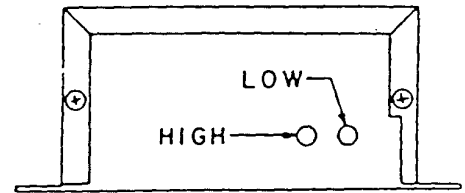

ALTITUDE ADJUSTMENT

AR850 UNIT DIMENSIONS

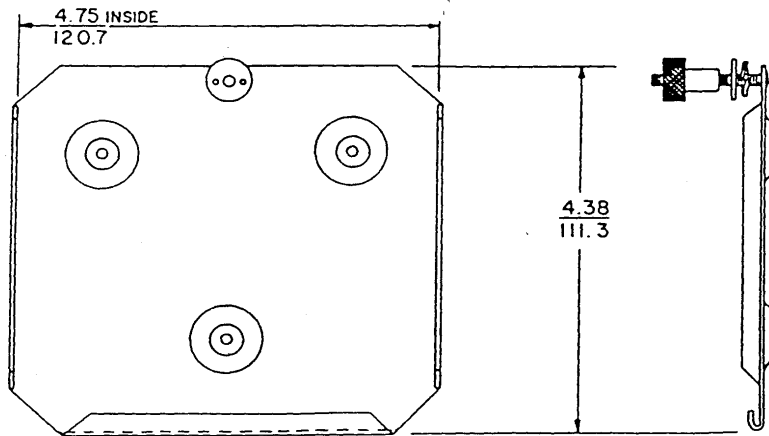

TRAY DIMENSIONS

FIGURE 2-2 AR850 MECHANICAL DIMENSIONS (not to scale)



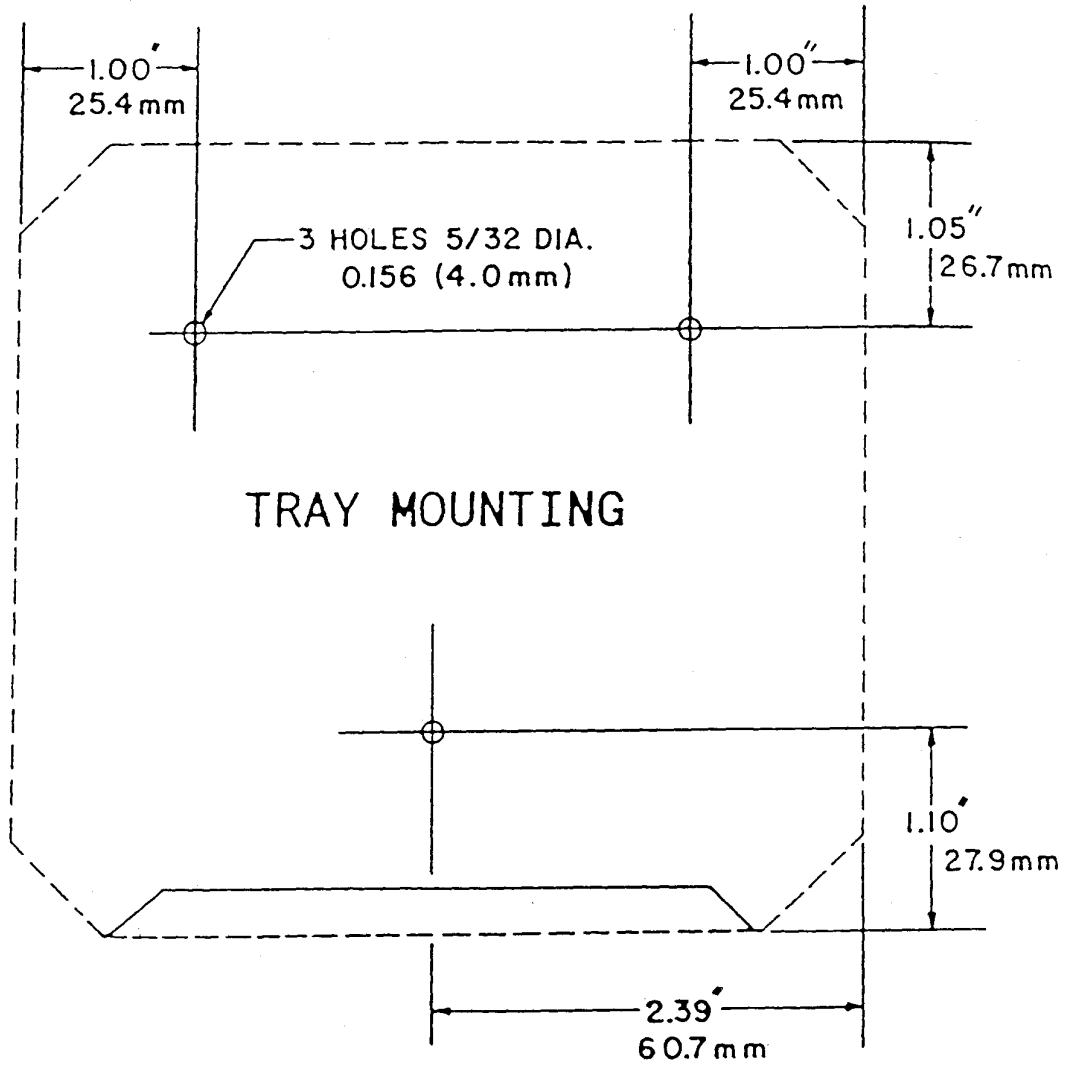

FIGURE 2-3A AR850 TRAY (not to scale)

THIS PAGE INTENTIONALLY LEFT BLANK.

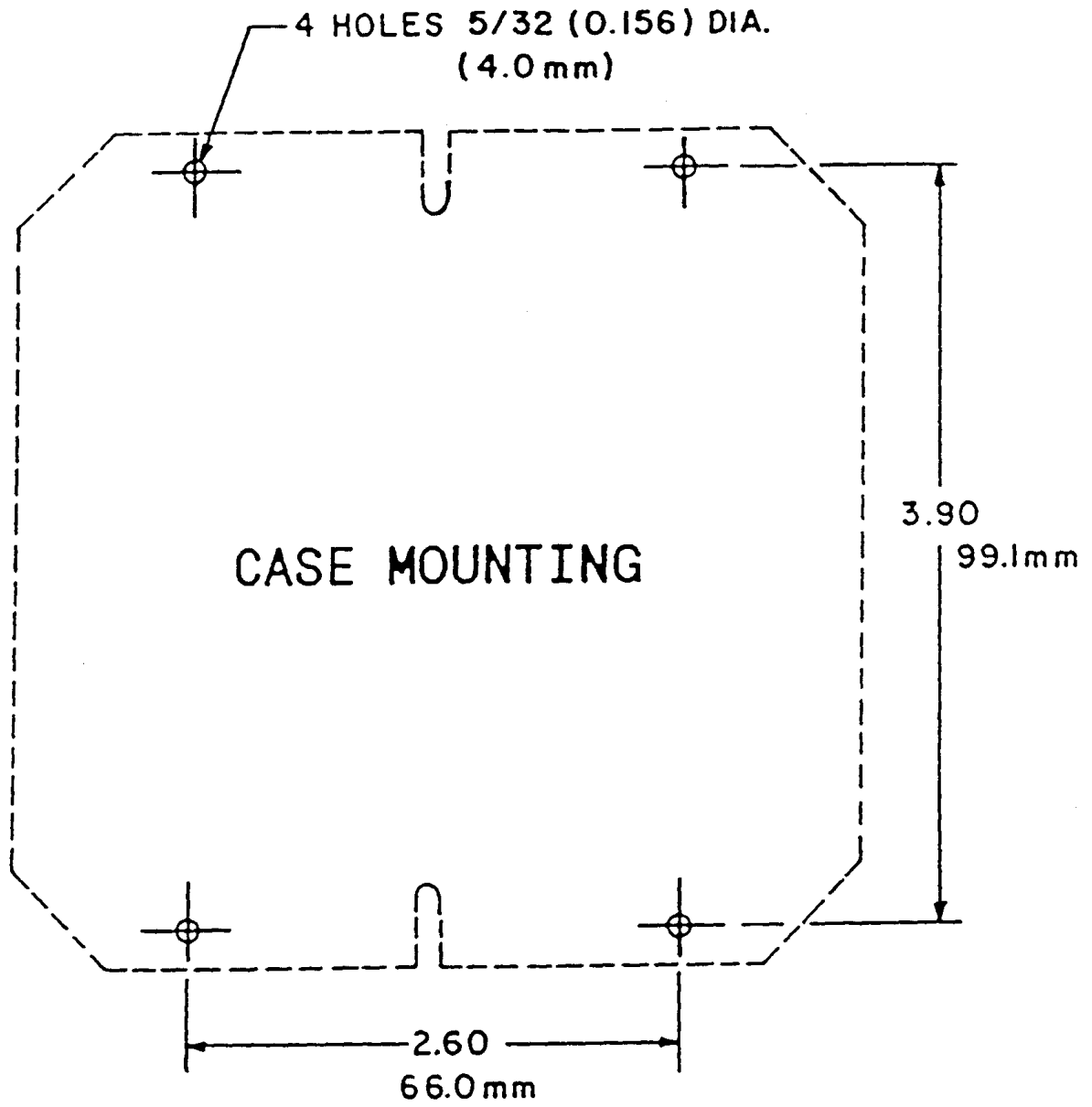

FIGURE 2.3B AR850 CASE MOUNTING (not to scale)

THIS PAGE INTENTIONALLY LEFT BLANK.

2.4 ELECTRICAL INSTALLATION

This section presents the required technical information necessary to plan and execute electrical installation of the AR850. Refer to Section 2.4.7 "Interconnect Wiring Diagrams" for installation of the AR850 to Narco and King transponders.

2.4.1 AR850 To Transponder Compatibility

The AR850 is compatible with all Narco TSO'd transponders as noted here:

1. AT155/AT150 : Directly compatible.  
No modifications required.
2. AT50/50A : Directly compatible when Narco Service Bulletin AT-50A-5 dated Feb. 19, 1975 is performed on the transponder.

2.4.2 AR850 ENABLE Requirements

Normally the transponder controls the enabling of the altitude reporter when in the altitude mode (Mode C). When the transponder is operating in its normal IDENT mode (Mode A), the altitude reporter is inhibited. Transponders may supply an ENABLE and/or STROBE output; those which supply only a STROBE output will not enable the AR850. The requirements are listed below.

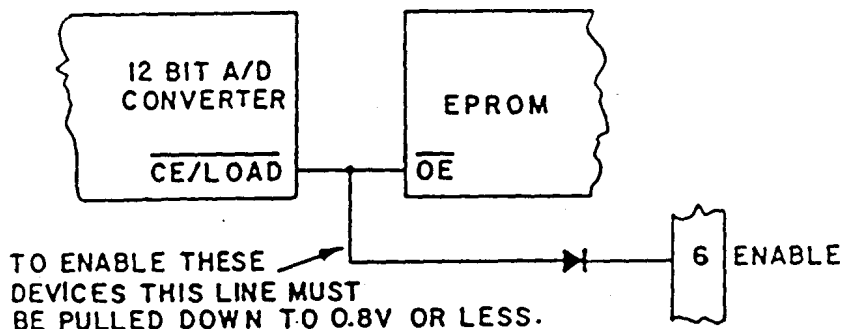

1. Activating the AR850 requires that a ground be applied to P101-6, the ENABLE input, only when the transponder is placed in the altitude mode. Normally the transponder would be the ground source. The installing agency should investigate the transponder ENABLE source and determine if the source is wired permanently to ground, switched to hard ground in the altitude mode, or grounded through an active device (transistor or IC) when in the altitude mode. If the ground source is an active device, when it is ON (active low), it must pull the transponder ENABLE output down to within 0.2V of ground or less. The diode in series with the AR850 ENABLE line has a junction voltage of 0.5V. This voltage must be added to the transponder's active device junction voltage, and the sum not to exceed 0.8V or else the EPROM and the 12 bit A/D Converter in the AR850 cannot be enabled.

2. If the transponder's internal ENABLE source is a permanent ground and not altitude mode controlled, the AR850 will be permanently enabled. When the altitude reporter is permanently enabled, the companion transponder must have additional internal circuitry designed to inhibit the transmission of altitude information when it is operating in other than the altitude mode. If the transponder cannot meet this requirement, the AR850 ENABLE input must be controlled by a panel mounted switch.

#### 2.4.3 Primary Power Requirement

- a) The AR850 accepts 11 to 32 Vdc for its primary power; therefore NO voltage converter is required for 28V aircraft electrical systems.
- b) The AR850 incorporates an "altitude sensor" heater which is energized when power is applied. Initial current draw is 1.4 amps for approximately 3 minutes, the time required to heat the sensor, after which the current drops to 0.35 amps average. The heater current is only required for warmup.
- c) Primary power is applied to the rear connector, J101, between pins 14 and 15 from the avionics bus. Do not use switched A+ output from the transponder. Connect a 2 amp resettable circuit breaker between the AR850 and the avionics bus. Pins 8, 14 are connected together internally.
- d) J101 pin 15 is airframe ground. Pins 1, 7, 15 are connected together internally.

#### 2.4.4 AR850 Altitude Code Line Characteristics

The AR850 altitude code line drivers comprise a high voltage, high sinking current, Darlington transistor array (Sprague ULN2003A). All drivers feature open collector outputs as shown below.

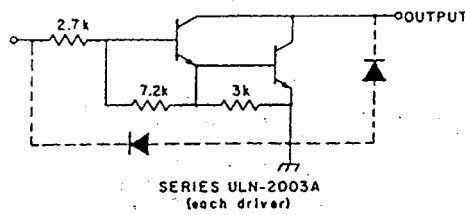

In the "OFF" state, the collector can accept from the transponder any pull up voltage up to 50 Vdc.

In the "ON" state, the collector to emitter saturation is 0.75V at 50 ma. or 1.1V at 100 ma. sinking currents.

2.4.5 Interconnect Cable Fabrication

An interconnecting cable must be fabricated by the installing agency. Figure 2-4 shows the assembly of the AR850 connector P101.

- 1) Strip wire as shown in fig. 2-4. Maximum wire size is # 20 AWG.
- 2) Tin exposed lead. Be sure no individual wire strands are free!
- 3) Insert lead into socket until lead is visible at inspection port.
- 4) Heat socket and apply solder as shown until solder wicks into socket cavity and becomes visible through inspection port.
- 5) Insert socket into connector housing until a "click" is heard or felt: exert a slight pull on the wire to assure socket seating.
- 6) Final assembly :
  - a) Put hood in place around connector housing and cable.
  - b) Position cable clamp and hole filler.
  - c) Close the hood's lid and tighten 3 phillips screws.
  - d) Attach P101 to the AR850 with 2 connector hold-down screws.

Figure 2-5 shows the pin assignments to P101. Interconnect wiring diagrams are provided in Section 2.4.7 APPENDIX.

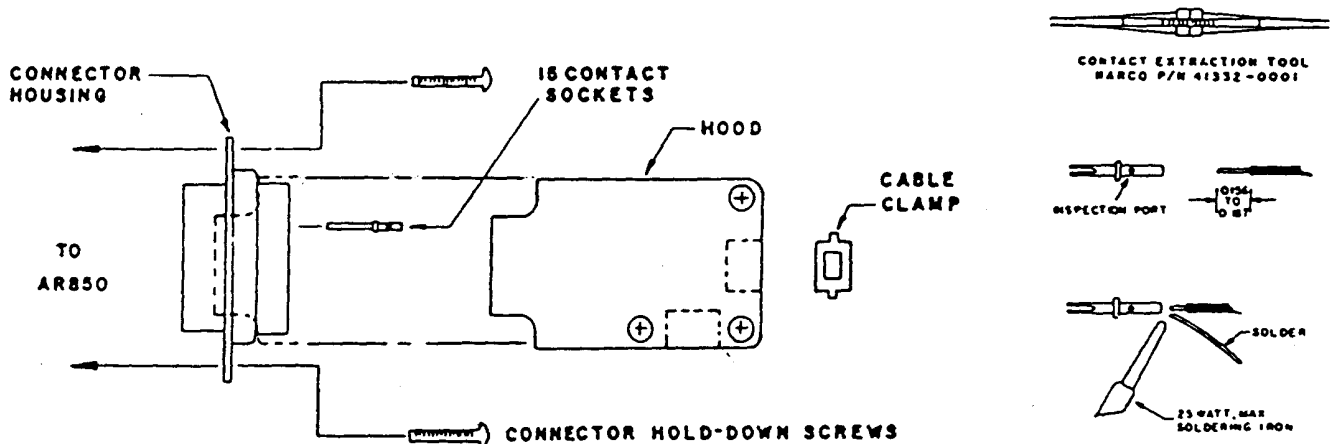
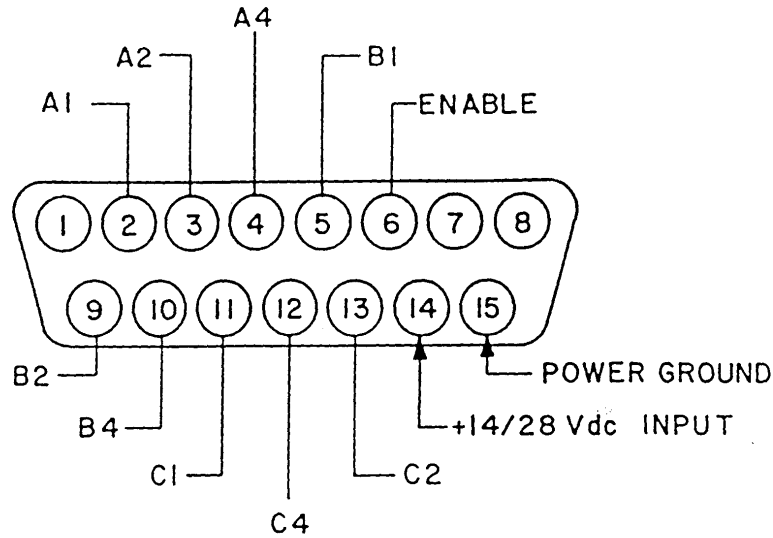

FIGURE 2-4 P101 ASSEMBLY



**REAR VIEW**

- NOTES : 1. PINS 1, 7, 15 CONNECTED TOGETHER INTERNALLY.  
 2. PINS 8, 14 CONNECTED TOGETHER INTERNALLY.

FIGURE 2-5 P101 PIN ASSIGNMENTS

2.4.6 Correspondence Tests

A data correspondence check between automatically reported pressure altitude and the pilot's altitude (aircraft altimeter) reference is required.

The AR850 Altitude Reporter shall correspond to the aircraft altimeter within  $\pm 125$  feet (38.1 meters) when the pressure datum is set for 29.921 inches of mercury absolute (1013.25 millibars).

2.4.6.1 Test Equipment Requirements

Any test equipment capable of "reading " the code generated by the AR850 and/or replies transmitted by the transponder is acceptable.

The most convenient equipment is the self-contained "ramp check" type available from several manufacturers which "reads" the altitude in the ABCD code and/or feet.

The pneumatic equipment must be of high quality and precision and be capable of exercising the AR850 and aircraft altimeter over the range of -500 to +30,700 feet. The equipment must be capable of holding an altitude long enough to obtain accurate data to confirm correspondence.

2.4.6.2 Test Procedure

1. Allow AR850 to warm up 15 minutes before beginning the test.



2. Attach the vacuum/pressure pump system and set up the altitude reporter/transponder test equipment.
3. Adjust the altimeter barometric setting to 29.92 inches of mercury so the altimeter hands correspond with the altitude reporter's data output.
4. Pump the altimeter and altitude reporter or static system between -500 and +7000 ft. Verify at several test points (chosen by checking technician), after AR850 data transition, that the altimeter reads within  $\pm 125$  ft. of the reported altitude transmitted by the transponder. If the altimeter correspondence exceeds 125 ft., altimeter calibration should be suspected.

The zero foot calibration may be adjusted as follows:

**NOTE : Low and high altitude adjustments are accessible thru marked holes in the dust cover.**

Pump the system such that the altimeter reads -50 feet. Adjust the low ALT pot. until the reported code flickers between -100 and 0 feet (codes 0660 & 0620). This adjustment affects the calibration at all altitudes and must be done first.



5. Pump the system between 7000 and 30,700 ft. Verify at several chosen test altitudes, after transition, the altimeter reads within 125 feet of the reported altitude. If the correspondence is acceptable, go to steps 9 and 10; if not, go to step 6.
6. Adjustment of correspondence above +7000 feet.
  - a. Pump the system to make the altimeter read 30,650 ft.
  - b. Adjust the High ALT to make the transponder read alternately 30,600 to 30,700 ft.
  - c. Check Correspondence at 10,050, 15,050 and 19,950 ft.
7. Recheck the -50 ft. calibration and adjust if necessary.
8. Repeat step 6. If correspondence is not acceptable, altimeter calibration should be suspected.
9. Turn transponder to Mode A only. Ensure there are only framing pulses (F1 and F2) present.
10. Conduct an aircraft static leak test at the conclusion of correspondence tests.
11. Placard Placement and Alteration
  - a) The placard should be prominently displayed on the aircraft instrument panel.
  - b) If the tested altitude is less than 30,700 feet, the placard should be altered by inserting the altitude tested after "OPERABLE TO".

2.4.7 Interconnect Wiring Diagrams

This section provides interconnect wiring instructions for connecting the AR850 to Narco and King transponders.

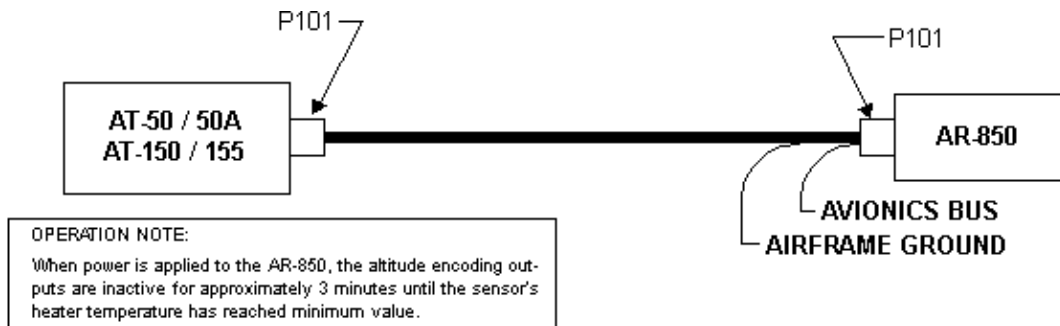
2.4.7.1 AR850 to AT155/AT150/AT50/50A Installation



	2 AMPS			
		11 - 32 VDC AVIONICS BUS		P101-14
		AIRFRAME GROUND		P101-15
P101-5	- - - -	ENABLE	- - - - -	P101-6
P101-7	- - - -	A1	- - - - -	P101-2
P101-12	- - -	B1	- - - - -	P101-5
P101-14	- - -	C1	- - - - -	P101-11
P101-6	- - - -	A2	- - - - -	P101-3
P101-10	- - -	B2	- - - - -	P101-9
P101-11	- - -	C2	- - - - -	P101-13
P101-8	- - - -	A4	- - - - -	P101-4
P101-9	- - - -	B4	- - - - -	P101-10
P101-13	- - -	C4	- - - - -	P101-12

NOTE: AT50/50A Transponders must comply with Narco service Bulletin AT-50A-5 dated Feb. 19, 1975.

FIGURE 2-6 AR850 TO AT155, AT150 OR AT50/50A INTERCONNECTIONS

2.4.7.2 AR850 to KING KT 76/78

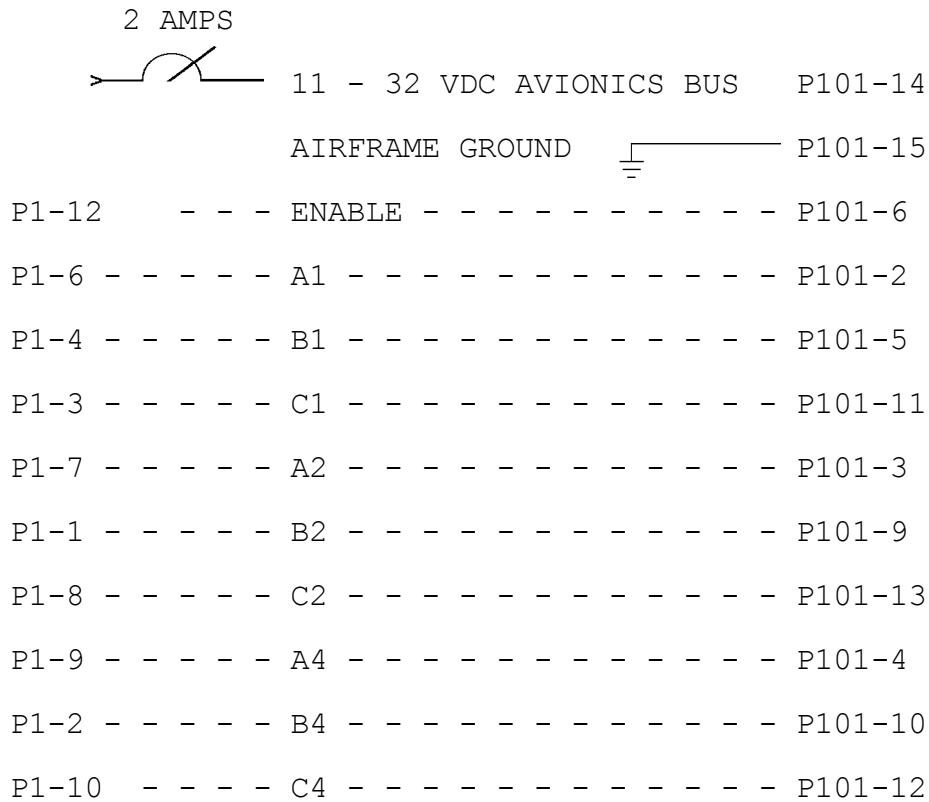
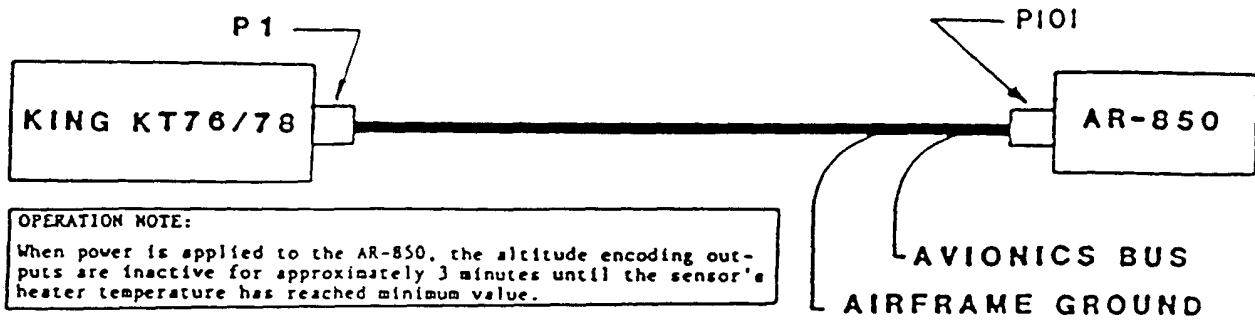

**CAUTION - This drawing is for reference only. Consult the manufacturer's Transponder manual to confirm proper pin connections.**

FIGURE 2-7 AR850 TO KT 76/78 INTERCONNECTIONS

2.4.7.3 AR850 to KING KT 76A/78A/79

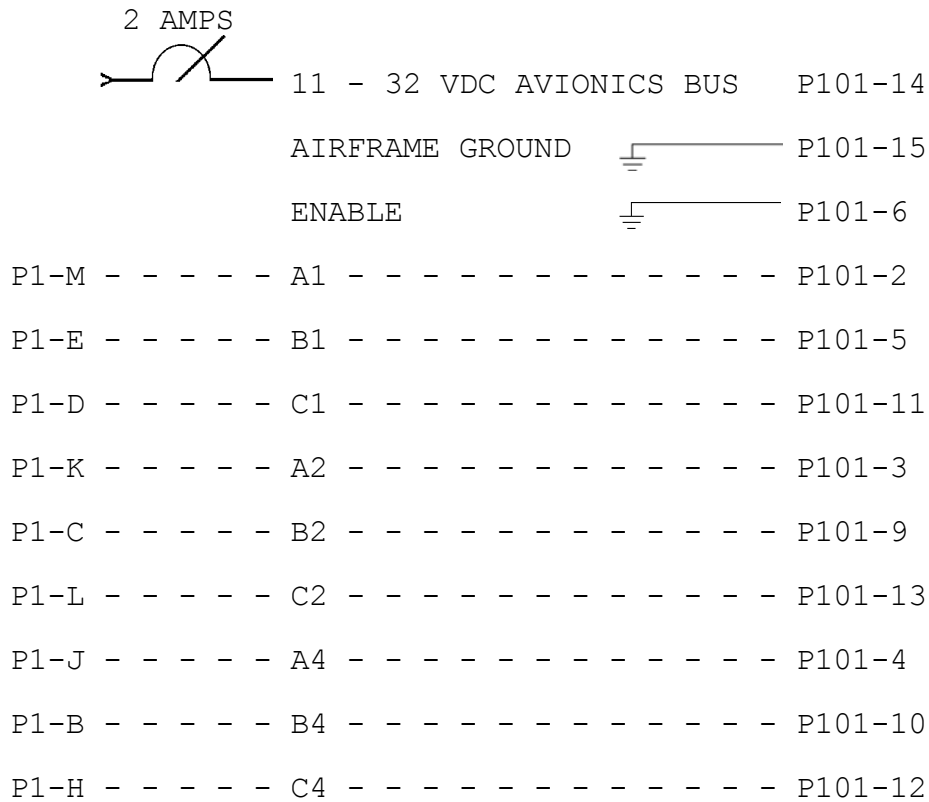
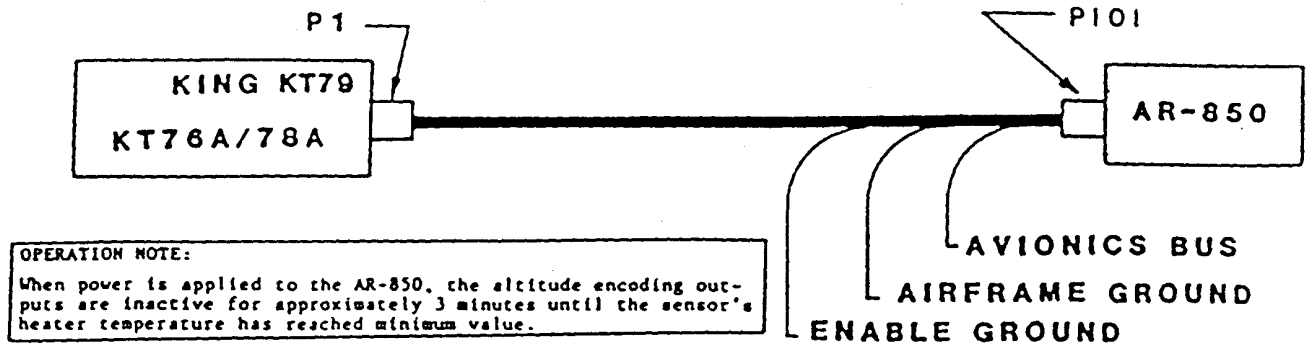

**CAUTION - This drawing is for reference only. Consult the manufacturer's Transponder manual to confirm proper pin connections.**

FIGURE 2-8 AR850 TO KT 76A/78A/79 INTERCONNECTIONS

2.5 POST INSTALLATION TESTS

To certify the installation, FAA Form 337 must be completed. In addition, weight and balance or any operating limitations must be entered into the aircraft logbook. Refer to the current Federal Aviation Regulations for any additional requirements.

Weight :                                   Unit - 0.7 lbs. (0.318 kg.)  
  Tray - 0.090 lbs. (0.041 kg.)

Power Requirements : 11 to 32 Vdc at 1.4 amps maximum during the first 3 minutes of operation. 0.35 amps average after 3 minutes of operation.

2.5.1 Preflight Tests

A preflight test should be performed using test equipment described in section 2.4.6.1 of this manual. The test shall be performed in accordance to F.A.R. 91.411 or other applicable air regulation.

THIS PAGE INTENTIONALLY LEFT BLANK

### 3.1 GENERAL

The purpose of the AR850 Altitude Reporter is to establish a digital code which is a direct function of aircraft altitude. Since the AR850 is TSO'd, the parallel digital code is that set forth in the International (ICAO) Standard code for SSR Pressure Altitude Transmission.

### 3.2 OPERATION

The AR850 is a remote mounted unit that is fully automatic in operation. The companion transponder normally controls the operation of the AR850 by automatically enabling or inhibiting its operation. It is in operation (enabled) any time the transponder is set to the altitude (Mode C) mode of operation. The information is inhibited (removed) any time the altitude mode is turned OFF or to IDENT (MODE A).

When the transponder has internal circuitry designed to inhibit the transmission of altitude information independent of the AR850, then the AR850 may be permanently "enabled".

OPERATION NOTE:

When power is applied to the AR850, the altitude encoding outputs are inactive for approximately 3 minutes until the sensor's heater temperature has reached minimum value.

THIS PAGE INTENTIONALLY LEFT BLANK



## HISTORY FILE

RELEASED: 06/01

07/2003

Page 1-I Added AT155 to line 2.4..7.1 and 2-6

Page 2-9 Added AT155 to 2.4.1 1.

Page 2-14 Added AT155 to line 2.4.7.1  
Added 155 to graphic  
Added breaker symbol under 2 AMPS  
Added ground symbol next to P101-15  
Added AT155 FIGURE 2-6 line

Page 2-15 Added breaker symbol under 2 AMPS  
Added ground symbol next to P101-15

Page 2-16 Added breaker symbol under 2 AMPS  
Added ground symbol next to P101-15  
Added ground symbol next to P101-6

THIS PAGE INTENTIONALLY LEFT BLANK

**ENVIRONMENTAL QUALIFICATION FORM**

NOTE: THIS FORM TO BE FILED WITH THE OWNER'S AVIONICS RECORDS.

NOMENCLATURE: AUTOMATIC PRESSURE ALTITUDE CODE GENERATING EQUIPMENT

MODEL: AR-850 TSO NUMBER: C88a

MANUFACTURER: NARCO AVIONICS, INC.

ADDRESS: 270 COMMERCE DRIVE

FORT WASHINGTON, PA 19034

CONDITIONS	SECTION /2/ PARAGRAPH #	DESCRIPTION OF CONDUCTED TESTS
TEMPERATURE AND ALTITUDE	4.0 Rev. 1	EQUIPMENT TESTED TO CATEGORIES "B1"
LOW TEMPERATURE	4.5.1	-20°C (-4°F)
HIGH TEMPERATURE	4.5.3	+55°C (+131°F)
ALTITUDE	4.6.1	
DECOMPRESSION	4.6.2	+9357 Meters (30,700 ft.)
OVERPRESSURE	4.6.3	
TEMPERATURE VARIATION	5.0	EQUIPMENT TESTED TO CATEGORY "B"
HUMIDITY	6.0	EQUIPMENT TESTED TO CATEGORY "A"
SHOCK	7.0	EQUIPMENT TESTED PER DO-160B
OPERATIONAL	7.2	MEETS REQUIREMENTS OF DO-160B
CRASH SAFETY	7.3	NOT APPLICABLE
VIBRATION	8.0	EQUIPMENT TESTED WITHOUT SHOCK MOUNTS TO CATEGORY "NMO"
EXPLOSION	9.0	EQUIPMENT IDENTIFIED AS 'X', NOT TESTED FOR THIS FEATURE
WATERPROOFNESS	10.0	EQUIPMENT IDENTIFIED AS 'X', NOT TESTED FOR THIS FEATURE
FLUIDS SUSCEPTIBILITY	11.0	EQUIPMENT IDENTIFIED AS 'X', NOT TESTED FOR THIS FEATURE

SAND AND DUST	12.0	EQUIPMENT IDENTIFIED AS 'X' NOT TESTED FOR THIS FEATURE
FUNGUS	13.0	EQUIPMENT IDENTIFIED AS 'X' NOT TESTED FOR THIS FEATURE
SALT SPRAY	14.0	EQUIPMENT IDENTIFIED AS 'X' NOT TESTED FOR THIS FEATURE
MAGNETIC EFFECT	15.0	EQUIPMENT TESTED TO CATEGORY "Z"
POWER INPUT	16.0	EQUIPMENT TESTED TO CATEGORY "B"
VOLTAGE SPIKE CONDUCTED	17.0	EQUIPMENT TESTED TO CATEGORY "B"
AUDIO FREQUENCY CONDUCTED SUSCEPTIBILITY	18.0	EQUIPMENT TESTED TO CATEGORY "B"
ADUCED SIGNAL SUSCEPTIBILITY	19.0	EQUIPMENT TESTED TO CATEGORY "B"
RADIO FREQUENCY SUSCEPTIBILITY	20.0	EQUIPMENT TESTED TO CATEGORY "B"
RADIO FREQUENCY EMISSION	21.0	EQUIPMENT TESTED TO CATEGORY "B"
OTHER TESTS		FIRE RESISTANCE TESTS WERE CONDUCTED IN ACCORDANCE WITH FEDERAL AVIATION REGULATION, PART 25, APPENDIX F