



DO IT YOURSELF AUDIO ISOLATION AMPLIFIER



TYPICAL MONOPHONIC
AND STEREO SYSTEMS
SHOWN

REVISION -J- 09 SEP 06
Rev L 09/25/09

NOTE:

1. OPERATING VOLTAGE: 10.5 TO 30 VDC
2. OPERATING CURRENT: 0.05A MAX
3. MONOPHONIC INPUTS MIXED TO BOTH OUTPUT CHANNELS: 3
4. STEREO INPUTS: 1 SET
5. OUTPUT POWER: 100 MW PER CHANNEL

6. RESISTORS RI03 THROUGH RI07 ARE SELECTED TO EQUALIZE VOLUME LEVELS BETWEEN AUDIO SOURCES. START WITH 150 OHM RESISTORS IN ALL 5 LOCATIONS (DIGIKEY I50EBK-ND). FOR SOURCES WITH ADJUSTABLE VOLUME CONTROLS, THE GOAL IS TO ACHIEVE NORMAL LISTENING LEVELS WITH SOURCE CONTROL AT 1/3 TO 1/2 OF FULL TRAVEL. ADJUST RESISTOR VALUES UPWARD TO DECREASE VOLUME. THEN ADJUST RESISTORS FOR FIXED SOURCES (WARNING TONES, ETC) TO ACHIEVE LEVEL COMPATABLE WITH NORMAL LISTENING LEVELS FOR OTHER SOURCES.

1/4W RESISTORS FOR RI03 THRU RI07 WILL "PLUG IN" TO A MACHINED PIN I.C. SOCKET AS SHOWN IN PHOTOGRAPH. ONE NEEDS TO SHORTEN A STOCK I4-PIN (7 SLOTS) TO A 10-PIN (5 SLOT) SOCKET ON A BELT SANDER BEFORE INSTALLATION ON ECB.

7. EVERY AUDIO SYSTEM WOULD BENEFIT FROM A HEADSET JACK WIRED TO GIVE YOU ACCESS TO THE COMM RADIO EVEN IF THE AUDIO AMPLIFIER ROLLS BELLY UP OR BECOMES UNPOWERED. WIRE AS SHOWN HERE. DO THE SAME THING FOR A MICROPHONE JACK UNLESS YOUR INTERCOM SYSTEM HAS A POWER-DOWN BYPASS FEATURE BUILT IN.
8. SOME ENTERTAINMENT AUDIO SOURCES DO NOT HAVE LOW LEVEL AUDIO OUTPUT CONNECTIONS. IF YOU MUST USE SPEAKER OUTPUT WIRES, YOU MIGHT NEED TO PROVIDE A "DUMMY LOAD" RESISTOR TO MAKE THE SOURCE BELIEVE IT IS DRIVING A SPEAKER. A 10-OHM, 1-WATT RESISTOR WILL USUALLY SUFFICE. SPACES HAVE BE PROVIDED ON THE BOARD TO INSTALL THESE RESISTORS. IF IN DOUBT, TRY RUNNING THE SYSTEM WITHOUT LOAD RESISTORS. LISTEN FOR DISTORTION AT LOW AUDIO LEVELS (VOICE PROGRAM MATERIAL IS BEST FOR THIS). IF NO DISTORTION NOTED, NO LOAD RESISTORS NEEDED.
9. SIGTRONICS HARNESS IS SUPPLIED WITH WIRES COLOR CODED AS SHOWN AT WIRES MARKED (*). IF IT WERE MY AIRPLANE, I'D REPLACE THE COLOR CODED WIRES WITH SHIELDED WIRES AS SHOWN. TERMINATE SHIELDS ONLY AS SHOWN.

10. SHIELDS FOR THESE WIRES CONNECTED THIS END ONLY.
11. GROUND SYMBOL ON SCHEMATIC DENOTES COMMON GROUND FOR THE ASSEMBLY. THIS GROUND SHOULD ISOLATED FROM THE CHASSIS GROUND.
12. WWW.DIGIKEY.COM CAN SUPPLY ALL PARTS.
13. THE AMPLIFIER AS SHOWN PROVIDES APPROXIMATELY UNITY GAIN.
14. CONNECTOR PIN NUMBER VARIATIONS: CONNECTOR PIN NUMBERS IN THIS DOCUMENT ASSUMES A 15-PIN MALE SOLDERED TO THE COMPONENT SIDE OF THE BOARD. D-SUB CONNECTORS ARE SYMETRICAL SO THAT THEY CAN BE INSTALLED ON EITHER SIDE OF THE BOARD WITH A REVERSED NUMBER PATTERN. IF YOU USE OUR ECB AND ASSEMBLE IT ON SIDE OPPOSITE ILLUSTRATIONS (CONNECTOR ON SAME SIDE AS COMPONENTS), THE PINOUTS WILL BE DIFFERENT THAN WHAT IS CALLED OUT IN THIS DRAWING PACKAGE.

FUNCTION NAME	PIN # FOR COMP SIDE CONNECTOR	PIN # FOR SOLDER SIDE CONNECTOR
+14V IN	1	8
L AUDIO OUT	2	7
R AUDIO OUT	3	6
L STEREO IN	4	5
A AUDIO IN	5	4
B AUDIO IN	6	3
C AUDIO IN	7	2
R STEREO IN	8	1

THIS IS THE PINOUT FOR ASSEMBLY AS-ILLUSTRATED THAT ALSO MATCHES WHAT'S SHOWN IN WIRING DIAGRAMS.

ALL OF THE PINS IN THE SHORT ROW (9 THRU 15) ARE GROUND IRRESPECTIVE OF CONNECTOR ORIENTATION.

15. AN ETCHED CIRCUIT BOARD FOR DIY ASSEMBLY IS AVAILABLE FROM AEROELECTRIC CONNECTION ORDER PART NUMBER AEC9009-301-2A

NOTE

SPECIFIC DIGIKEY CATALOG NUMBERS CALLED OUT MAY CHANGE. DIGIKY IS A DYNAMIC SUPPLIER. THEY CONSTANTLY UPDATE THEIR INVENTORY WITH THE LATEST INTERCHANGEABLE PARTS. IF YOU CAN'T FIND A PART THAT IS CALLED OUT TO THE RIGHT, YOU MAY NEED TO LOOK THROUGH THE CATALOG AND FIND THE UPDATED RECOMMENDATION. CHECK WITH US ON THE AEROELECTRIC-LIST IF YOU HAVE QUESTIONS ON PARTS PROCUREMENT.

		1	1	130	PI20BACT	120 OHM, 1/4W, 5% CF	DIGIKEY
		1	1	129	P750BACT	750 OHM, 1/4W, 5% CF	DIGIKEY
		1	1	128	LM317TFS	V-REG, TO220-3	DIGIKEY
		1	1	127	399-1429	1.0UF/35V DIP TANT	DIGIKEY
				126	S/A 125		
		1	2	125	PI00BACT	100 OHM, 5%, 1/4W CF	DIGIKEY
				124	S/A 122		
				123	S/A 122		
		2	3	122	399-1395	47UF, 10V DIP TANT	DIGIKEY
				121	S/A 120		
		1	2	120	399-2127	0.1UF/50V MONO CERAMIC	DIGIKEY
				119	S/A 118		
		1	2	118	PI2BACT	12 OHM, 5%, 1/4W CF	DIGIKEY
				117	S/A 109		
				116	S/A 109		
				115	S/A 114		
		1	2	114	LM386N-1	AUDIO AMP, 8-DIP	DIGIKEY
				113	S/A 109		
				112	S/A 109		
				111	S/A 109		
				110	S/A 109		
		6	7	109	399-1403	10UF/16V DIP TANT	DIGIKEY
				108	S/A 101		
				107			
				106			
				105			
				104			
				103			
				102	S/A 101		
		2	3	101	10EBK	10 OHM, 1/8W, 5% CF	DIGIKEY
		1	1	100	4215M	CONNECTOR, D15M ECB	DIGIKEY
				99	S/A 98		
		2	2	98	PI0W-IBK	10 OHM, 1W, 5% CF (NOTE 8)	DIGIKEY
		1	1	12	COMM STOCK	ALUM PLATE 2.1 X 3.8 X 0.050	
		1	1	11	HM605	2.7 X 2.2 X 1.6 PROJECT BOX	DIGIKEY
		1	1	10	A23423	JACKSCREW KIT	DIGIKEY
				9	NOT USED		
		1	1	8	ED60001	IC SOCKET, 14-DIP	DIGIKEY
				7	S/A 6		
		1	2	6	A24794	IC SOCKET, 8-DIP	DIGIKEY
		4	4	5	1891K	4-40 X .25" X .186 SPACER	DIGIKEY
		3	3	4	COMM STOCK	4-40 X.19 HEX NUT (SMALL PATTERN)	
		5	5	3	H342	4-40 X .25 PHP STEEL	DIGIKEY
		2	2	2	COMM STOCK	#4 FLAT WASHER	
		1	1	1	9009-301-2A	ECB	AEC
					9009-100-2	ECB ASSY - MONO ISO AMP	DIY FAB
					9009-100-1	ECB ASSY - STEREO ISO AMP	DIY FAB
		/-2	/-1	ITEM #	P/N	DESCRIPTION	SOURCE
		QTY/ASSY					

(DON'T FORGET TO ORDER THESE! - SEE NOTE 6)

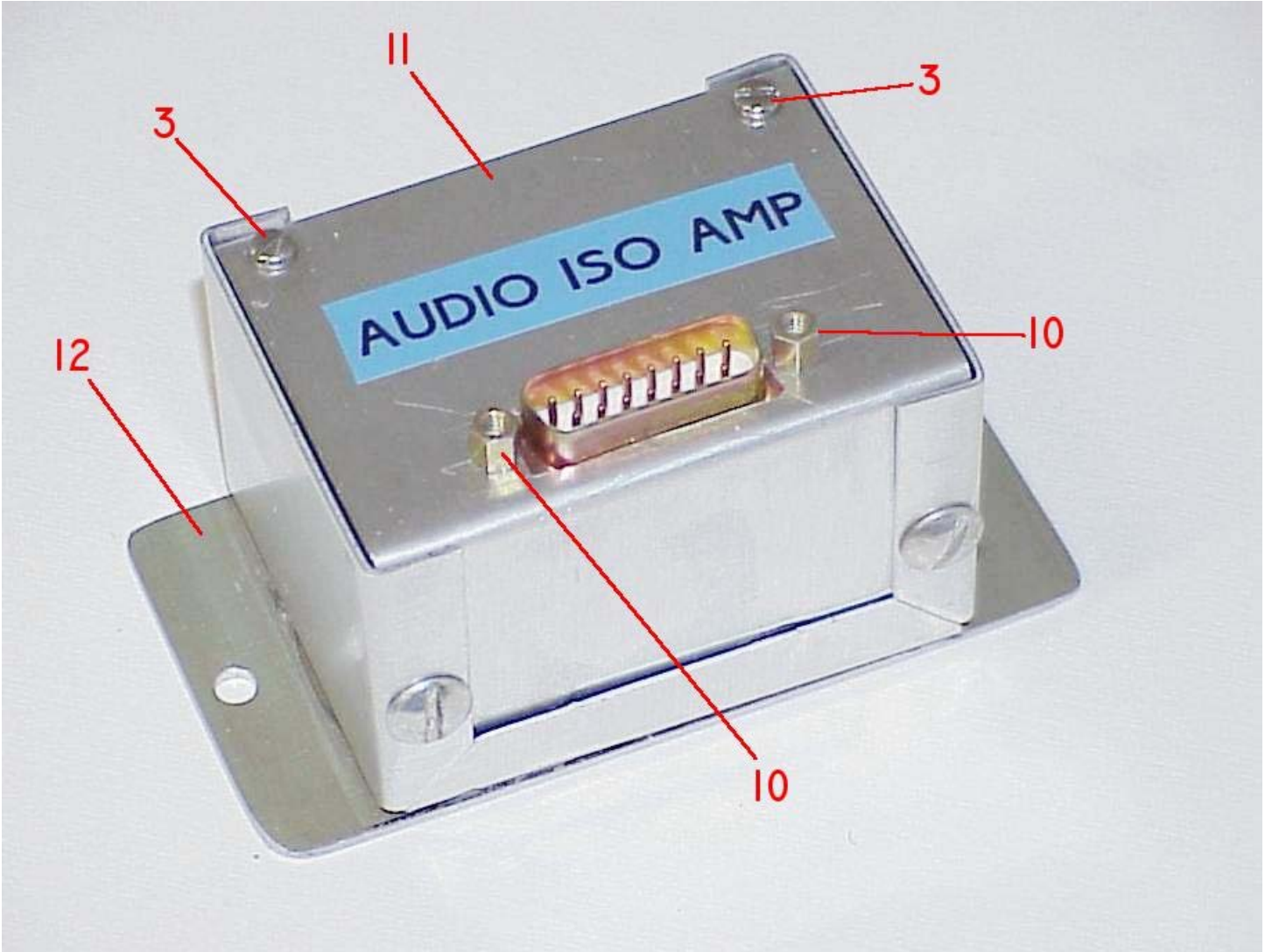

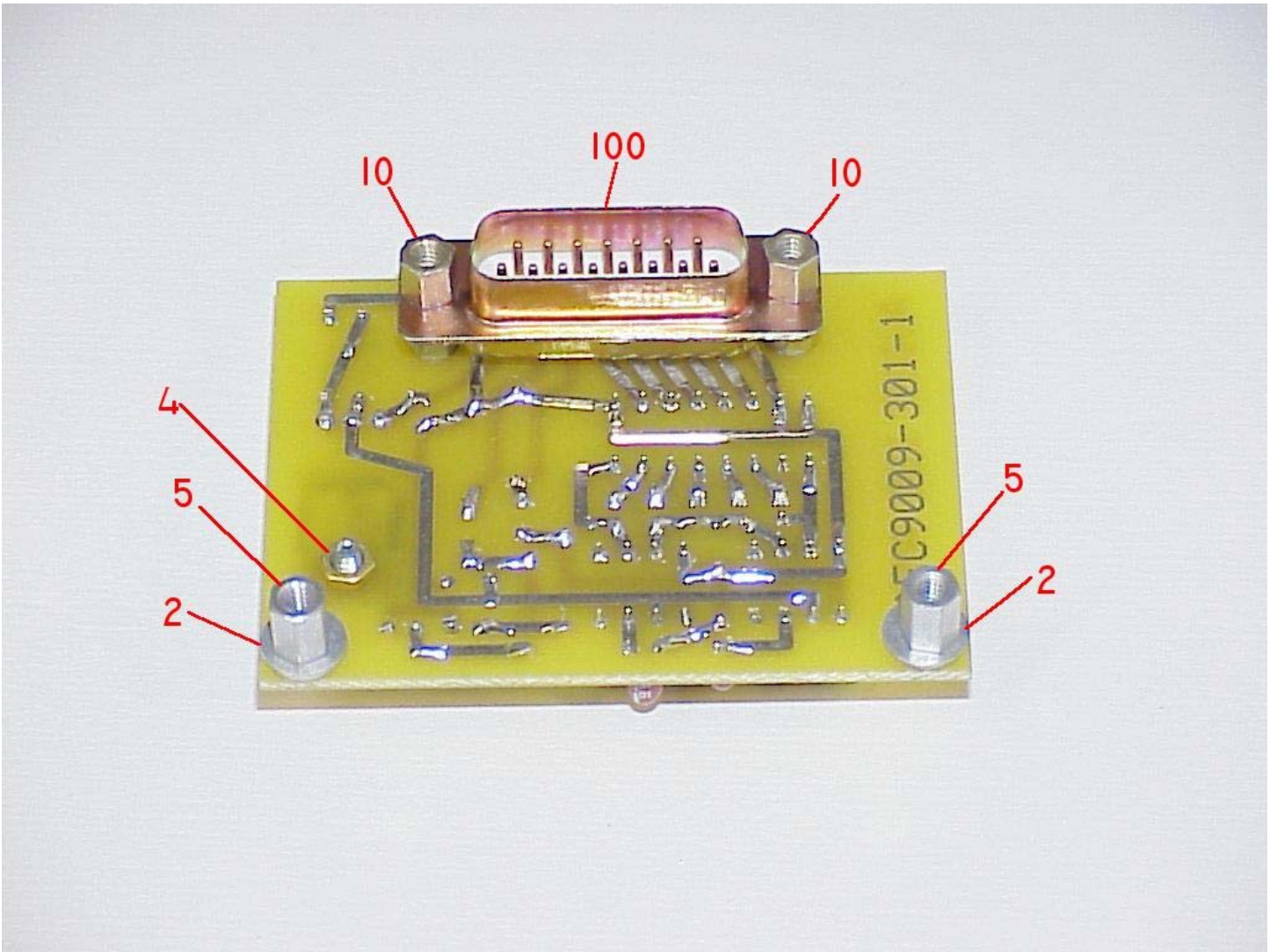

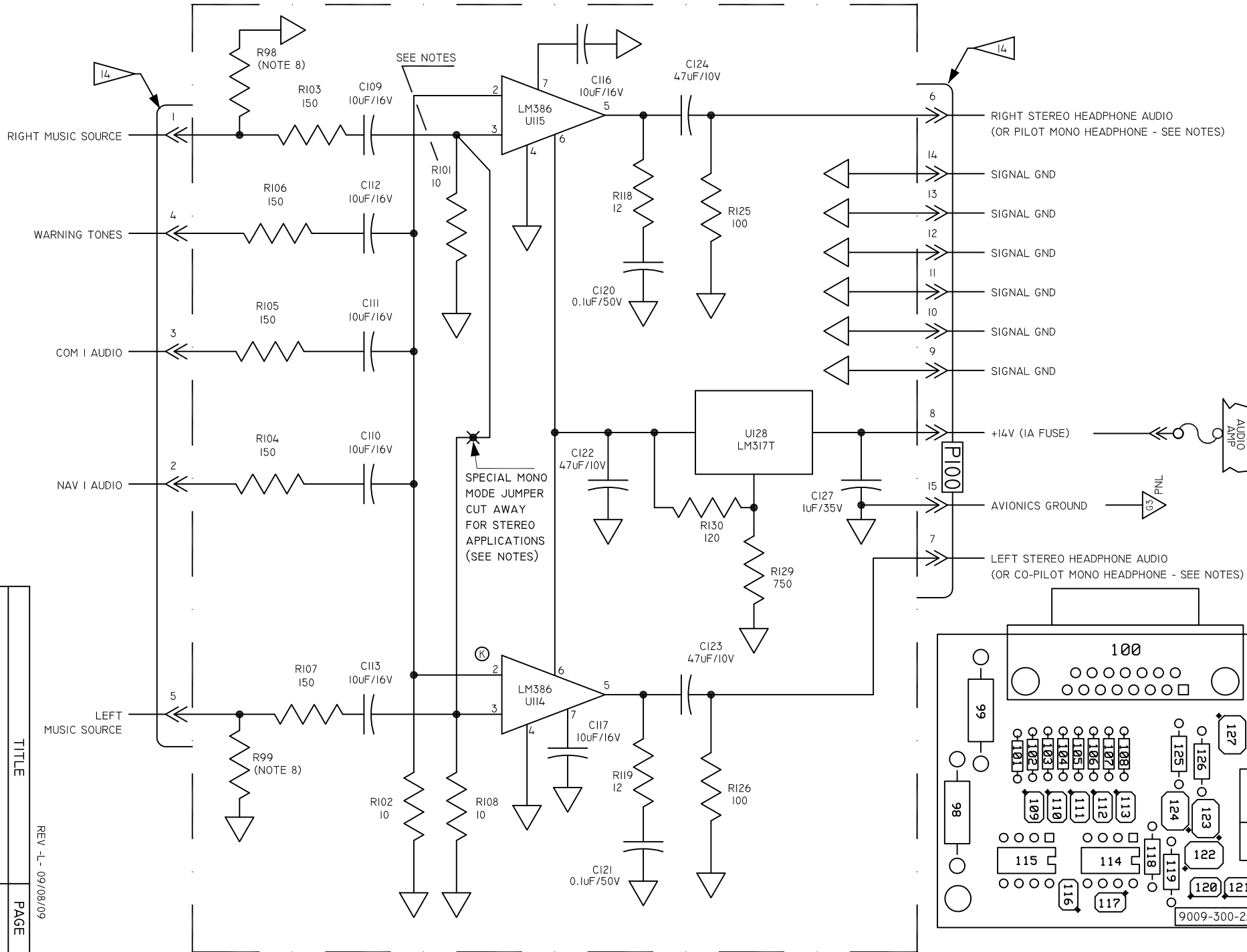

SCHEMATIC - STEREO

TITLE

PAGE

1.7

REV -L- 09/08/09

SPECIAL MONO-MODE JUMPER
SEE NOTES

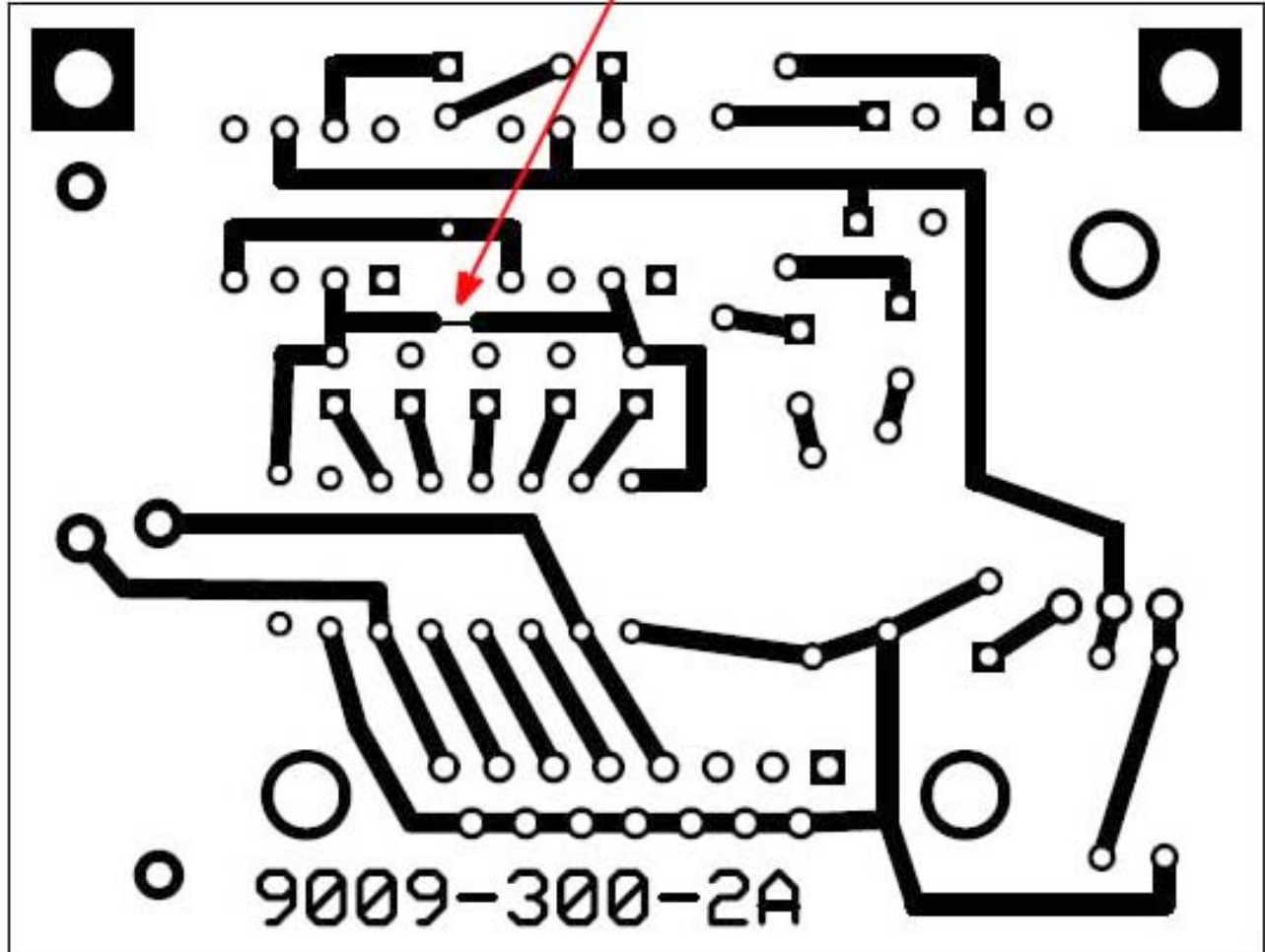

FOR STEREO OPERATION, THE JUMPER SHOWN ABOVE IS CUT AWAY WITH AN X-ACTO KNIFE. FOR PURELY MONOPHONIC OPS, THE INSTALLER MAY ASSEMBLE A STEREO AMPLIFIER EXCEPT DELETE RESISTOR R101 AND LEAVE THE JUMPER INTACT. ALL INPUTS BECOME MONOPHONIC INPUTS FROM VARIOUS SOURCES. THE PILOT AND COPILOT HEADPHONES MAY NOW BE DRIVEN BY ITS OWN AUDIO AMPLIFIER ON RIGHT AND LEFT CHANNELS OF THE ISO-AMP. THIS OPTION PREVENTS A SHORT ON ONE HEADSET LINE FROM DISABLING BOTH PAIRS OF HEADSETS.

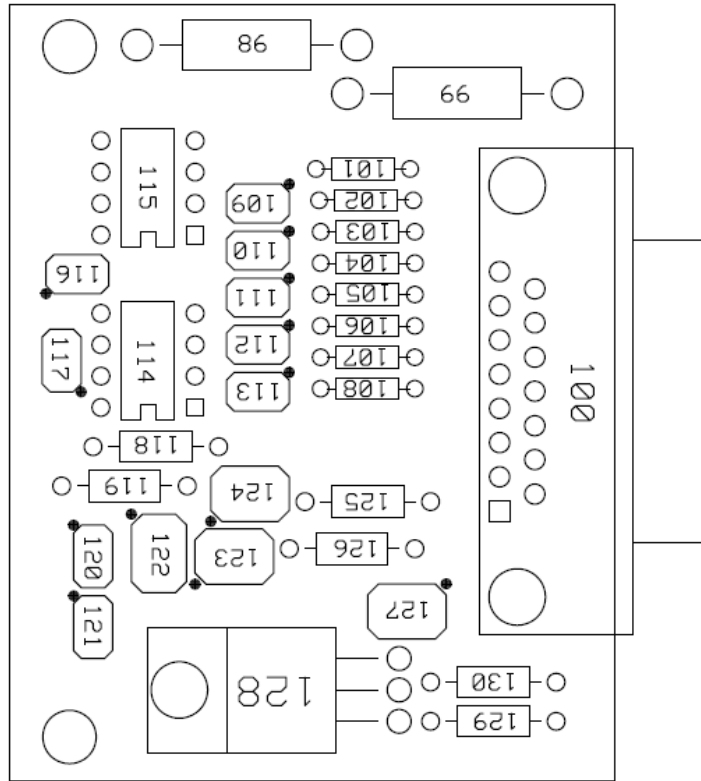

PARTS LOCATOR (Rev L)

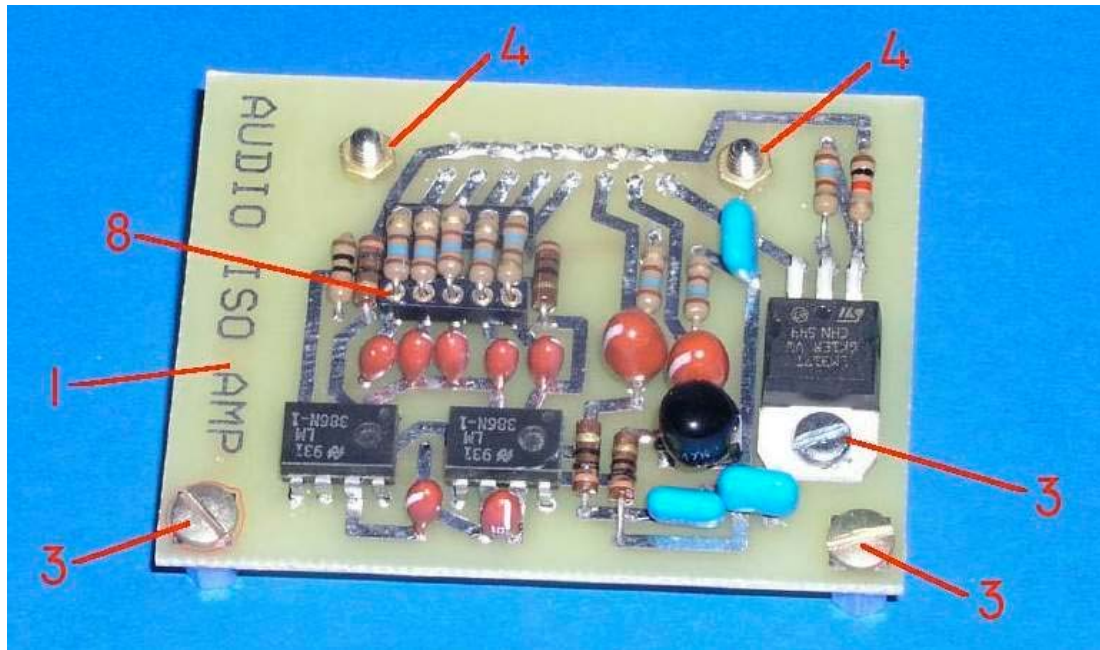

HARDWARE LOCATOR

REV -L- 09/08/09

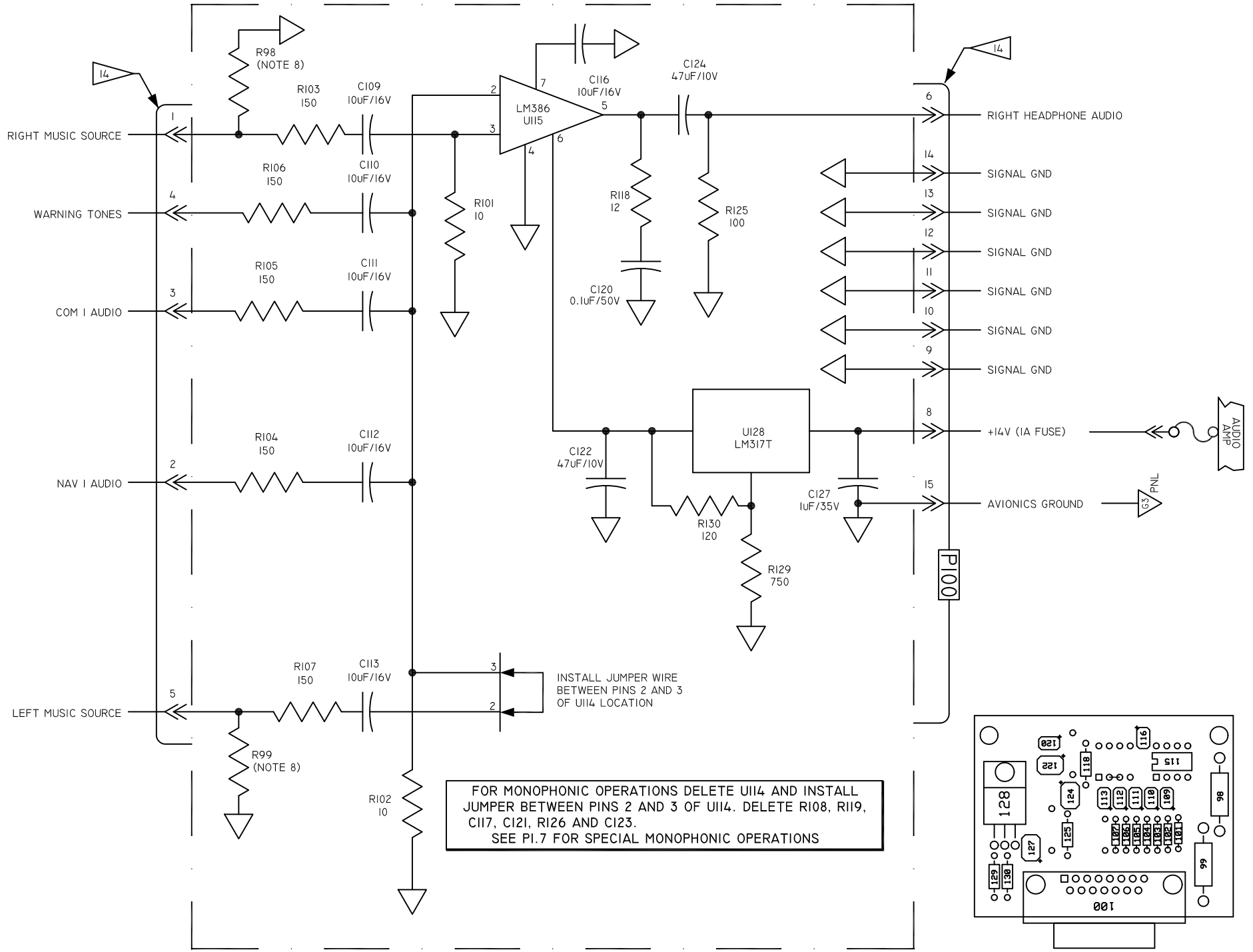

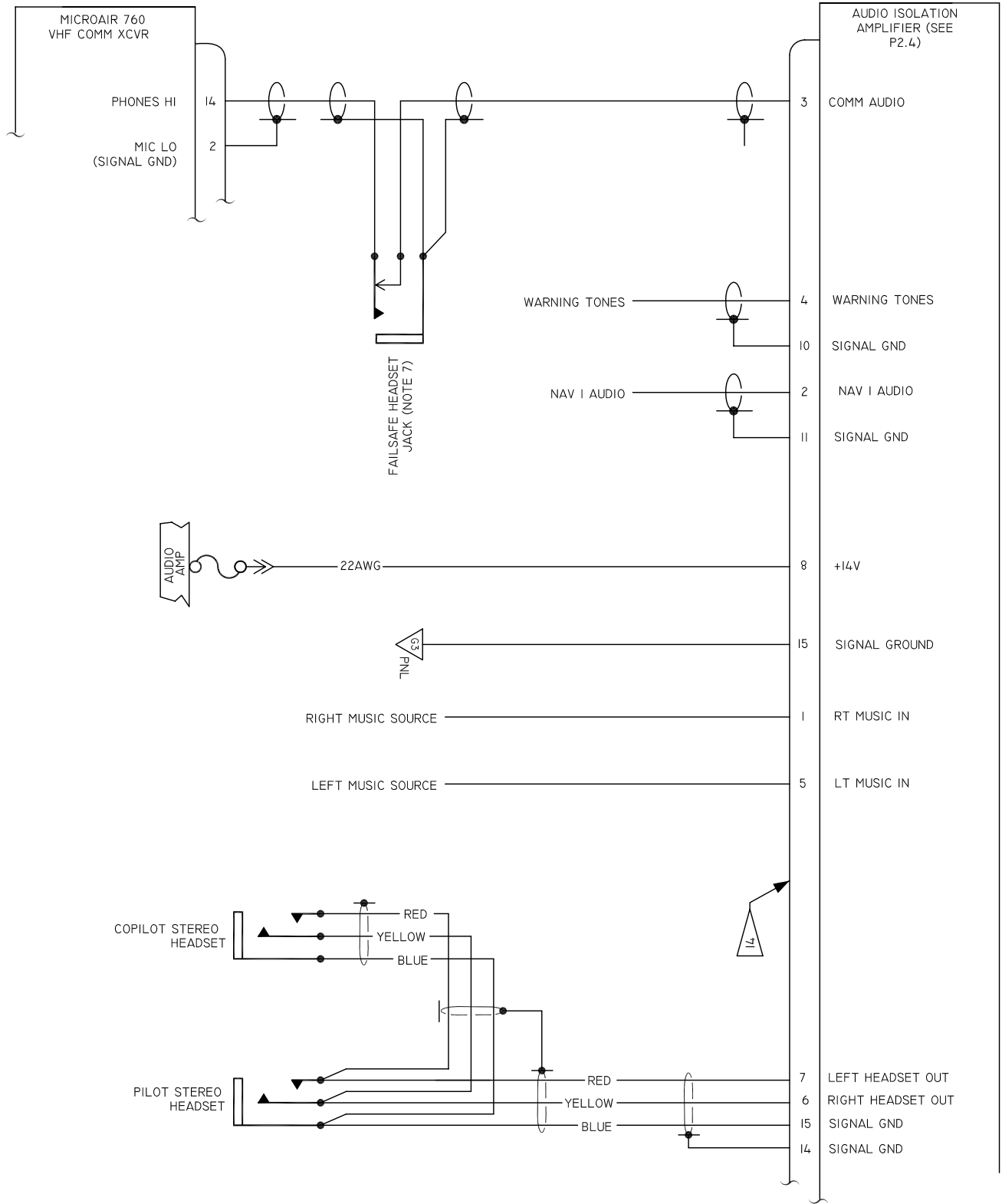

REV -J- 09/06/06

TITLE	PAGE
TYPICAL STEREO AUDIO	1.9

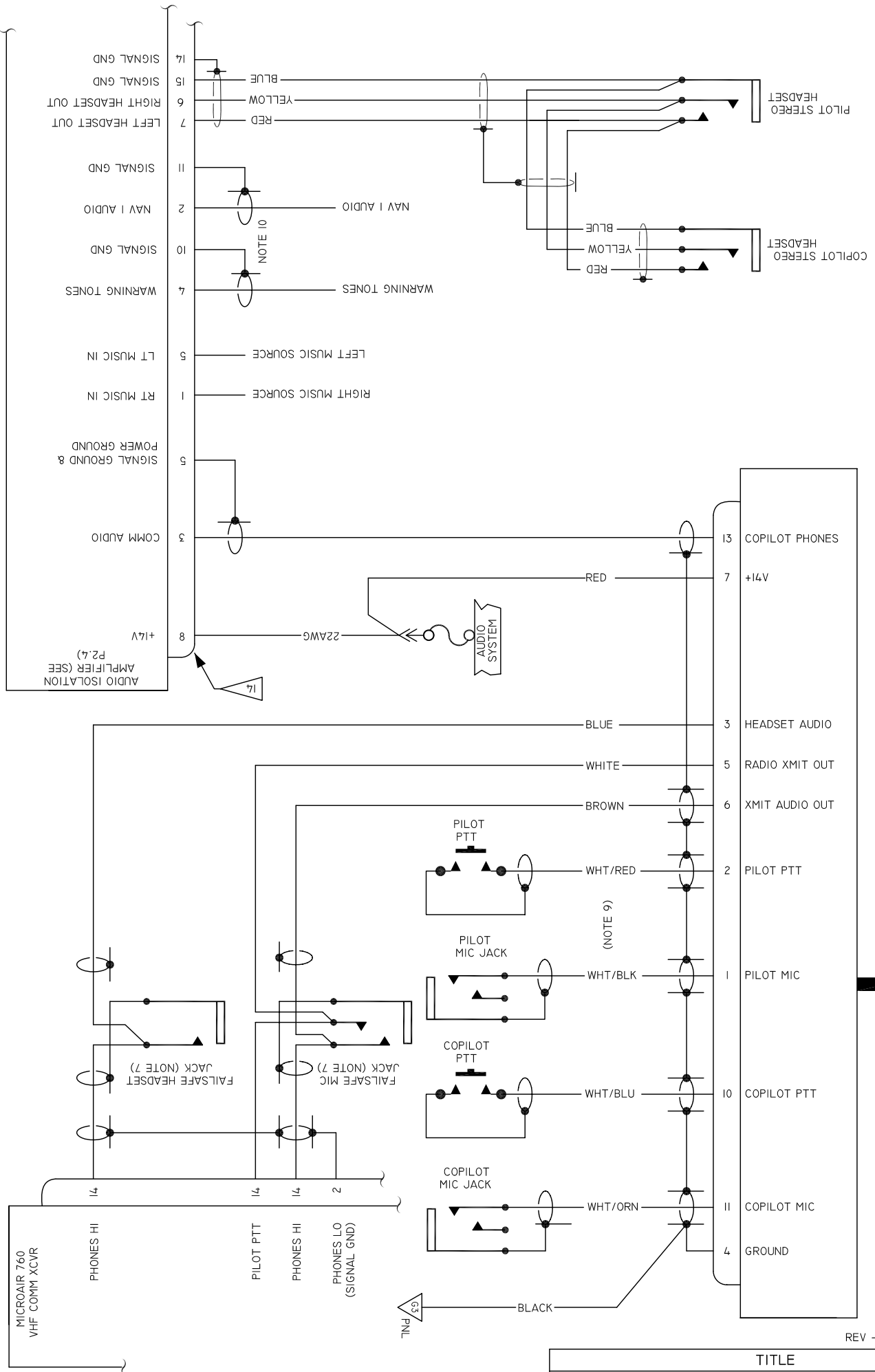

SIGTRONICS SPA400 INTERCOM

REV -J- 09/06/06

TITLE	PAGE
SPA400 (MONO) + STEREO ISO AMP	1.10

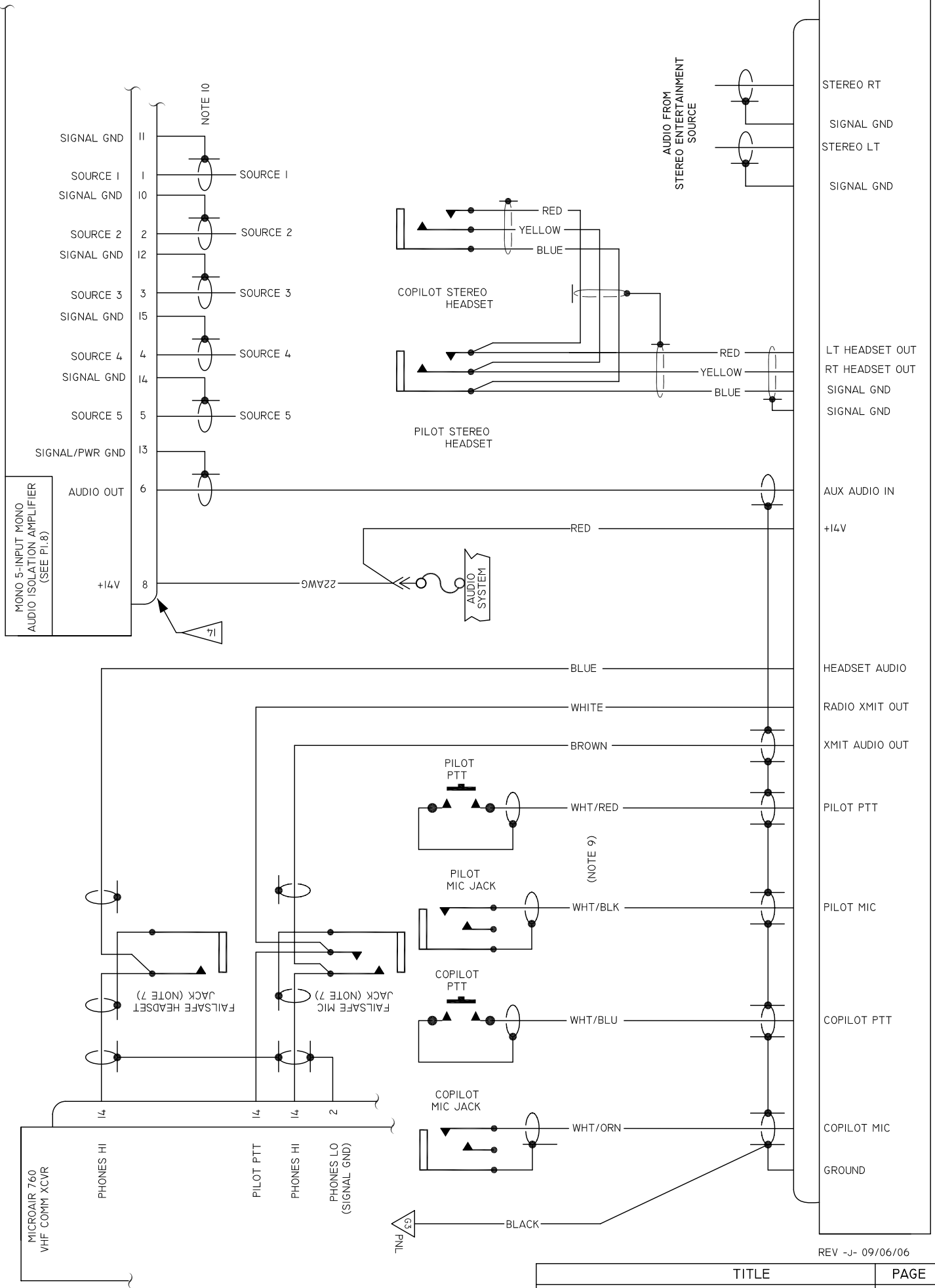

REV -J- 09/06/06

TITLE	PAGE
STEREO ICOM + MONO ISO AMP	I.II

AMPLIFICATION OF NOTE 6:

REVISION H DELETES A PREVIOUSLY CITED INTEGRATED CIRCUIT SOCKET AND SOLDER-IN HEADER AND SUBSTITUTES A MACHINED PIN IC SOCKET AS SHOWN BELOW

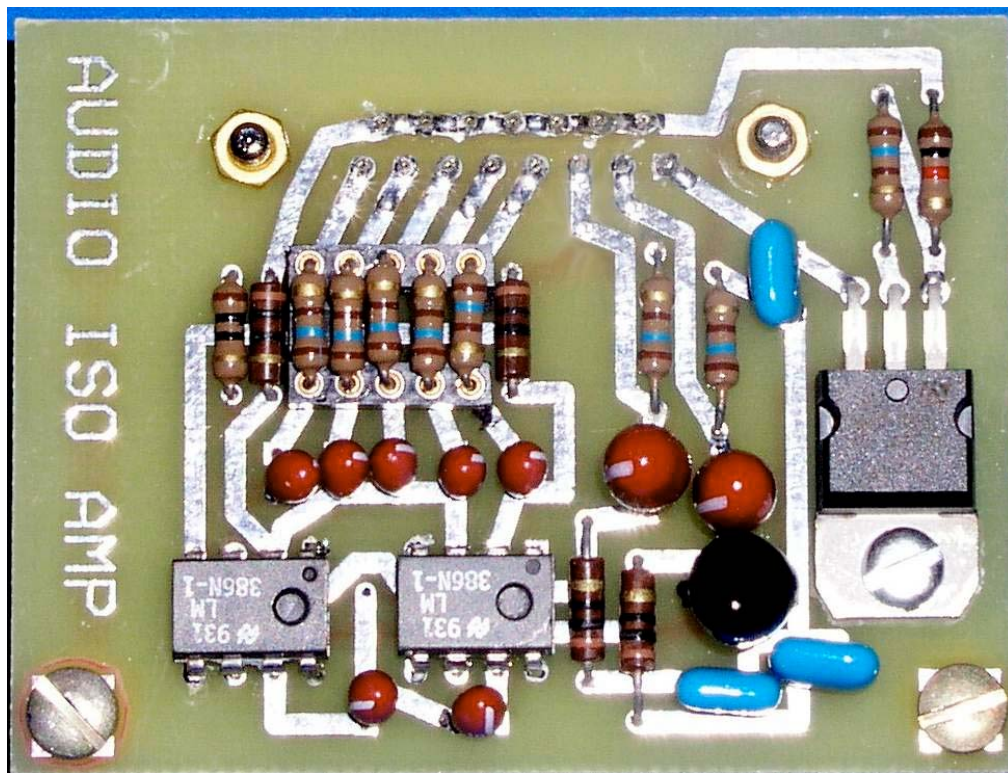

RAW MATERIAL FOR THE 10 PIN (5-RESISTOR SLOT) SOCKET SHOWN IS A 14-PIN SOCKET THAT HAS BEEN SHORTENED ON A BELT SANDER.