

- NOTES:
1. USE GROMMETS TO PROTECT WIRES WHERE THEY PENETRATE THE ENCLOSURE.
 2. USE WIRE CLAMPS TO STRAIN RELIEVE WIRE CONNECTIONS TO INTERNAL CIRCUITRY.
 3. 2XX-XXX NUMBERS ARE RADIO SHACK, OTHERWISE SEE DIGI-KEY CATALOG.
 4. MOUNT LM340K12 REGULATOR ON DIGI-KEY HS142 HEATSINK.
 5. USE RADIO SHACK 276-1371 INSULATOR KIT AND 276-1372 HEAT SINK GREASE TO INSTALL LM340K.
 6. DIGIKEY CATALOGS ARE FREE FOR ASKING, CALL 1-800-344-4539.

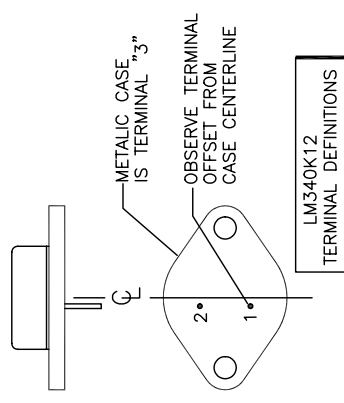

276-1778
LM317T REGULATOR
(NO HEAT SINK REQUIRED FOR
SOLAR POWERED MAINTAINER
OPERATING AT 100 mA OR LESS)

270-364
FUSEHOLDER
270-1278
5 AMP FUSE

272-1055
1.0uF/50V
(2 PLACES)

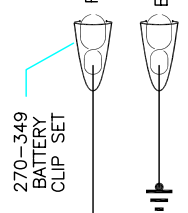
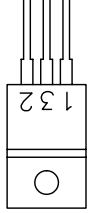
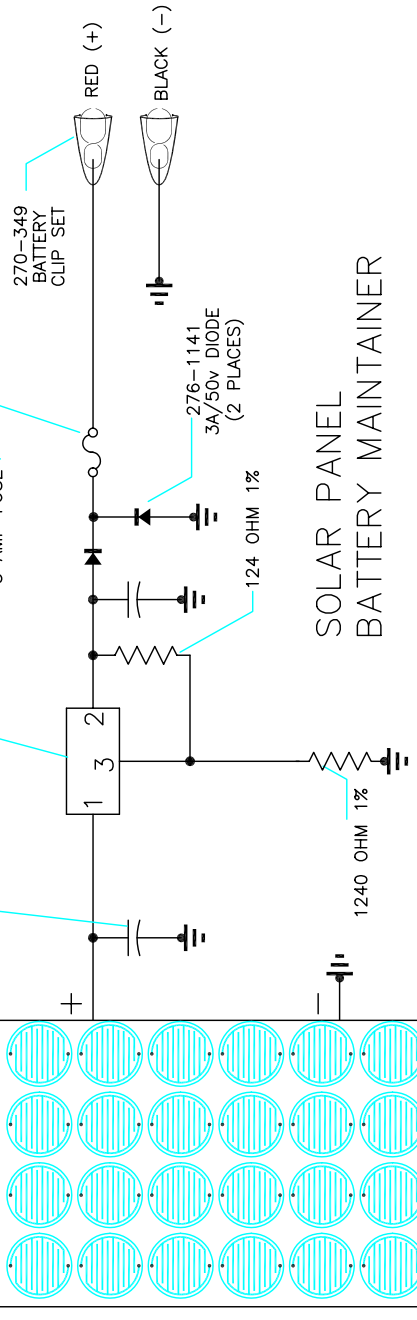

270-364
FUSEHOLDER
270-1273
1 AMP FUSE

276-1141
3A/50V DIODE (3 PLACES)

270-364
FUSEHOLDER
270-1278
5 AMP FUSE

LM317K
REGULATOR
(ON HEATSINK)

276-1171
DIODE BRIDGE

273-1511
TRANSFORMER

272-1022
4700uF/35v

271-153
1K/1W

1240
1%

124 OHMS 1%

272-1055
1.0uF/50V

115 VAC BATTERY
MAINTAINER

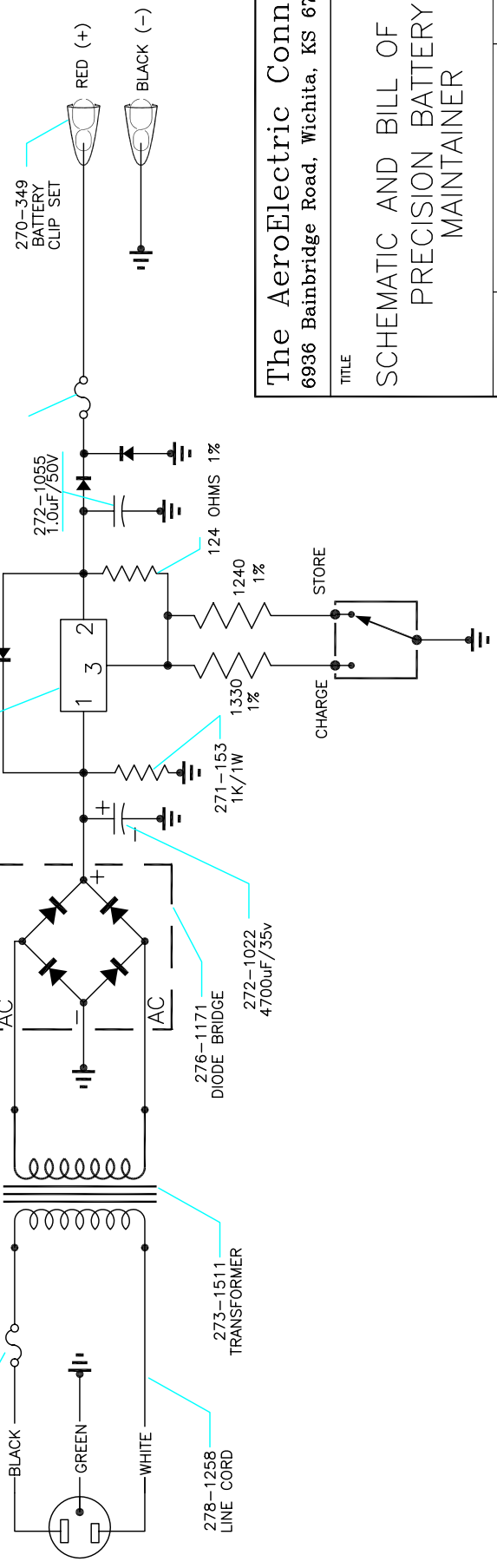

The AeroElectric Connection
6936 Bainbridge Road, Wichita, KS 67226-1008

TITLE
SCHEMATIC AND BILL OF MATL'S
PRECISION BATTERY
MAINTAINER

REVISION D DATE 3-30-97 PAGE 1 OF 1

BATTERY UNDER CHARGE
1 TO 10 CELLS OF AA THRU D
NICKLE-CADMIUM

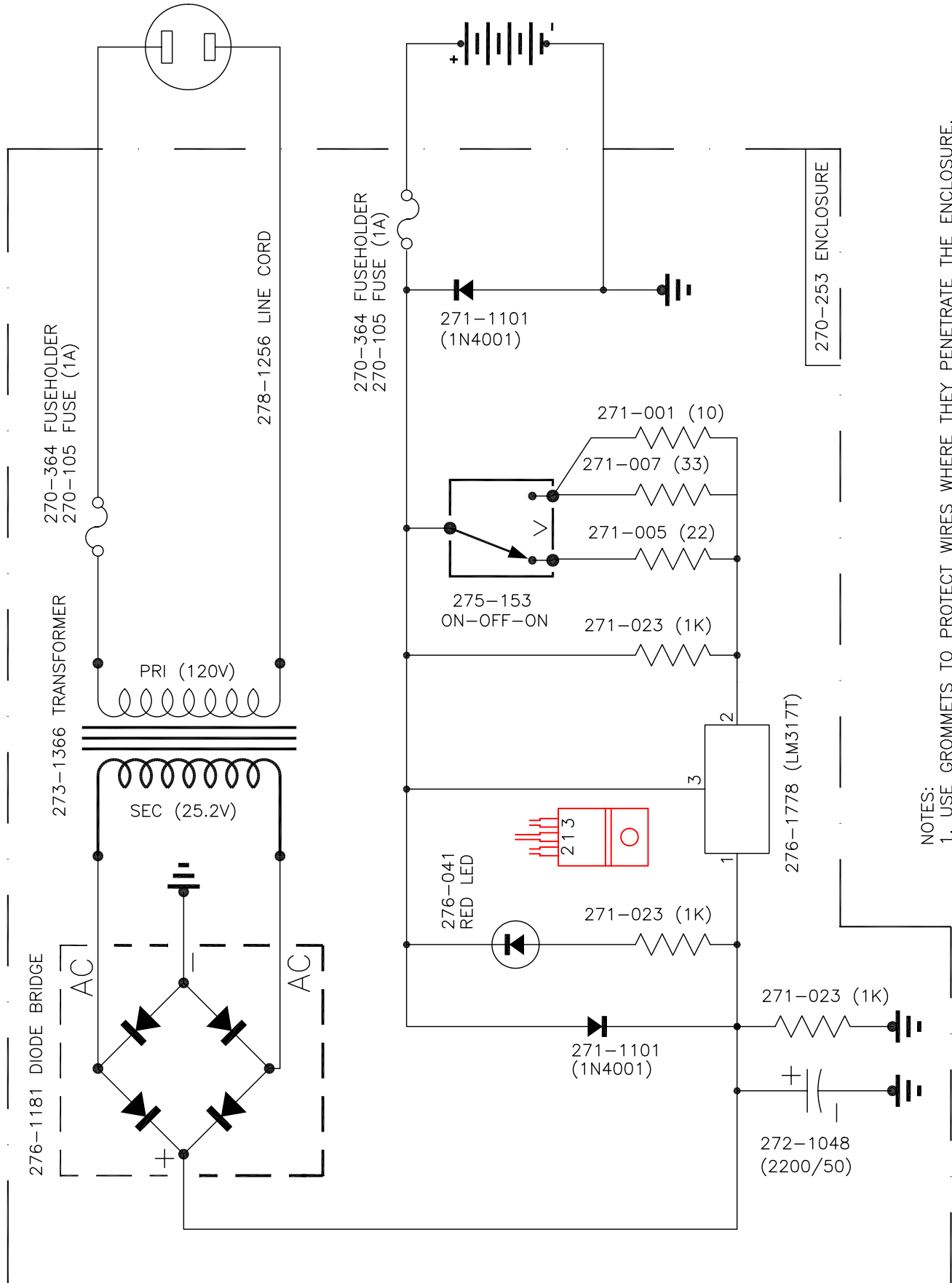

- NOTES:
1. USE GROMMETS TO PROTECT WIRES WHERE THEY PENETRATE THE ENCLOSURE.
 2. USE WIRE CLAMPS TO STRAIN RELIEVE WIRE CONNECTIONS TO INTERNAL CIRCUITRY.
 3. (RS 2XX-XXXX) ARE RADIO SHACK CATALOG NUMBERS.
 4. MOUNT LM317T (RS 276-1778) REGULATOR ON 2" SQUARE PIECE OF ALUMINUM WHICH IS INSULATED

NOTES:

1. THIS CHARGER MAY BE FABRICATED USING TECHNIQUES SIMILAR TO OTHER CHARGERS DESCRIBED IN THIS DATA PACKAGE.
2. THE AEC9015-1 REGULATOR MAY BE PERMANENTLY MOUNTED IN THE AIRCRAFT. IN THIS CASE, DELETE RED AND BLACK CLIPS, ATTACH LEADS DIRECTLY TO BATTERY (+) AND AIRCRAFT GROUND. LOCATE FUSEHOLDER AS CLOSE AS POSSIBLE TO BATTERY. PROVIDE CONNECTION FOR ROOF MOUNTED SOLAR PANEL IN SOME LOCATION THAT ALLOWS EASY ACCESS AND ROUTING OF WIRES TO THE CHARGING REGULATOR.

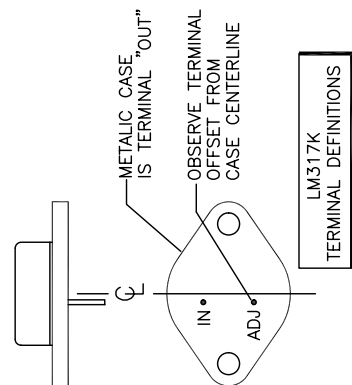
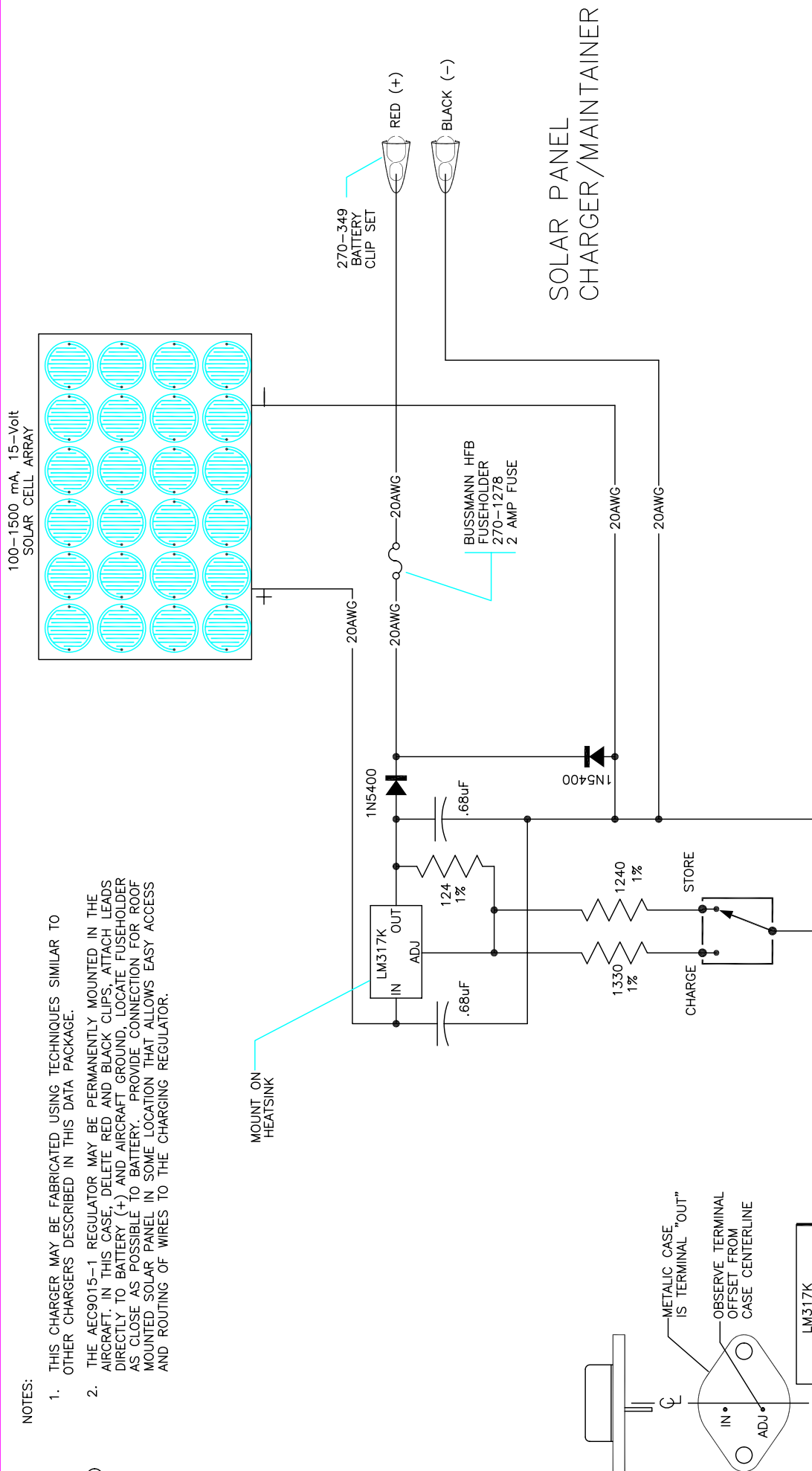

This charger is designed to handle the extra stress of recharging a "DEAD" but otherwise okay battery. For maintaining a battery in full-charge readiness, set voltage for 13.8 volts (switch CHRG). For long term storage of any lead-acid battery, set voltage for 13.0 volts (switch STORE).



BATTERY TENDER® JUNIOR PRODUCT INFORMATION

Battery Tender® Junior: Models:12V0.75A, 6V0.75A



The Battery Tender® Junior

6 Volt, 0.750 Amp
12 Volt, 0.750 Amp

GENERAL

DESCRIPTION: The Battery Tender® Jr. battery charger is a wall mounted, linear power converter that has a true DC output at a

maximum power level of approximately 9 or 5.5 watts respectively for the 12V and 6V models. Both models have a maximum output charging current of 0.75 amps.

OUTPUT CABLE CONNECTIONS: The battery charger DC output cable has a molded, quick disconnect plug. The ring terminal, alligator clip, and cigarette adapter output cable accessories all contain the mating plug.

STATUS INDICATOR LIGHTS: The following describes the operation of the status indicator lights:

- **RED** - When the red light is on, the battery charger is in the process of fully charging the battery. In order to properly charge large capacity batteries, the charger may remain in this mode for several hours or even days.
- **GREEN** - When the green light is lit, the battery charger is in the storage mode of charge. In this mode the charger will maintain the battery at full charge.

SPECIAL TROUBLESHOOTING INFORMATION:

- 1) **NEITHER OF THE CHARGER STATUS INDICATOR LIGHTS TURN ON:**
 - a) Disconnect the charger AC power plug from the AC outlet and recheck that the battery charger alligator clips or ring terminals are connected to the correct polarity battery terminals and that they are making a clean, tight connection.
 - b) Check to make sure that the AC outlet is supplying power by plugging in another appliance like a lamp, or check the outlet voltage with a voltmeter.
- 2) **THE STORAGE/FLOAT MAINTENANCE STATUS INDICATOR LIGHT (GREEN LIGHT) GOES ON IMMEDIATELY WHEN CHARGING A BATTERY KNOWN TO BE DISCHARGED:**



BATTERY TENDER® JUNIOR PRODUCT INFORMATION

- a) The battery may be defective. Take the battery to the dealer to be tested.
- b) The electrical connections between the charger and the battery may not be completely secured.

3) AFTER THE STORAGE/FLOAT MAINTENANCE STATUS INDICATOR LIGHT (GREEN LIGHT) HAS BEEN ON, THE RED LIGHT COMES ON.

- a) This is NORMAL OPERATION for the Battery Tender® Junior.
- b) There has been a momentary AC power outage that reset the charge cycle.

There is some other load or appliance drawing power from the battery. When the battery voltage drops below 12.0V to 12.5V, the charge cycle resets

Battery Tender Junior Battery Charger 12 V 0.750 Amp Performance Comparison

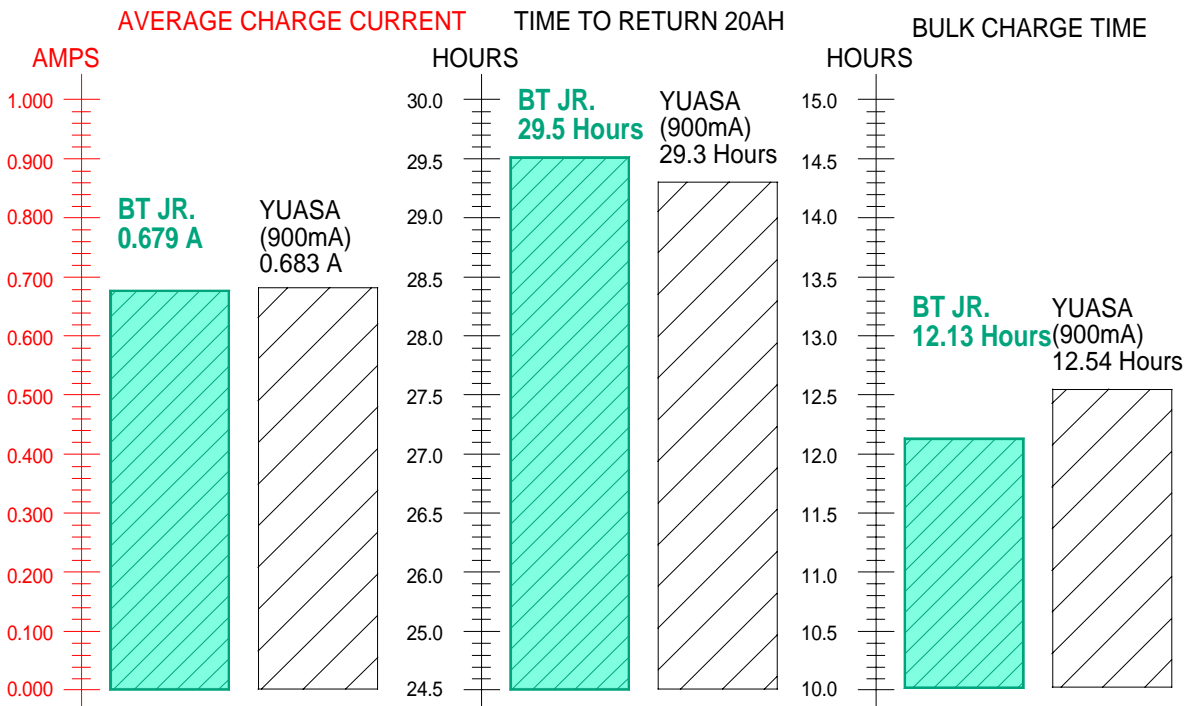

Figure 1 Performance Comparison Chart



BATTERY TENDER® JUNIOR PRODUCT INFORMATION

Battery Tender® Junior (12 & 6 Volt)		
Charger Specification Summary		
Deltran Part Number:	021-0123	021-0127
Nominal Output:		
Voltage:	12 Volts	6 Volts
Current:	0.75 Amps	0.75 Amps
Input Voltage:	115 VAC	
Input Frequency:	60 Hz	
Maximum Input Current:	0.43 Arms	0.23 Arms
Nominal Efficiency:	60%	60%
Nominal Power Factor:	0.78	0.78
Charger Output:		
Maximum Power: (+/- 3%) @ 25 °C	9 Watts	5.5 Watts
Maximum Current: During Bulk Charge	0.75 Amps	0.75 Amps
Absorption Voltage:	14.4 VDC = (2.37 vpc)	7.2 VDC = (2.37 vpc)
Note: Since the Battery Tender® Junior is a 2-step charger; the absorption voltage is the switchover point from bulk charge to float charge.		
Equalization Voltage:	NA	
Float Voltage:	13.2 VDC = (2.2 vpc)	6.6 VDC = (2.2 vpc)
Charge Reset: Battery Voltage Threshold	12 to 12.5 VDC (2 to 2.08 vpc)	6 to 6.2 VDC (2 to 2.07 vpc)
Electrical Isolation:		
Input / Output:	1500 VAC	
Input / Chassis:	1500 VAC	
Output / Chassis:	500 VAC	
Operating Temp:	-20°C to 50°C	
Dimensions:	3.313 in(85 mm)L x 2.313 in(59 mm)W x 1.875 in(48 mm)H	
Weight:	1 lb.	
Carton Size: (Plastic Clam Shell)	7.5 in(191 mm)L x 3.75 in(96 mm)W x 9.25 in(235)H	
Shipping Weight:	2 lbs.	
Enclosure:	94V0 Flame Retardant Plastic	
Special Features:		
Short Circuit Protection:	YES	
Reverse Polarity Protection:	YES	
Spark Proof:	YES	
Temperature Compensation:	NO	
Agency Listings: UL, ETL, CSA, etc.	Designed to meet UL-1236 and CSA 22.2 Contact the office in DeLand, FL for information on agency listings. Phone: 386-736-7900	

Table 1 Specification Sheet: Battery Tender® Junior



Battery Tender® Junior 6V0.750A:

Stage 1) Bulk Charge: Red Light On, Green Light Off, Constant Current = 0.750 Amp, Transition to Stage 2, Absorption Charge when battery voltage reaches 7.2 VDC.

Stage 2) Absorption Charge: Technically, there is no clearly defined Absorption phase because there is no constant voltage period before the float / maintenance phase.

However in the region where the battery voltage increases above 7.0 VDC, the normal minimum absorption voltage for a GEL cell, one could argue that there that there is some absorption activity taking place in terms of the battery electro-chemical reaction to the higher voltage.

Stage 3) There is no Equalization Charge, Go directly to stage 4.

Stage 4) Float Charge: Red Light Off, Green Light On. Float Voltage = 6.6 VDC. If an external load is applied to the battery while the charger is in stage 4, Float Charge, and if the battery voltage drops below a range between 6.0 to 6.25 VDC, then the charge cycle restarts.

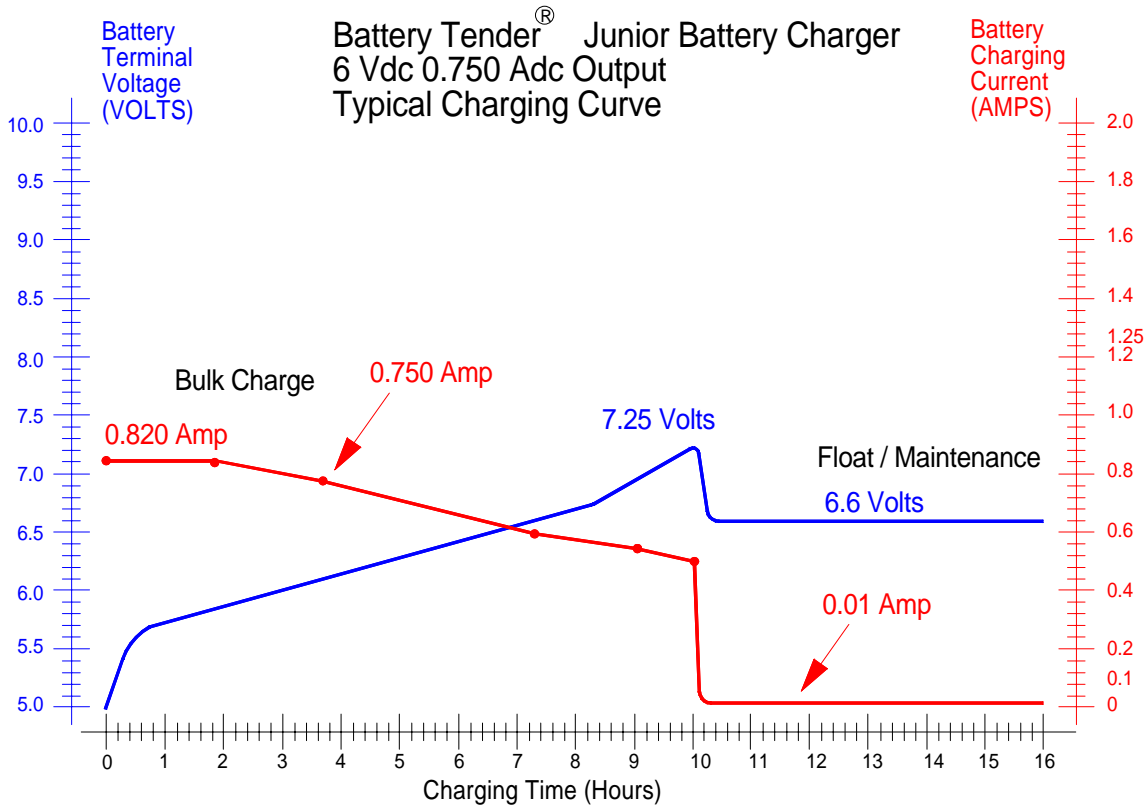

Figure 2 Charging Graph: Battery Tender® Junior 6V0.750A



Battery Tender® Junior 12V0.750A:

Stage 1) Bulk Charge: Red Light On, Green Light Off, Constant Current = 0.750 Amp, Transition to Stage 2, Absorption Charge when battery voltage reaches 14.4 VDC.

Stage 2) Absorption Charge: Technically, there is no clearly defined Absorption phase because there is no constant voltage period before the float / maintenance phase.

However in the region where the battery voltage increases above 14.1 VDC, the normal minimum absorption voltage for a GEL cell, one could argue that there that there is some absorption activity taking place in terms of the battery electro-chemical reaction to the higher voltage.

Stage 3) There is no Equalization Charge, Go directly to stage 4.

Stage 4) Float Charge: Red Light Off, Green Light On. Float Voltage = 13.2 VDC. If an external load is applied to the battery while the charger is in stage 4, Float Charge, and if the battery voltage drops below a range between 12.0 to 12.5 VDC, then the charge cycle restarts.

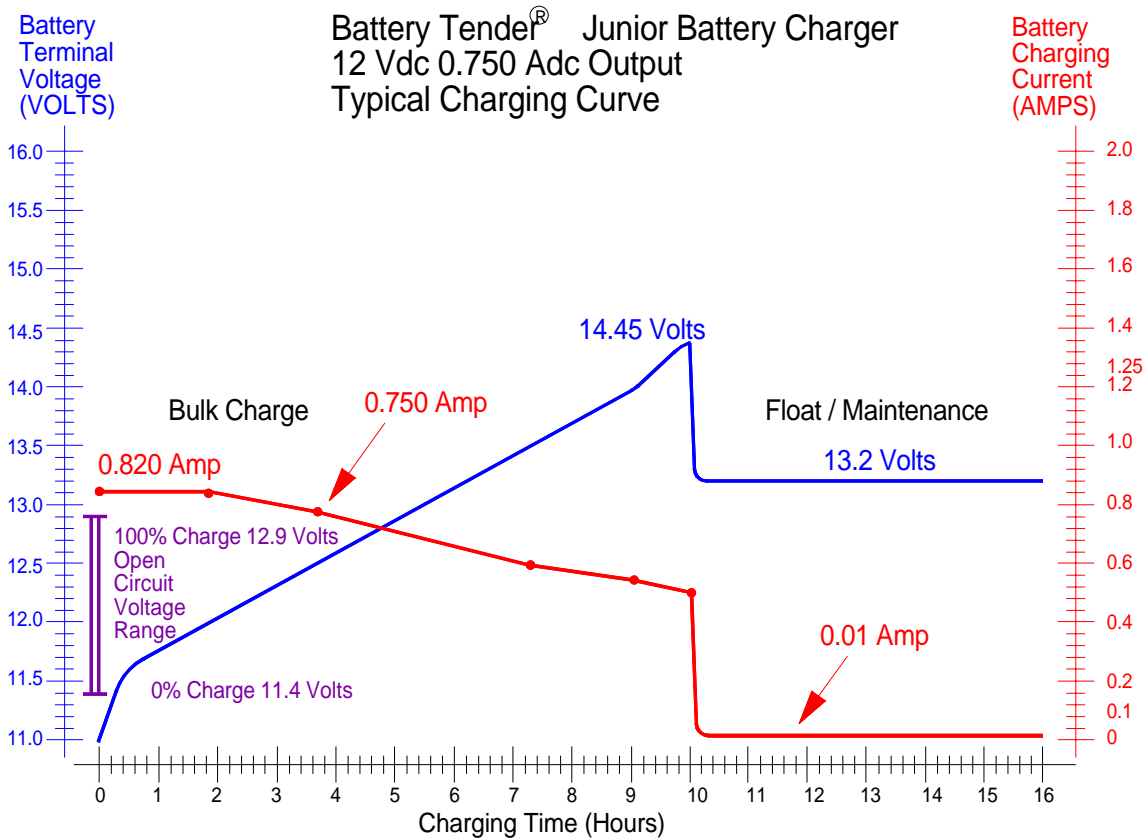

Figure 3 Charging Graph: Battery Tender® Junior 12V0.750A



MODEL WM • 1562A

Schumacher®

BATTERY COMPANION™

FULLY AUTOMATIC BATTERY CHARGER/ MAINTAINER

WITH FLOAT-MODE MONITORING

For Motorcycle, Lawn Tractor, ATV, RV,
Boat, Antique and Classic Car Batteries

 **VERSATILE QUICK-
DISCONNECT HARNESS**



6 VOLT **12** VOLT

1.5 amp
SLOW
CHARGE

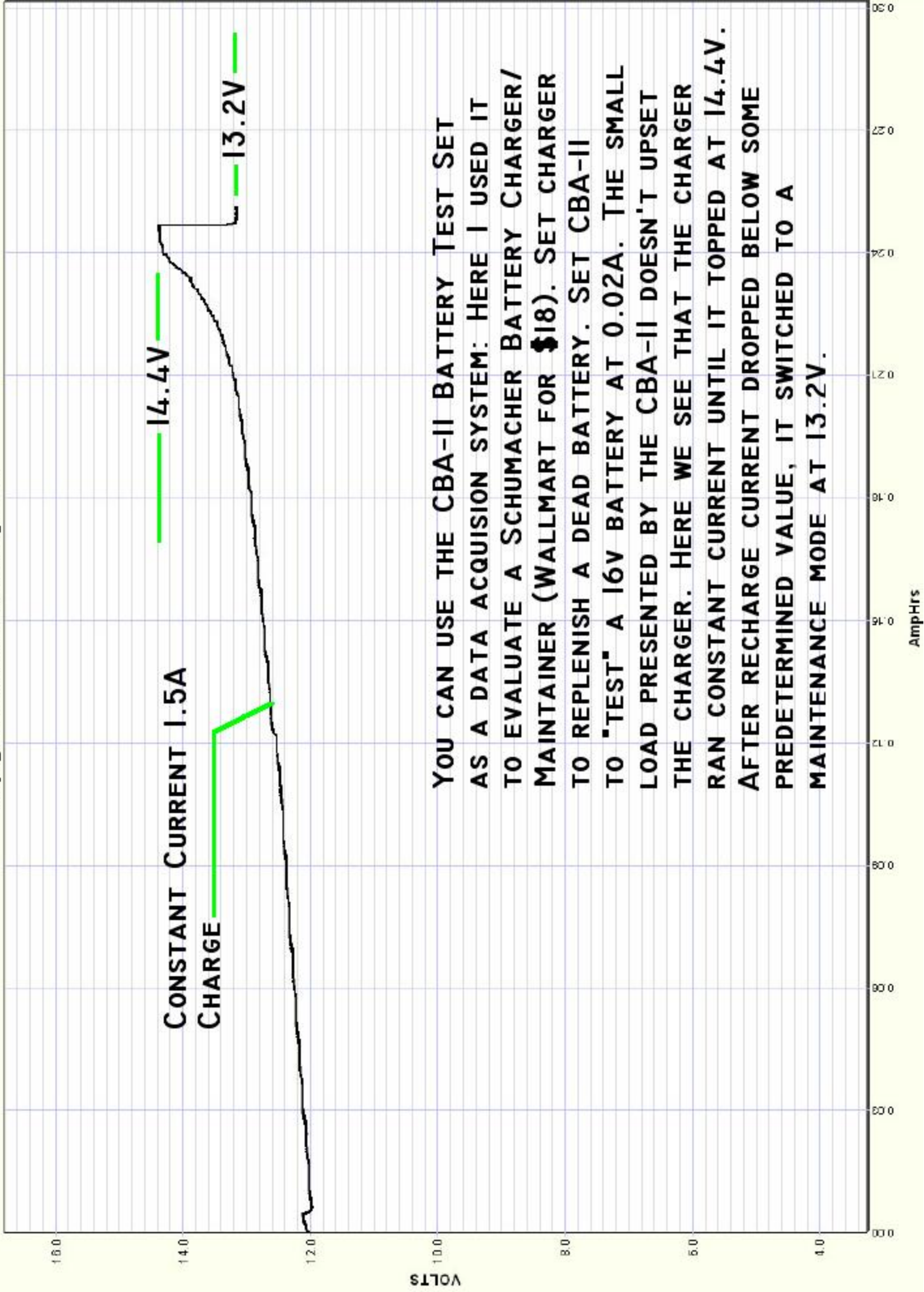

YOU CAN USE THE CBA-II BATTERY TEST SET AS A DATA ACQUISITION SYSTEM: HERE I USED IT TO EVALUATE A SCHUMACHER BATTERY CHARGER/ MAINTAINER (WALLMART FOR \$18). SET CHARGER TO REPLENISH A DEAD BATTERY. SET CBA-II TO "TEST" A 16V BATTERY AT 0.02A. THE SMALL LOAD PRESENTED BY THE CBA-II DOESN'T UPSET THE CHARGER. HERE WE SEE THAT THE CHARGER RAN CONSTANT CURRENT UNTIL IT TOPPED AT 14.4V. AFTER RECHARGE CURRENT DROPPED BELOW SOME PREDETERMINED VALUE, IT SWITCHED TO A MAINTENANCE MODE AT 13.2V.